



WATERFLUX 3070 Technical Datasheet

Battery powered electromagnetic water meter

- Battery driven with very low power consumption for remote locations
- Easy installation without straight inlet or outlet lengths
- Integrated pressure and temperature sensor



1	Product features	4
1.1	The power of independence	4
1.2	Options	6
1.3	Measuring principle.....	9
2	Technical data	10
2.1	Technical data.....	10
2.1.1	Integrated P&T sensor (optionally)	16
2.2	Legal metrology.....	17
2.2.1	OIML R49	17
2.2.2	MID Annex MI-001	20
2.3	Measurement accuracy	23
2.3.1	WATERFLUX 3070 without straight inlet and outlet sections	24
2.4	Dimensions and weights	25
2.5	Pressure loss.....	27
2.6	Battery lifetime	28
3	Installation	29
3.1	General notes on installation	29
3.2	Intended use	29
3.3	Pre-installation requirements	29
3.4	General requirements	30
3.4.1	Vibration	30
3.4.2	Magnetic field.....	30
3.5	Installation conditions	31
3.5.1	Inlet and outlet	31
3.5.2	T-section	31
3.5.3	Bends	32
3.5.4	Open feed or discharge.....	32
3.5.5	Pump	33
3.5.6	Control valve	33
3.5.7	Air venting and vacuum forces	33
3.5.8	Mounting position and flange deviation.....	34
3.5.9	IP68.....	35
3.6	Mounting	36
3.6.1	Torques and pressures.....	36
3.7	Mounting of the signal converter	39
3.7.1	IP67 housing, remote version	39
3.7.2	IP68 housing, compact version.....	39
4	Electrical connections	40
4.1	Safety instructions.....	40
4.2	Grounding	40
4.3	Connection of the signal cable WSC (25 meter and shorter)	41
4.3.1	IP 67 housing (field version).....	41
4.3.2	Requirements for signal cables provided by the customer	43

4.3.3 Signal cable A (type DS 300), construction	44
4.3.4 Preparing signal cable A (25 meter and longer) and connection to measuring sensor	45
4.4 Connection of the output cable	47
4.4.1 IP67 housing (compact and field version).....	47
4.4.2 IP68 housing (compact version).....	48
5 Notes	49

1.1 The power of independence

The IFC 070 is a battery powered electromagnetic signal converter designed for use in combination with the WATERFLUX 3000 sensor. It is ideal for remote locations in the water industry where no power connection is available and provides certainty in case of power failure.

The strengths of the WATERFLUX 3070 lies in its unique flow sensor construction with a rectangular and reduced cross section and its efficient coil construction. The coils provide a stronger and more homogeneous magnetic field, leading to an improved signal to noise ratio. The measurement is therefore independent of the flow profile and measurements are very stable. This results in a very good low flow performance.

Because of the unique WATERFLUX flow sensor design, whereby the mean flow velocity and flow profile are optimised within the rectangular and reduced cross section, the additional uncertainty for upstream disturbances is drastically reduced. The water meter can be installed directly behind an elbow or reducer in the pipe without straight inlet or outlet lengths. A substantial reduction of inlet and outlet sections means smaller measurement pits.

Another major benefit of the rectangular sensor construction is the very low power consumption of the signal converter. It has a long battery lifetime up to 15 years with two internal batteries and 20 years with an external battery pack.

Optional, an in line measurement of the pressure and temperature at the same location as the flow measurement is available by adding a pressure and temperature sensor in the WATERFLUX flowmeter. The pressure and temperature values can be read on the display of the IFC070 converter. In addition, it is possible to have an alarm on the status output when pressure and/or temperature limits are exceeded.

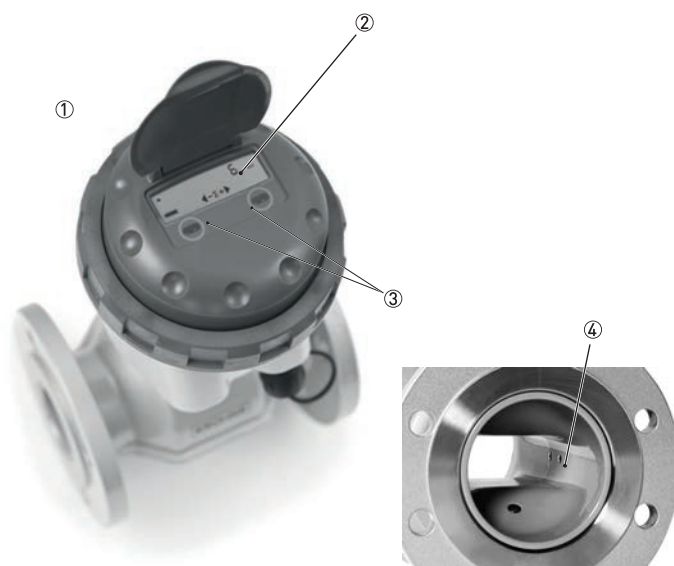

1. Battery powered signal converter
2. LCD Display
3. Two optical keys to operate the converter without opening the housing
4. Integrated pressure and temperature sensor

Highlights

- Stand alone water meter with battery lifetime up to 15 years
- Unique rectangular sensor construction results in good low flow performance and a large turn down ratio
- Large measuring range. High accuracy at peak flows during the day and at low flows during the night
- Flow, pressure and temperature measurement of water, with just one instrument
- Simultaneous flow and pressure measurement for pressure monitoring and leakage control in district zones
- Compliant with requirements for custody transfer (MID MI-001, OIML R49, ISO 4060, EN 14154)
- Standard in-house wet calibration
- Optional verification to MID Annex MI-001 for water meters (Module B and D)
- No inlet or outlet sections required behind elbows or reducers (MID / OIML R49 certified)
- Bi-directional flow metering
- Suitable for subsoil installation and constant flooding (IP68)
- Special coating for subsurface installation
- No need for measurement chambers
- Rilsan® polymer coating
- Drinking water approvals including ACS, DVGW, NSF, TZW and WRAS
- Reference electrode. No grounding rings needed
- Long term reliability and maintenance free.
No moving parts, no wear and no obstruction in the flow
- Optional KGA 42 external data logger and GSM module for remote data transfer

Industries

- Water abstraction
- Distribution networks
- District metering
- Revenue metering
- Irrigation
- Dewatering

Applications

- Measurement of potable water, raw water and irrigation water
- Checking of pumps and water wells
- Monitoring of distribution networks
- Pipeline leak detection
- Water consumption and billing

1.2 Options



Remote or compact version

The WATERFLUX 3070 is available in a compact or a remote (field) version. The remote version of the signal converter can be installed on a wall or on a pipe. The functionality of the compact and the remote version is identical.



Internal and external battery pack

The WATERFLUX 3070 can be operated using 1 or 2 lithium mono cell batteries or an external battery pack. The meter reading is saved internally, which ensures that there is no loss of data when changing the batteries. The signal converter has a very low power consumption because of its rectangular sensor construction. With two internal batteries it has a battery lifetime up to 15 years.

**IP68 (NEMA 6P) version for submersion**

The IFC 070 compact signal converter is available in an aluminium and in a polycarbonate housing.

The signal converter in a polycarbonate housing is suitable for submersion in flooded measurement chambers and is protected to IP68 / NEMA 6P. The output cable has plug and play IP68 rated connectors.

**Maintenance free and buriable**

The flow sensor (IP68) is suitable for submersion in flooded measurement chambers. With its robust construction it can also be buried underground. This can be a major cost saving as it eliminates the need for a measurement chamber. To protect the flow sensor a special coating can be ordered as an option. The remote version has an IP68 stainless steel connection box.



Pressure and temperature sensor

As an option it is possible to integrate a pressure and temperature sensor into the WATERFLUX 3000 sensor. Simultaneous flow and pressure measurement can be used for pressure monitoring, leakage control and district zones.

Temperature measurements can be used when potable water has reached a critical value (should not exceed a certain threshold) . The pressure and temperature values can be read on the display of the IFC 070 converter. An alarm can be generated on the status outputs when critical limits for pressure and or temperature are exceeded.

The pressure and temperature sensor is available for diameter DN50 to DN200 of the compact WATERFLUX 3070 (not available for custody transfer applications).



KGA 42 data logger and GSM module for remote reading

The KGA 42 data logger and GSM module offers an efficient solution for remote reading of water meters and the transmission of data via wireless communication. The KGA 42 sends out SMS/GPRS reports on a daily basis or direct SMS/GPRS alerts to maintenance personnel. The module is easy to install, waterproof (IP68), has a built-in dedicated antenna and operates on batteries.

It is ideal for water meters at remote locations in the drinking water distribution networks or sites difficult to reach such as metering manholes below the ground

1.3 Measuring principle

An electrically conductive fluid flows inside an electrically insulated pipe through a magnetic field. This magnetic field is generated by a current, flowing through a pair of field coils. Inside of the fluid, a voltage U is generated:

$$U = v * k * B * D$$

in which:

v = mean flow velocity

k = factor correcting for geometry

B = magnetic field strength

D = inner diameter of flow meter

The signal voltage U is picked off by electrodes and is proportional to the mean flow velocity v and thus the flow rate q . A signal converter is used to amplify the signal voltage, filter it and convert it into signals for totalising, recording and output processing.

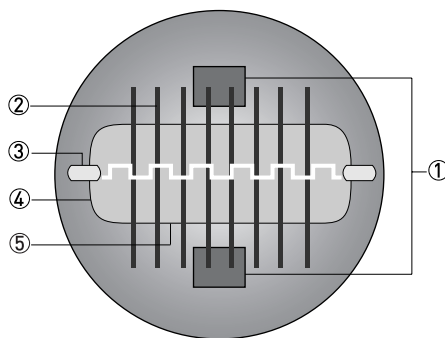

Figure 1-1: Measuring principle

- ① Field coils
- ② Magnetic field
- ③ Electrodes
- ④ Induced voltage (proportional to flow velocity)
- ⑤ Rectangular cross section

Rectangular cross section

The minimal height of the measuring tube decreases the distance between the field coils (4), resulting in a stronger and more homogeneous magnetic field (3). In addition, the mean flow velocity v increases due to the rectangular and reduced cross section. The large electrode spacing (D) and the increased flow velocity results in a higher magnetic signal voltage, also in the presence of a low flow rate.

2.1 Technical data

- The following data is provided for general applications. If you require data that is more relevant to your specific application, please contact us or your local sales office.
- Additional information (certificates, special tools, software,...) and complete product documentation can be downloaded free of charge from the website (Downloadcenter).

Measuring system

Measuring principle	Faraday's law of induction
Application range	Electrically conductive fluids
Measured value	
Primary measured value	Flow velocity
Secondary measured value	Volume flow
Optional measured value	Pressure and temperature

Design

Features	Unique rectangular flow tube design providing improved flow profile and signal to noise ratio resulting in highest accuracy, low energy consumption and large turndown ratio
	Rilsan® polymer coated flow tube approved for drinking water
	No internal or moving parts
	Built-in reference electrode
	Optional; built-in P&T sensor (restricted to DN50...200), Integrated P&T sensor (optionally) refer to <i>Integrated P&T sensor (optionally)</i> on page 16
	Self providing energy by batteries for up to 15 years
Modular construction	The measurement system consists of a flow sensor and a signal converter. It is available as compact and as separate version.
Compact version	With IFC 070 converter: WATERFLUX 3070 C
Remote version	In field (F) version with IFC 070 converter: WATERFLUX 3070 F
	Cable length up to 25 m / 70 ft, other lengths on request
Nominal diameter	DN25...600 / 1...24", Rectangular bore
Display and user interface	
Display	LCD display, 8 digits
Operation	2 optical keys to navigate through the menu of the signal converter without opening the housing.
Display information	Standard:
	Sum counter (default), forward counter, reverse counter or flow rate
	Flow direction (forward or reverse), counter settings
	Measured value
	Measuring unit
	Battery lifetime indicator
	Optional:
Operating pressure, operating temperature, empty pipe, self test, display test, test mode, diameter, meter constant, software version, AMR mode, warning sign, multiplier	
Remote reading	Optional: KGA 42 external data logger / GSM module

Measurements

Measuring units	Volume
	Default setting: m ³
	Selectable: litre, gallon, imperial gallons, cubic feet, acre inch, acre feet
	Flow rate
	Default setting: m ³ / hr
	Selectable: litre/sec, gallon/min, imperial gallon/min, cubic feet/hour, acre inch/day, acre feet/day
Measurement interval	Default setting: 15s
	Selectable: 1s, 5s, 10s, 15s, 20s
Empty pipe detection	Optional: display shows - EP - in case of empty pipe detection
Low flow cut off	Measurements below this value are neglected
	Default setting: 10 mm/s
	Selectable: 0 mm/s, 5 mm/s, 10 mm/s

Measuring accuracy

Reference conditions	Medium: water
	Temperature: +10...30°C / +50...86°F
	Operating pressure: 1 bar / 14,5 psi
	Inlet section: 3 DN / Outlet section: 1 DN
	Electrical conductivity: > 300 µS/cm
Maximum measuring error	DN25...300; down to 0.2% of the measured value ± 1 mm/s DN350...600; down to 0.4% of the measured value ± 1 mm/s
	The maximum measuring error depends on the installation conditions.
	For detailed information refer to <i>Measurement accuracy</i> on page 23.
Repeatability	DN 25...300; ±0.1% (v >0.5 m/s / 1.5 ft/s) DN350...600; ±0.2% (v >0.5 m/s / 1.5 ft/s)
Calibration / Verification	Standard:
	2 Point calibration by a direct volume comparison.
	Optional: for DN25...600
	Verification to Measurement Instrument Directive (MID), Annex MI-001. Standard: Verification at Ratio (Q3/Q1) = 80 Optional: Verification at Ratio (Q3/Q1) > 80
MID MI-001 (Directive 2004/22/EC)	EC-Type examination certificate to MID Annex MI-001
	Diameter: DN25...600
	Minimum straight inlet flow: 0 DN
	Minimum straight outlet flow: 0 DN
	Forward and reverse (bi-directional) flow
	Orientation: any
	Ratio (Q3/Q1): up to 400
	Liquid temperature range: +0.1°C / 50°C
	Maximum operating pressure: ≤ DN200: 16 bar, ≥ DN250: 10 bar
	For detailed information refer to <i>Legal metrology</i> on page 17.

OIML R49	Certificate of conformity to OIML R49
	Diameter: DN25...600
	Accuracy: Class 1 and 2
	Minimum straight inlet flow: 0 DN
	Minimum straight outlet flow: 0 DN
	Forward and reverse (bi-directional) flow
	Orientation: any
	Ratio (Q3/Q1): up to 400
	Liquid temperature range: +0.1°C / 50°C
	Maximum operating pressure: ≤ DN200: 16 bar, ≥ DN250: 10 bar
For detailed information refer to <i>Legal metrology</i> on page 17.	

Operating conditions

Temperature	
Process temperature	-5...+70°C / +23...+158°F
Ambient temperature	-40...+65°C / -40...+149°F
	Ambient temperatures below -25°C / -13°F may affect the readability of the display.
	It is recommended to protect the converter from external heat sources such as direct sunlight because high temperatures reduce the life cycle of all electronic components.
Storage temperature	-50...+70°C / -58...+158°F
Measurement range	-12...12 m/s / -40...40 ft/s
Starting flow	From 0 m/s / 0 ft/s onwards
Pressure	
Operating pressure	Up to 16 bar (232 psi) for DN25...300 Up to 10 bar (150 psi) for DN350...600
Vacuum load	0 mbar / 0 psi absolute
Pressure loss	For detailed information refer to <i>Pressure loss</i> on page 27.
Chemical properties	
Physical conditions	Water: drinking water, raw water, irrigation water. For salt water, please contact the factory.
Electrical conductivity	≥ 20 μS/cm

Installation conditions

Installation	Assure that flow sensor is always fully filled.
	For detailed information refer to <i>Installation</i> on page 29.
Flow direction	Forward and reverse
	Arrow on flow sensor indicates forward flow direction.
Inlet run	DN25...300 ≥ 0 DN DN350...600 ≥ 3 DN
	For detailed information refer to <i>Measurement accuracy</i> on page 23.
Outlet run	DN25...300 ≥ 0 DN DN350...600 ≥ 1 DN
	For detailed information refer to <i>Measurement accuracy</i> on page 23.
Dimensions and weights	For detailed information refer to <i>Dimensions and weights</i> on page 25.

Materials

Sensor housing	Sheet steel
Measuring tube	DN25...200: metallic alloy
	DN250...600: stainless steel
Flanges	Steel 1.0460 / 1.0038 (RSt37-2) DN25...DN200; Wetted parts nickel plated
Liner	Rilsan [®]
Protective coating	On exterior of the meter: flanges, housing, signal converter (compact version) and / or connection box (field version)
	Standard: polyurethane coating
	Option: subsoil coating
Measuring electrodes	Standard: stainless steel 1.4301 / AISI 304
	Optional: Hastelloy [®] C
Reference electrode	Standard: stainless steel 1.4301 / AISI 304
	Optional: Hastelloy [®] C
Grounding rings	Grounding rings can be omitted when the reference electrode is used.
Signal converter housing	Standard:
	Aluminium with a polyester topcoat
	Optional:
Connection box	Polycarbonate (IP68)
	Only for remote versions. Stainless steel (IP68)

Process connections

EN 1092-1	Standard:
	DN25...200: PN 16
	DN250...600 : PN 10
	Optional:
	DN250...600: PN16 (DN350...600: 10 bar rated)
ASME	1...12": 150 lb RF (232 psi / 16 bar rated) 14...24": 150 lb (150 psi / 10 bar rated)
JIS	DN25...300 / 1...12": 10 K DN350...600 / 14"...24": 7,5 K
AS 4087	DN25...600 / 1"...24" : Class 16 on request (DN350...600 / 14"...24": 10 bar rated)
AS 2129	DN25...600 / 1"...24": Table D, E on request (DN350...600 / 14"...24": 10 bar rated)
For detailed information on nominal flange pressure and nominal diameter refer to <i>Dimensions and weights</i> on page 25.	
Other connections	
Thread	DN25: G1" thread connection on request
	DN40: G1.5" & G2" thread connection on request
Other	Weld-on, clamp, oval flanges: on request

Electrical connections

Cable connections		
Cable entries	IFC 070 C and F in aluminium housing (IP67)	
	Standard: 2 x M20 x 1.45	
	Optional: 1/2" NPT, PF1/2	
Output cable	IFC 070 C in polycarbonate housing (IP68)	
	Standard: No output connector. Pulse output not available. Note: output connector can not be added afterwards.	
	Optional: Pulse output activated and connection to KGA 42 data logger - GPRS module. Output cable with 2 plug and play - IP68 rated connectors	
Power supply		
Battery	Standard:	
	Internal battery pack: Single D-cell (Lithium, 3.6V, 19 Ah)	
	Optional:	
	Internal battery pack: Dual D-cell (Lithium, 3.6V, 38 Ah) External battery pack: Dual DD-cell (Lithium, 3.6V, 76 Ah), IP68 rated. Cable length is 1.5 m	
Typical lifetime (default settings)	With 1 internal battery;	DN25...200 : up to 8 years DN250...600 : up to 4 years
	With 2 internal batteries;	DN25...200 : up to 15 years DN250...600 : up to 8 years
	With external battery pack;	DN25...200 : up to 20 years DN250...600 : up to 15 years
	For detailed information refer to <i>Battery lifetime</i> on page 28.	
Alarms	Pre-alarm at < 10% of its original capacity	
	Final alarm at < 1% of its original capacity	
Battery replacement	No loss of totalizer data	

Signal cable (remote versions only)	
Type	KROHNE WSC standard cable, double shielded
Length	Standard: 5m
	Optional: 10m, 15m, 20m, 25m.
	Other cable lengths on request
In- and output	
Pulse output	2 Passive pulse outputs (maximum 3 outputs possible; see status output)
	$f \leq 100$ Hz; $I \leq 10$ mA; $U: 2.7...24$ VDC ($P \leq 100$ mW)
	Volume / pulse is programmable
	Phase shift between pulse A and B (forward and reverse) selectable
	Pulse width is selectable: 5 ms (default), 10 ms, 20 ms, 50 ms, 100ms, 200 ms
Status output	2 Passive status outputs (1 status output can be used as a third pulse output)
	$I \leq 10$ mA; $U: 2.7...24$ VDC ($P \leq 100$ mW)
	Function (selectable): pressure limit maximum, pressure limit minimum, temperature limit maximum, temperature limit minimum, self check, battery pre warning, battery final warning, empty pipe
Communication	Optional: KGA 42 external data logger / GSM module
	For detailed information refer to the KGA 42 documentation.

Approvals and certificates

CE	
This device fulfils the statutory requirements of the EC directives. The manufacturer certifies successful testing of the product by applying the CE mark.	
Electromagnetic compatibility	Directive: 2004/108/EC
	Harmonized standard: EN 61326-1: 2013
Pressure Equipment Directive	Not applicable: networks for the supply, distribution and discharge of water and associated equipment are excluded from the scope of this directive.
Other approvals and standards	
Custody transfer (DN25...600) Not valid for integrated temperature and pressure sensor	MID Annex MI-001 type examination certificate
	OIML R49 certificate of conformity
	Conformity with ISO 4064 and EN 14541
	Innerstaatliche Bauartzulassung als Kaeltezaehler (For Germany, Switzerland and Austria).
	NMI M10 Certificate of approval for accuracy class 2.5 (Australia)
	DN40...100; SANS 1529 (South Africa)
Drinking water approvals	ACS, DVGW W270, NSF / ANSI Standard 61, TZW, WRAS
Protection category according to IEC 529 / EN 60529	Compact version (C) in polycarbonate housing: IP68 (NEMA 4X/6P) (Test conditions; 1500 hours, 10 meters below surface)
	Compact version (C) in aluminium housing: IP66/67 (NEMA 4/4X/6)
	Field version (F) in aluminium housing: IP66/67 (NEMA 4/4X/6)
Shock test	IEC 68-2-27
	30 g for 18 ms
Vibration test	IEC 68-2-64
	$f = 20 - 20000$ Hz, rms = 4.5g, t = 30 min.

2.1.1 Integrated P&T sensor (optionally)

Design

Features	Optional integrated pressure and temperature sensor in WATERFLUX 3000 In combination with: IFC 070C - IP67 IFC 070C - IP68 WATERFLUX 3000 sensor DN50...200
----------	---

Measurements

Measuring range	Pressure
	-0.5...16 bar / -7.3...232 psi (relative)
	Temperature
	-5...+70°C / +23...158°F
Measuring units	Pressure
	Default setting: bar
	Selectable: mbar, psi
	Temperature
	Default setting: °C
	Selectable: °F
Measurement interval	Default setting: 15 min.
	Selectable: 1m, 5m, 10m, 15m

Measuring accuracy

Maximum measuring accuracy	Pressure
	± 1% of full scale (0,5 ...16 bar / -7.3...232 psi) mm/s
	Temperature
	± 1,5°C for -5°...+70°C / +23...158°F

Materials

Pressure and temperature sensor	316L
---------------------------------	------

2.2 Legal metrology

2.2.1 OIML R49

The WATERFLUX 3070 has a certificate of conformity with the international recommendation OIML R49. The certificate has been issued by NMI (Dutch board of weight and measures). The OIML R49 recommendation (2006) concerns water meters intended for the metering of cold potable and hot water. The measuring range of the water meter is determined by Q_3 (nominal flow rate) and R (ratio).

The WATERFLUX 3070 meets the requirements for water meters of accuracy class 1 and 2.

- For accuracy class 1, the maximum permissible error for water meters is $\pm 1\%$ for the upper flow rate zone and $\pm 3\%$ for the lower flow rate zones.
- For accuracy class 2, the maximum permissible error for water meters is $\pm 2\%$ for the upper flow rate zone and $\pm 5\%$ for the lower flow rate zones.

According to OIML R49, accuracy class 1 designation shall be applied only to water meters with $Q_3 \geq 100 \text{ m}^3/\text{h}$.

$$Q_1 = Q_3 / R$$

$$Q_2 = Q_1 * 1.6$$

$$Q_3 = Q_1 * R$$

$$Q_4 = Q_3 * 1.25$$

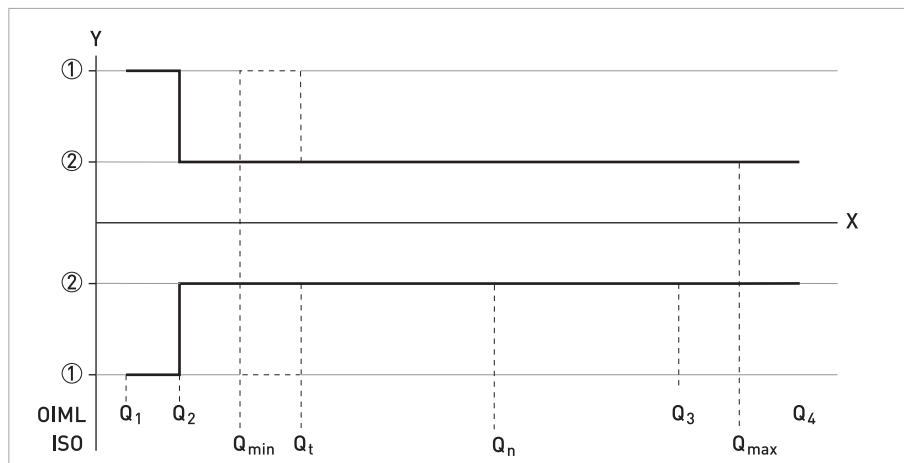

Figure 2-1: ISO flow rates added to figure as comparison towards OIML

X: Flow rate

Y [%]: Maximum measuring error

① $\pm 3\%$ for class 1, $\pm 5\%$ for class 2 devices

② $\pm 1\%$ for class 1, $\pm 2\%$ for class 2 devices

OIML R49 Class 1; certified metrological characteristics

DN	Span (R) Q3 / Q1	Flow rate [m ³ /h]			
		Minimum Q1	Transitional Q2	Permanent Q3	Overload Q4
65	250	0.400	0.64	100	125
80	160	0.625	1.00	100	125
80	250	0.640	1.02	160	200
100	160	1.00	1.60	160	200
100	250	1.00	1.60	250	312.5
125	160	1.5625	2.50	250	312.5
125	250	1.60	2.56	400	500
150	160	2.50	4.00	400	500
150	250	2.52	4.03	630	787.5
200	160	3.9375	6.30	630	787.5
250	160	6.25	10.00	1000	1250
300	160	10.00	16.00	1600	2000
350	50	32.00	51.20	1600	2000
400	50	50.00	80.00	2500	3125
450	50	50.00	80.00	2500	3125
500	50	80.00	128.00	4000	5000
600	40	100.00	160.00	4000	5000

OIML R49 Class 2; certified metrological characteristics

DN	Span (R) Q3/Q1	Flow rate [m ³ /h]			
		Minimum Q1	Transitional Q2	Permanent Q3	Overload Q4
25	400	0.025	0.040	10	12.5
25	400	0.040	0.064	16	20.0
40	400	0.0625	0.100	25	31.3
40	400	0.100	0.160	40	50.0
50	400	0.100	0.160	40	50.0
50	400	0.1575	0.252	63	78.75
65	400	0.1575	0.25	63	78.75
65	400	0.250	0.40	100	125.0
80	400	0.250	0.40	100	125.0
80	400	0.400	0.64	160	200.0
100	400	0.400	0.64	160	200.0
100	400	0.625	1.00	250	312.5
125	400	0.625	1.00	250	312.5
125	400	1.000	1.60	400	500.0
150	400	1.000	1.60	400	500.0
150	400	1.575	2.52	630	787.5
200	400	1.575	2.52	630	787.5
250	400	2.500	4.00	1000	1250
300	400	4.000	6.40	1600	2000
350	160	15.625	25.0	2500	3125
400	160	25.000	40.0	4000	5000
450	160	25.000	40.0	4000	5000
500	160	39.375	63.00	6300	7875
600	160	63.000	100.80	6300	7875

2.2.2 MID Annex MI-001

All new designs of water meters that are to be used for legal purposes in Europe require certification under the Measurement Instrument Directive (MID) 2004/22/EC.

Annex MI-001 of the MID applies to water meters intended for the measurement of volume of clean, cold or heated water in residential, commercial and light industrial use. An EC-type examination certificate is valid in all countries of the European Union.

The WATERFLUX 3070 has an EC-type examination certificate and can be verified to the MID Annex MI-001 for water meters with diameter DN25...DN600. The conformity assessment procedure followed for WATERFLUX 3070 is Module B (Type Examination) and Module D (Quality Assurance of the Production Process).

The maximum permissible error on volumes delivered between Q2 (transitional) flow rate and Q4 (overload) flow rate is $\pm 2\%$.

The maximum permissible error on volumes delivered between Q1 (minimum) flow rate and Q2 (transitional) flow rate is $\pm 5\%$.

Refer to the technical datasheet of WATERFLUX 3070 for further details of the certification.

$$Q1 = Q3 / R$$

$$Q2 = Q1 * 1.6$$

$$Q3 = Q1 * R$$

$$Q4 = Q3 * 1.25$$

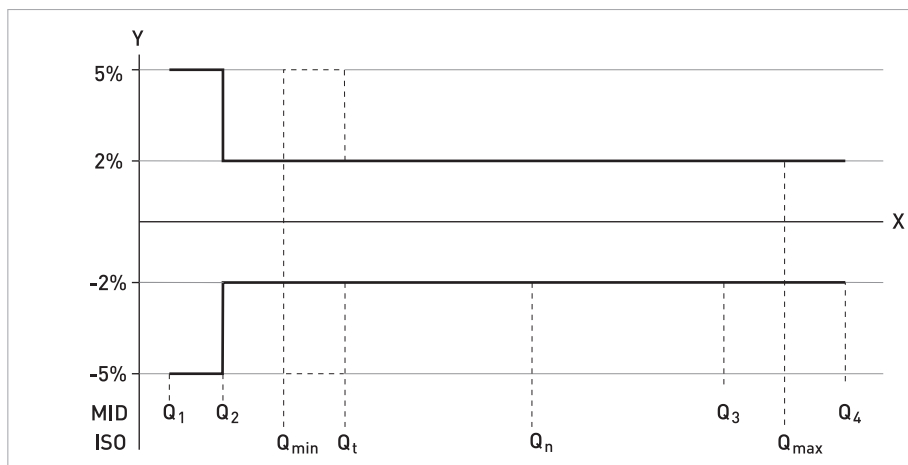

Figure 2-2: ISO flow rates added to figure as comparison towards MID

X: Flow rate

Y [%]: Maximum measuring error

MI-001 certified flow characteristics

DN	Span (R) Q3 / Q1	Flow rate [m ³ /h]			
		Minimum Q1	Transitional Q2	Permanent Q3	Overload Q4
25	400	0.025	0.040	10	12.5
25	400	0.040	0.064	16	20.0
25	640	0.025	0.040	16	20.0
40	400	0.0625	0.100	25	31.25
40	400	0.10	0.160	40	50.0
40	640	0.0625	0.100	40	50.0
50	400	0.10	0.160	40	50.0
50	400	0.158	0.252	63	78.75
50	630	0.100	0.160	63	78.75
65	400	0.158	0.252	63	78.75
65	400	0.25	0.400	100	125.0
65	635	0.1575	0.252	100	125.0
80	400	0.25	0.400	100	125.0
80	400	0.40	0.640	160	200.0
80	640	0.25	0.400	160	200.0
100	400	0.40	0.640	160	200.0
100	400	0.625	1.00	250	312.5
100	625	0.40	0.640	250	312.5
125	400	0.625	1.00	250	312.5
125	400	1.00	1.60	400	500.0
125	640	0.625	1.00	400	500.0
150	400	1.00	1.60	400	500.0
150	400	1.575	2.52	630	787.5
150	630	1.00	1.60	630	787.5
200	400	1.575	2.52	630	787.5
200	315	2.540	4.06	800	1000
200	508	1.575	2.52	800	1000
250	400	2.50	4.00	1000	1250
300	400	4.00	6.40	1600	2000
350	160	15.625	25.0	2500	3125
400	160	25.00	40.0	4000	5000
450	160	25.00	40.0	4000	5000
500	160	39.375	63.0	6300	7875
600	100	63.00	100.8	6300	7875

Verification to MI-001 and to OIML R49 class 2 is carried out at the following values for R, Q1, Q2 and Q3.

Verification to OIML R49 class 1 and at other values for R and Q3 available on request.

Verification to MI-001

DN	Span (R)	Flow rate [m ³ /h]		
		Q1	Q2	Q3
25	80	0.050	0.08	4
40	80	0.125	0.20	10
50	80	0.200	0.32	16
65	80	0.313	0.50	25
80	80	0.500	0.80	40
100	80	0.788	1.26	63
125	80	1.250	2.00	100
150	80	2.000	3.20	160
200	80	3.125	5.00	250
250	80	5.000	8.00	400
300	80	7.875	12.60	630
350	80	8.00	12.80	640
400	80	9.00	14.40	720
450	80	10.00	16.00	800
500	80	11.00	17.60	880
600	80	12.00	19.20	960

2.3 Measurement accuracy

Each water meter is standard wet calibrated under reference conditions by direct volume comparison. The performance of the water meter is defined and documented in an individual water meter calibration certificate.

Reference conditions

- Medium: water
- Temperature: +10...30°C / +50...68°F
- Pressure: 1 bar / 14.5 psi
- Inlet section: ≥ 3 DN
- Outlet section: ≥ 1 DN

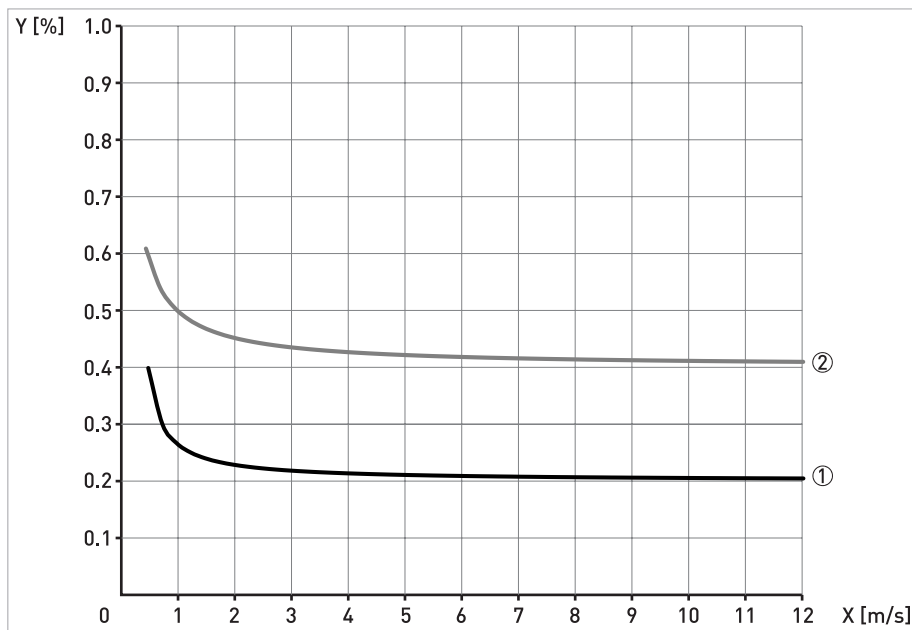

Figure 2-3: Measuring accuracy
 X [m/s]: Flow velocity; Y [%]: Maximum measuring error

Accuracy with IFC 070 converter

	Inlet	Outlet	Accuracy	Curve
DN25...300 / 1...12"	3 DN	1 DN	0.2% + 1 mm/s	①
DN350...600 / 14...24"	3 DN	1 DN	0.4% + 1 mm/s	②

2.3.1 WATERFLUX 3070 without straight inlet and outlet sections

Disturbed flow profiles, such as those that occur behind elbows, tee pieces, reducers or valves installed in front of a water meter, affect the measuring performance. Therefore it is usually recommended to fit a straight inlet length in front of and straight outlet length behind a water meter.

As a result of the unique WATERFLUX flow sensor design, whereby the mean flow velocity and flow profile are optimised within the rectangular and reduced cross section, the additional uncertainty for upstream disturbances are drastically reduced. Therefore the requirements for straight length and in front of and behind a meter are reduced.

The NMI has performed tests with various flow and swirl disturbers according to ISO 4064 and EN 14154. Based on these results the WATERFLUX 3070 has received a

OIML R49 certificate

- Diameter range DN25...600
- Accuracy class 1 and class 2
- Minimum straight inlet and outlet pipe length of 0 DN
- Bi-directional flow

EC-type certificate according MID Annex MI-001

- Diameter range DN25...600
- Minimum straight inlet and outlet pipe length of 0 DN
- Bi-directional flow

2.4 Dimensions and weights

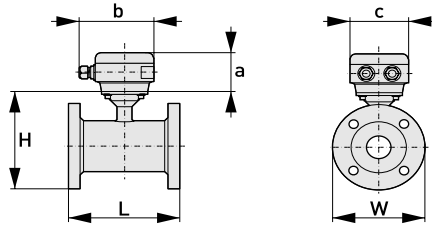
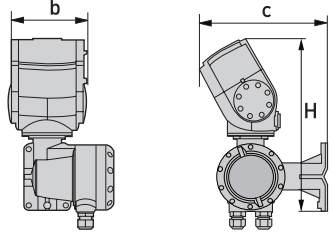
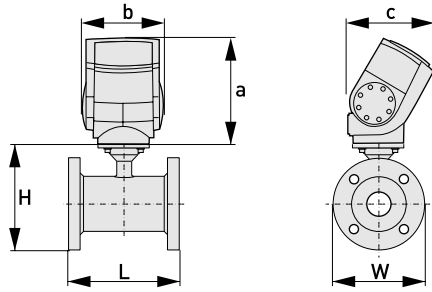
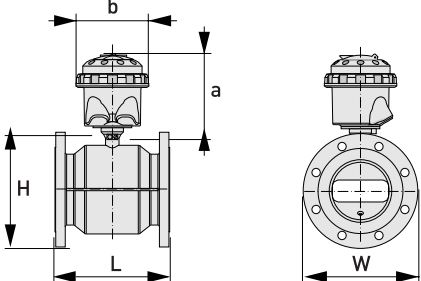
<p>Remote flow sensor</p>		<p>a = 88 mm / 3.5"</p> <p>b = 139 mm / 5.5" ①</p> <p>c = 106 mm / 4.2"</p> <p>Total height = H + a</p>
<p>Remote version in aluminium housing (IP67)</p>		<p>b = 132 mm / 5.2"</p> <p>c = 235 mm / 9.3"</p> <p>H = 310 mm / 12.2"</p> <p>Weight = 3.3 kg / 7.3 lb</p>
<p>Compact version in aluminium housing (IP67)</p>		<p>a = 170 mm / 6.7"</p> <p>b = 132 mm / 5.2"</p> <p>c = 140 mm / 5.5"</p> <p>Total height = H + a</p>
<p>Compact version in polycarbonate housing (IP68)</p>		<p>a = 159 mm / 6.3"</p> <p>b = 161 mm / 6.3"</p> <p>Total height = H + a</p>

① The value may vary depending on the used cable glands.

- All data given in the following tables are based on standard versions of the flow sensor only.
- Especially for smaller nominal sizes of the flow sensor, the signal converter can be bigger than the flow sensor.
- Note that for other pressure ratings than mentioned, the dimensions may be different.
- For full information on signal converter dimensions see relevant documentation.

EN 1092-1

Nominal size DN [mm]	Dimensions [mm]			Approx. weight [kg]
	L	H	W	
25	150	151	115	5
40	150	166	150	6
50	200	186	165	13
65	200	200	185	11
80	200	209	200	17
100	250	237	220	17
125	250	266	250	21
150	300	300	285	29
200	350	361	340	36
250	400	408	395	50
300	500	458	445	60
350	500	510	505	85
400	600	568	565	110
450	600	618	615	125
500	600	671	670	120
600	600	781	780	180

ASME B16.5 / 150 lb

Nominal size [inches]	Dimensions [inches]			Approx. weight [lb]
	L	H	W	
1	5.91	5.83	4.3	18
1½	5.91	6	4.9	21
2	7.87	7.05	5.9	34
3	7.87	8.03	7.5	42
4	9.84	9.49	9.0	56
5	9.84	10.55	10.0	65
6	11.81	11.69	11.0	80
8	13.78	14.25	13.5	100
10	15.75	16.3	16.0	148
12	19.7	18.8	19.0	210
14	27.6	20.7	21	290
16	31.5	22.9	23.5	370
18	31.5	24.7	25	420
20	31.5	27	27.5	500
24	31.5	31.4	32	680

2.5 Pressure loss

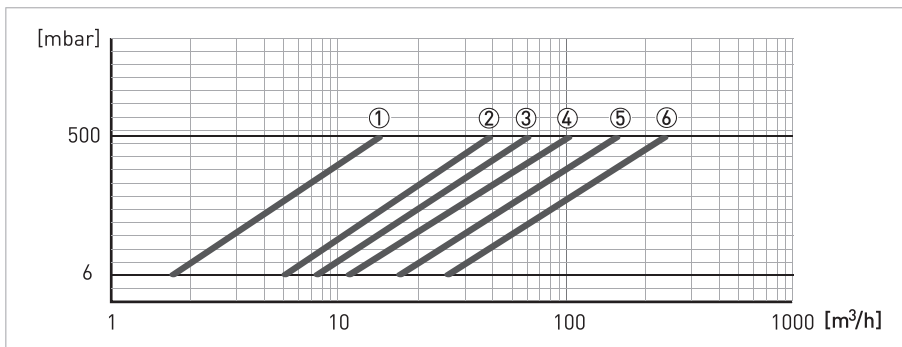

Figure 2-4: Pressure loss between 1 m/s and 9 m/s for DN25...100

- ① DN25
- ② DN40
- ③ DN50
- ④ DN65
- ⑤ DN80
- ⑥ DN100

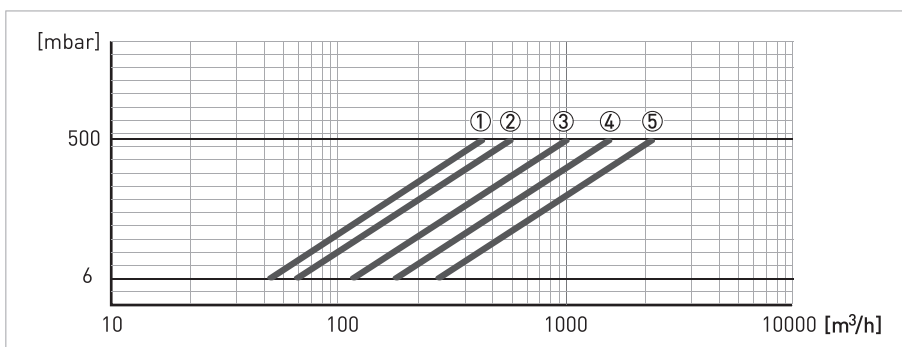

Figure 2-5: Pressure loss between 1 m/s and 9 m/s for DN125...300

- ① DN125
- ② DN150
- ③ DN200
- ④ DN250
- ⑤ DN300

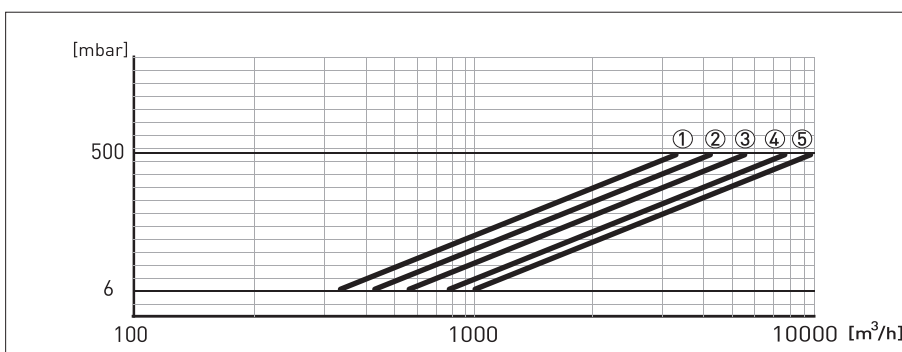

Figure 2-6: Pressure loss between 1 m/s and 9 m/s for DN350...600

- ① DN350
- ② DN400
- ③ DN450
- ④ DN500
- ⑤ DN600

2.6 Battery lifetime

The maximum battery lifetime depends on the choice of battery pack, the diameter and on the measurement interval. Other factors influencing the battery lifetime include the ambient temperature, the pulse output settings, the status output, and the pulse width. The graphs show the battery lifetime for the different available battery types and measurement intervals.

Conditions

The maximum battery lifetime is based on default menu settings, an ambient temperature of 25°C / 77°F and a flow rate at 2 m/s. The effect of the optional pressure and temperature sensor decreases the battery lifetime with 5% (on average).

Maximum lifetime of batteries for: DN25...200

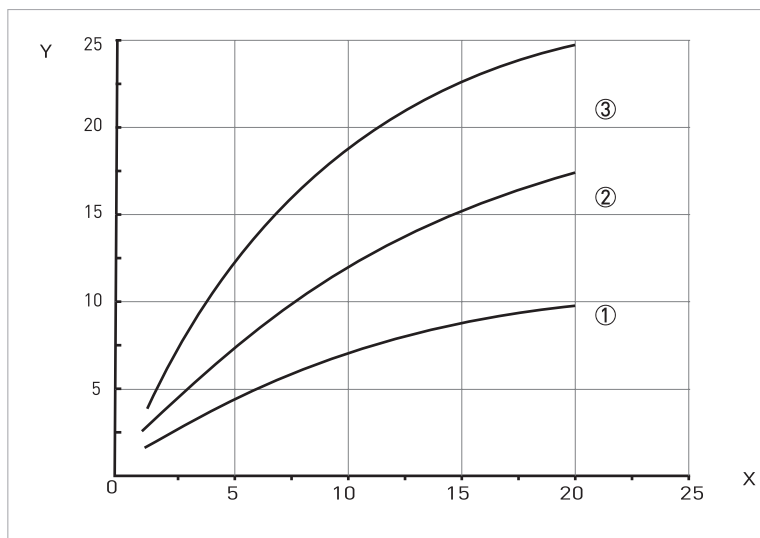

Figure 2-7: X = Measuring interval in seconds, Y = typical lifetime in years

Maximum lifetime of batteries for: DN250...600

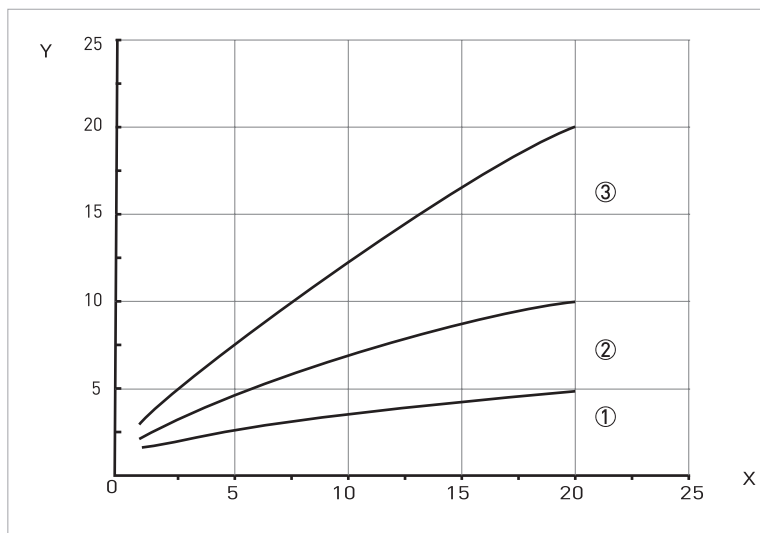

Figure 2-8: X = Measuring interval in seconds, Y = typical lifetime in years

- ① Single D-cell battery
- ② Dual D-cell battery
- ③ External battery

3.1 General notes on installation

Inspect the packaging carefully for damages or signs of rough handling. Report damage to the carrier and to the local office of the manufacturer.

Do a check of the packing list to make sure that you have all the elements given in the order.

Look at the device nameplate to ensure that the device is delivered according to your order. Check for the correct supply voltage printed on the nameplate.

3.2 Intended use

Responsibility for the use of the measuring devices with regard to suitability, intended use and corrosion resistance of the used materials against the measured fluid lies solely with the operator.

The manufacturer is not liable for any damage resulting from improper use or use for other than the intended purpose.

This flowmeter is designed exclusively to measure the flow of drinking water, raw water and irrigation water.

If the device is not used according to the operating conditions (refer to chapter Technical data), the intended protection could be affected.

3.3 Pre-installation requirements

Make sure that you have all necessary tools available:

- Allen key (4 mm)
- Small screwdriver
- Wrench for cable glands
- Wrench for wall mounting bracket (remote version only)
- Torque wrench for installing flowmeter in pipeline

3.4 General requirements

The following precautions must be taken to ensure reliable installation.

- Make sure that there is adequate space to the sides.
- Protect the signal converter from direct sunlight and install a sun shade if necessary.
- Signal converters installed in control cabinets require adequate cooling, e.g. by fan or heat exchanger.
- Do not expose the signal converter to intense vibration. The flowmeters are tested for a vibration level in accordance with IEC 68-2-64.

3.4.1 Vibration

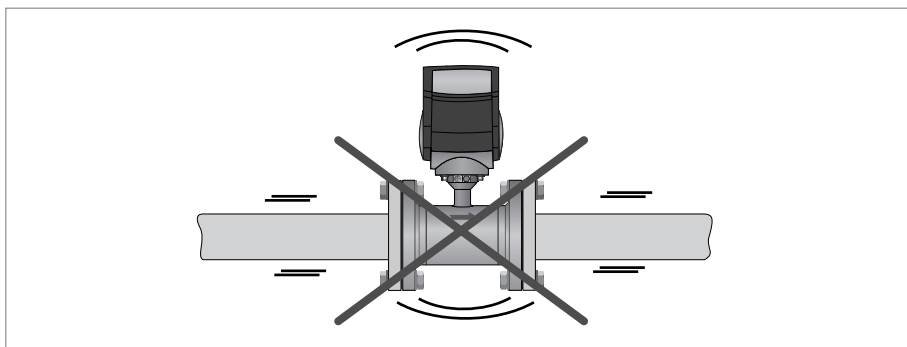

Figure 3-1: Avoid vibrations

3.4.2 Magnetic field

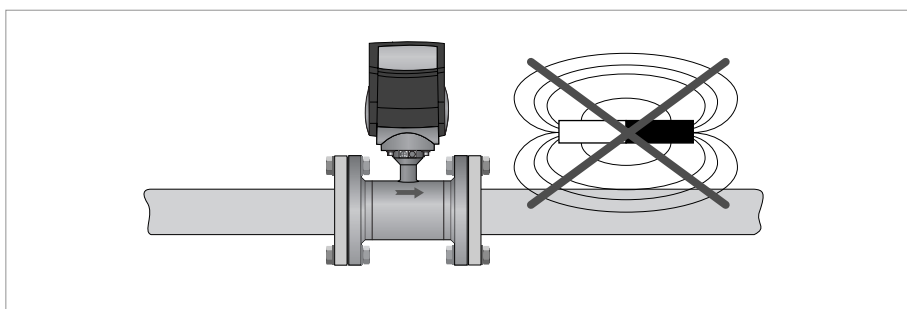

Figure 3-2: Avoid magnetic fields

3.5 Installation conditions

3.5.1 Inlet and outlet

DN25...300

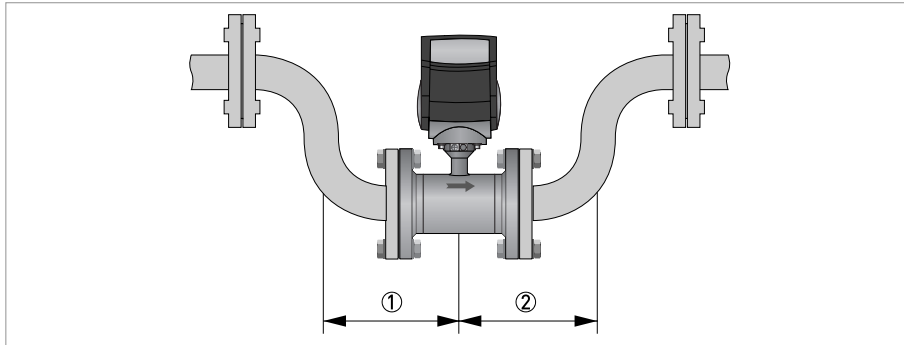

Figure 3-3: Minimal inlet and outlet

- ① Inlet: ≥ 0 DN
- ② Outlet: ≥ 0 DN

DN350...600

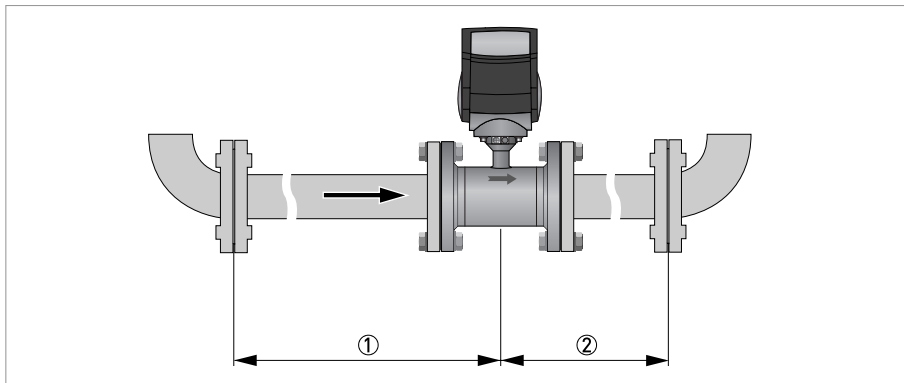

Figure 3-4: Minimal inlet and outlet

- ① Inlet: ≥ 3 DN
- ② Outlet: ≥ 1 DN

3.5.2 T-section

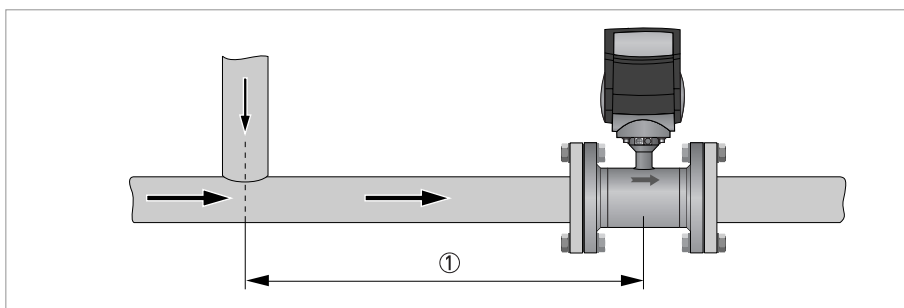

Figure 3-5: Distance behind a T-section

- ① DN 25...300: ≥ 0 DN
- DN 350...600: ≥ 3 DN

3.5.3 Bends

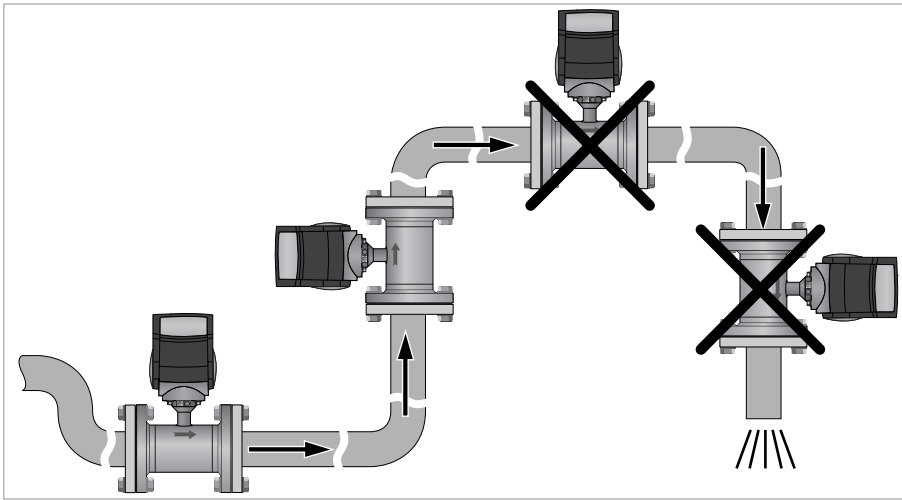

Figure 3-6: Installation in bending pipes

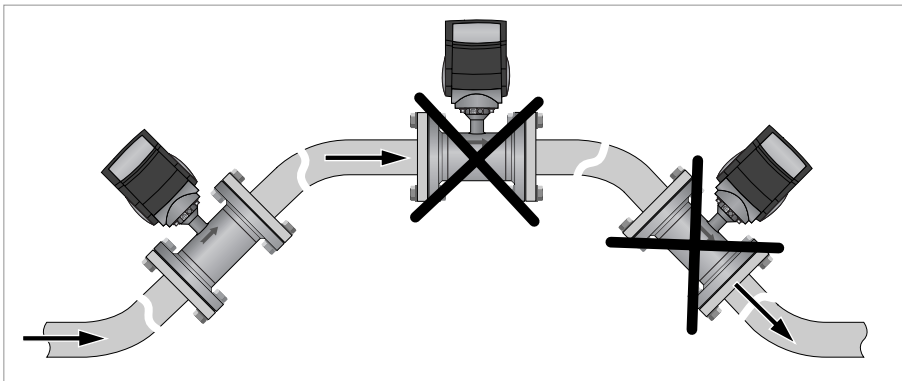

Figure 3-7: Installation in bending pipes

Avoid draining or partial filling of the flow sensor

3.5.4 Open feed or discharge

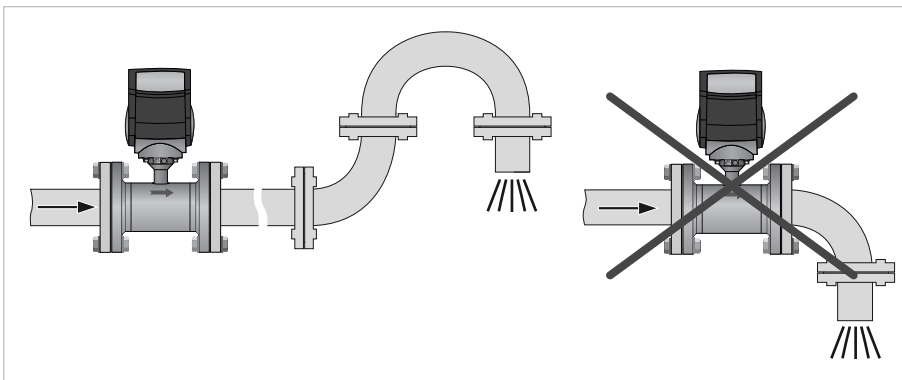

Figure 3-8: Installation in front of an open discharge

3.5.5 Pump

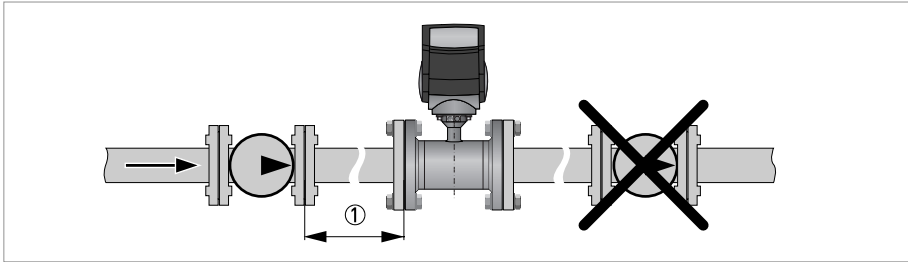

Figure 3-9: Recommended installation: behind a pump

① Inlet: ≥ 3 DN

3.5.6 Control valve

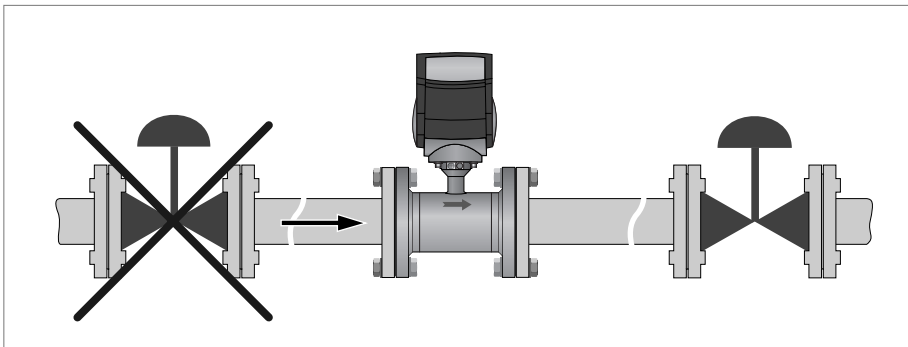

Figure 3-10: Recommended installation: in front of a control valve

3.5.7 Air venting and vacuum forces

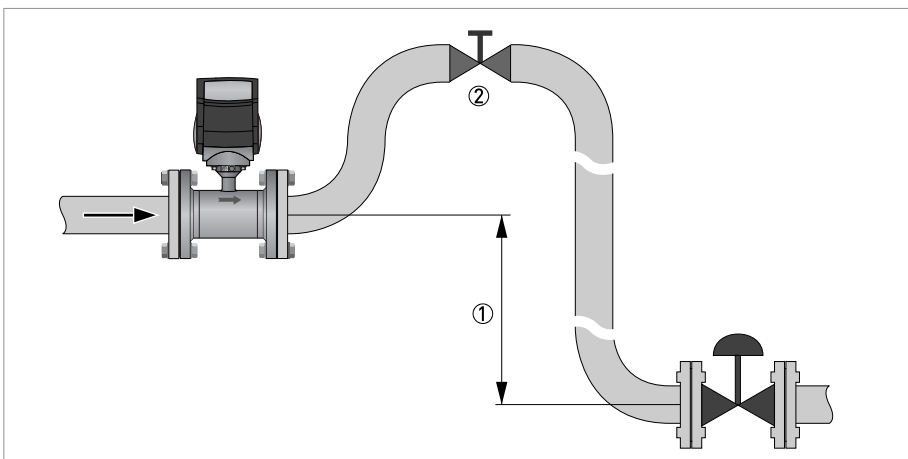

Figure 3-11: Air venting

① ≥ 5 m

② Air ventilation point

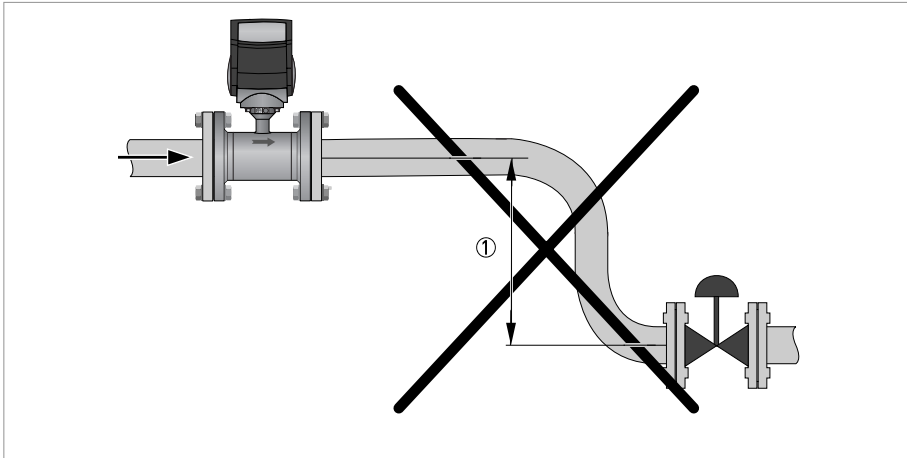

Figure 3-12: Vacuum

① ≥ 5 m

3.5.8 Mounting position and flange deviation

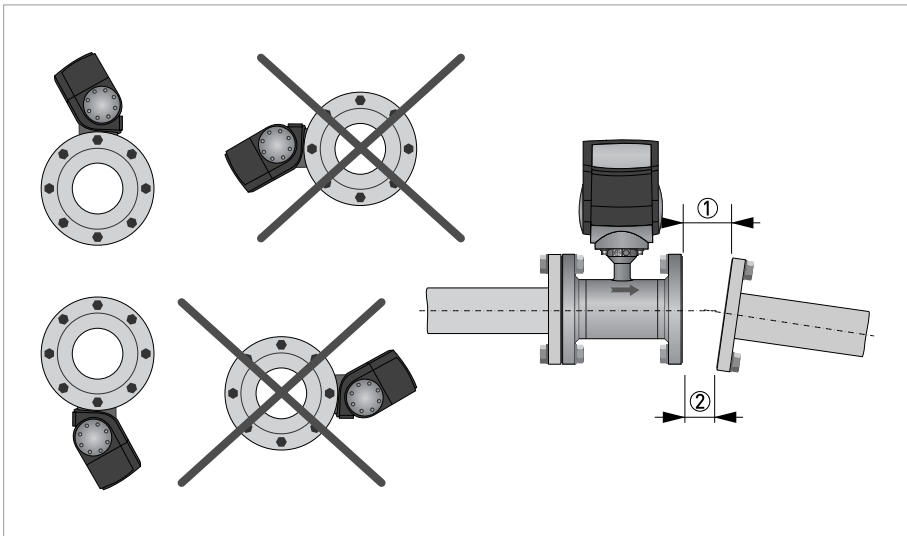

Figure 3-13: Mounting position and flange deviation

① L_{max}

② L_{min}

- Mount flow sensor either with signal converter aligned upwards or downwards.
- Install flow sensor in line with the pipe axis.
- Pipe flange faces must be parallel to each other.

Max. permissible deviation of pipe flange faces: $L_{max} - L_{min} \leq 0.5 \text{ mm} / 0.02''$.

3.5.9 IP68

The WATERFLUX 3000 flow sensor is rated IP68 (NEMA 4X/6P). It is suitable for submersion in flooded measurement chambers and for subsurface installation.

The compact IFC 070 signal converter is available in:

- an aluminium housing suitable for IP66/67, NEMA 4/4X/6
- a polycarbonate housing suitable for IP68, NEMA 4/4X/6.
This version is suitable for periodic submersion in flooded measurement chambers. The output cable has IP68 rated (military) connectors.
In case of continuous or long term submersion it is advised to select the field (remote) version (IP66/67). Submersion under water is possible down to a depth of 5 meters.

The remote IFC 070 signal converter is available in:

- an aluminium housing suitable for IP66/67, NEMA 4/4X/6.

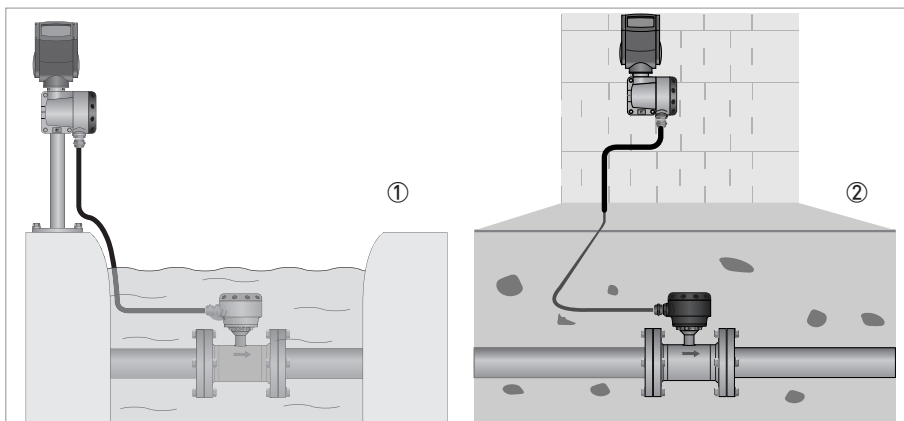

Figure 3-14: IP68 versions

- ① Submersible
- ② Buried

Note; figures shows a cable ≤ 25 meter

3.6 Mounting

3.6.1 Torques and pressures

The maximum pressure and torques values for the flowmeter are theoretical and calculated for optimum conditions and use with carbon steel flanges.

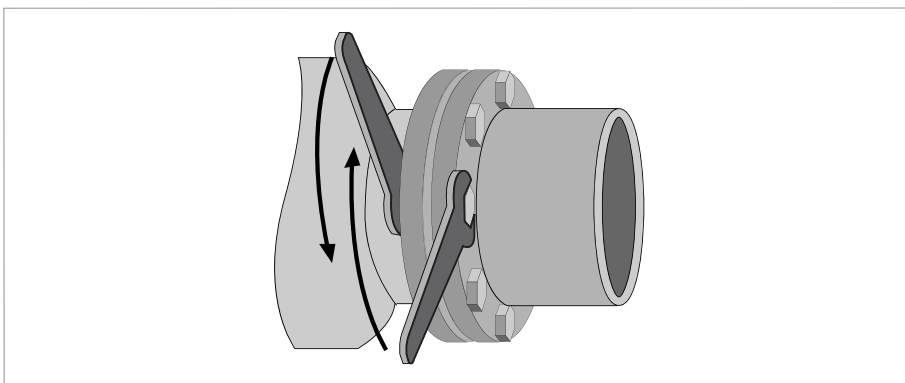

Figure 3-15: Tightening of bolts

Tightening of bolts

- Always tighten the bolts uniformly and in diagonally opposite sequence.
- Do not exceed the maximum torque value.
- Step 1: Apply approx. 50% of max. torque given in table.
- Step 2: Apply approx. 80% of max. torque given in table.
- Step 3: Apply 100% of max. torque given in table.

Nominal size DN [mm]	Pressure rating	Bolts	Max. torque [Nm] ^①
25	PN 16	4 x M 12	12
40	PN 16	4 x M 16	30
50	PN 16	4 x M 16	36
65	PN 16	8 x M 16	50
80	PN 16	8 x M 16	30
100	PN 16	8 x M 16	32
125	PN 16	8 x M 16	40
150	PN 10	8 x M 20	55
150	PN 16	8 x M 20	55
200	PN 10	8 x M 20	85
200	PN 16	12 x M 20	57
250	PN 10	12 x M 20	80
250	PN 16	12 x M 24	100
300	PN 10	12 x M 20	95
300	PN 16	12 x M 24	136
350	PN 10	16 x M 20	96
400	PN 10	16 x M 24	130
450	PN 10	20 x M 24	116
500	PN 10	20 x M 24	134
600	PN 10	20 x M 27	173

① The torque values also depend on variables (temperature, bolt material, gasket material, lubricants, etc.) outside the control of the manufacturer. Therefore these values should be regarded as indicative only.

Nominal size [inches]	Flange class [lb]	Bolts	Max. torque [lbs.ft] ^①
1	150	4 x 1/2"	4
1½	150	4 x 1/2"	11
2	150	4 x 5/8"	18
2.5	150	8 x 5/8"	27
3	150	4 x 5/8"	33
4	150	8 x 5/8"	22
5	150	8 x 3/4"	33
6	150	8 x 3/4"	48
8	150	8 x 3/4"	66
10	150	12 x 7/8"	74
12	150	12 x 7/8"	106
14	150 ②	12 x 1"	87
16	150 ②	16 x 1"	84
18	150 ②	16 x 1 1/8"	131
20	150 ②	20 x 1 1/8"	118
24	150 ②	20 x 1 1/4"	166

① The torque values also depend on variables (temperature, bolt material, gasket material, lubricants, etc.) outside the control of the manufacturer. Therefore these values should be regarded as indicative only.

② No full rating (max. 150 psi/ 10 bar).

3.7 Mounting of the signal converter

Assembly materials and tools are not part of the delivery. Use the assembly materials and tools in compliance with the applicable occupational health and safety directives.

3.7.1 IP67 housing, remote version

Pipe mounting

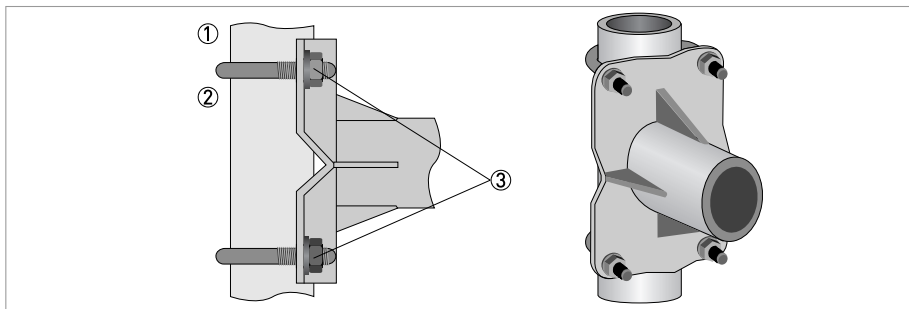

Figure 3-16: Pipe mounting of the field housing

- ① Fix the signal converter to the pipe.
- ② Fasten the signal converter using standard U-bolts and washers.
- ③ Tighten the nuts.

Wall mounting: no special requirements.

3.7.2 IP68 housing, compact version

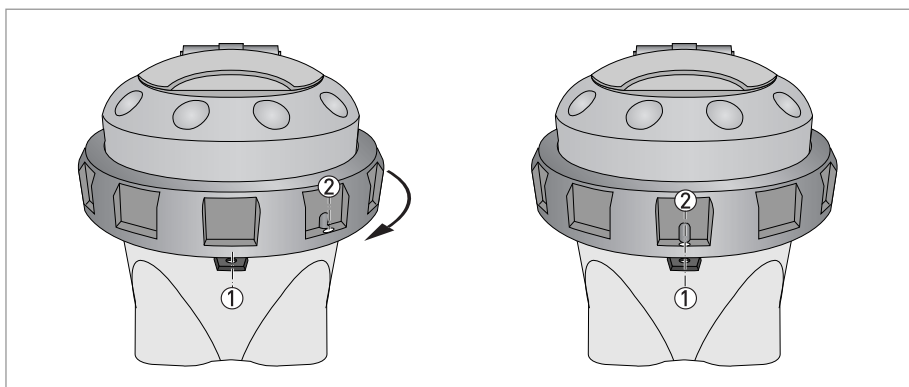

Figure 3-17: Closing of IP68 housing

- Before closing the case of the converter, ensure that all surfaces in contact with the seals are clean.
- Position the upper part of the case and tighten the lock ring, up until the positions of points ① and ② are in line (do not tighten the ring any further).
- Use the special wrench to tighten the ring as advised above.

4.1 Safety instructions

All work on the electrical connections may only be carried out with the power disconnected. Take note of the voltage data on the nameplate!

Observe the national regulations for electrical installations!

Observe without fail the local occupational health and safety regulations. Any work done on the electrical components of the measuring device may only be carried out by properly trained specialists.

Look at the device nameplate to ensure that the device is delivered according to your order. Check for the correct supply voltage printed on the nameplate.

4.2 Grounding

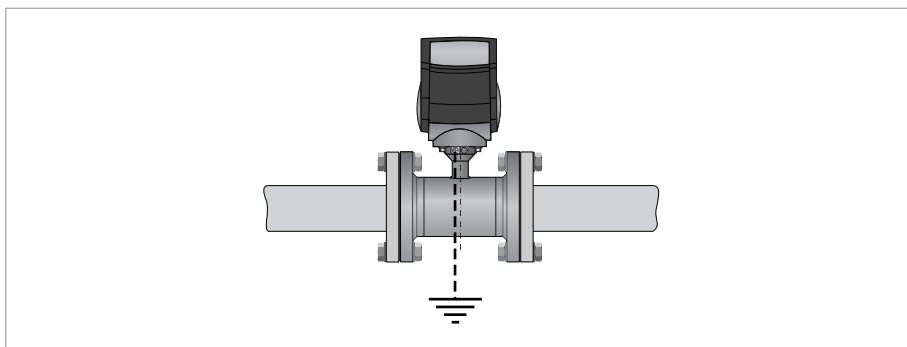

Figure 4-1: Grounding

Grounding without grounding rings. The flow sensor is equipped with a reference electrode.

4.3 Connection of the signal cable WSC (25 meter and shorter)

4.3.1 IP 67 housing (field version)

To ensure smooth functioning, always use the signal cables included in the delivery.

The signal cable is only used for remote versions. The standard WSC-cable with max length of 25 meter, includes both electrode and field current leads. Other lengths on request

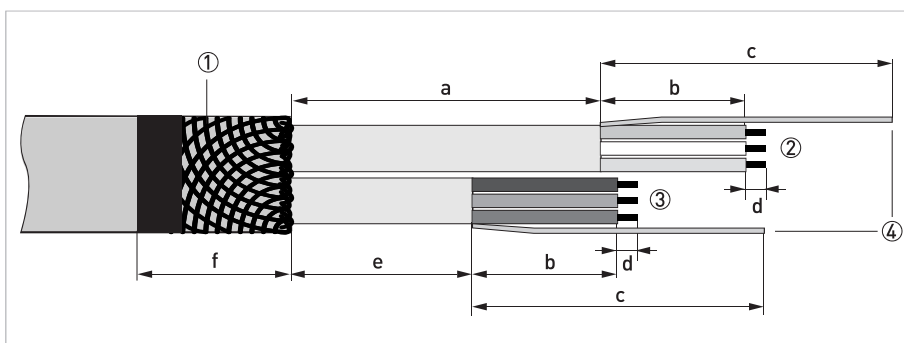

Figure 4-2: Preparation of standard cable (both sides)

- ① Shielding
- ② Blue + green + yellow cable, used for field current (terminals 7, 8, 9)
- ③ Brown + white + violet cable, used for electrode signals (terminals 1, 2, 3)
- ④ Drain wires

Dimensions of cable

	a	b	c	d	e	f
mm	75	35	70	5	45	30
inch	3.0	1.4	2.8	0.2	1.8	1.2

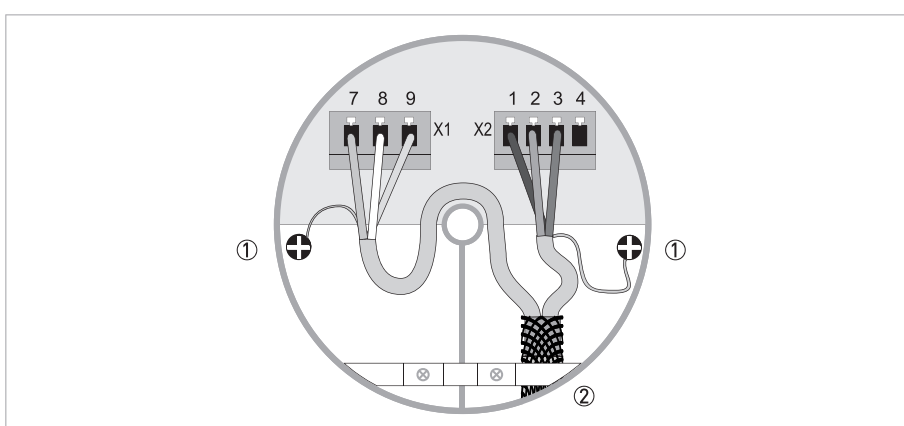

Figure 4-3: Cable connection at sensor side, standard cable

- ① Connect drain wires under screw
- ② Connect shielding under clamp

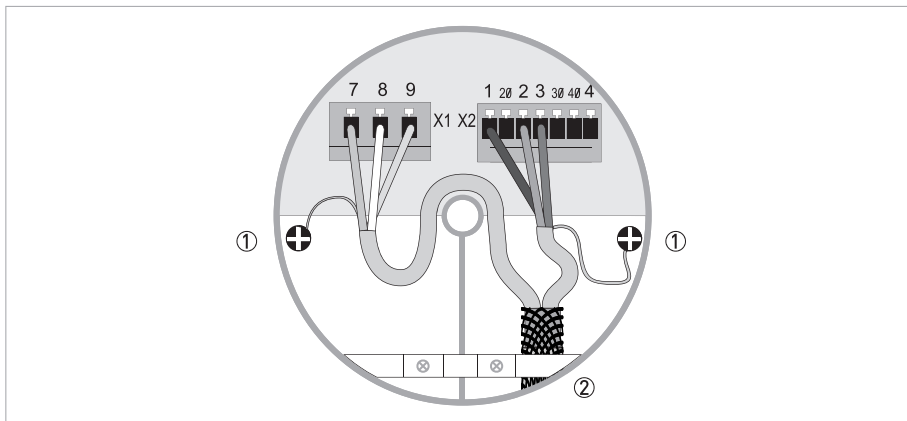

Figure 4-4: Cable connection at converter side, standard cable

- ① Connect drain wires under screw
- ② Connect shielding under clamp

- Prepare appropriate cable lengths as shown.
- Connect the wires as shown in the following table.

Wire color	Terminal	Function
Brown	1	Reference electrode
White	2	Standard electrode signal
Violet	3	Standard electrode signal
Blue	7	Field current
Green	8	Field current
Yellow	9	No function
Drain wires	Screws	Shielding

4.3.2 Requirements for signal cables provided by the customer

If the signal cable was not ordered, it is to be provided by the customer. The following requirements regarding the electrical values of the signal cable must be observed:

Electrical safety

- To EN 60811 (Low Voltage Directive) or equivalent national regulations.

Capacitance of the insulated conductors

- Insulated conductor / insulated conductor < 50 pF/m
- Insulated conductor / shield < 150 pF/m

Insulation resistance

- $R_{iso} > 100 \text{ G}\Omega \times \text{km}$
- $U_{max} < 24 \text{ V}$
- $I_{max} < 100 \text{ mA}$

Test voltages

- Insulated conductor / inner shield 500 V
- Insulated conductor / insulated conductor 1000 V
- Insulated conductor / outer shield 1000 V

Twisting of the insulated conductors

- At least 10 twists per meter, important for screening magnetic fields.

4.3.3 Signal cable A (type DS 300), construction

- Signal cable A is a double-shielded cable for signal transmission between the measuring sensor and signal converter.
- Bending radius: $\geq 50 \text{ mm} / 2''$

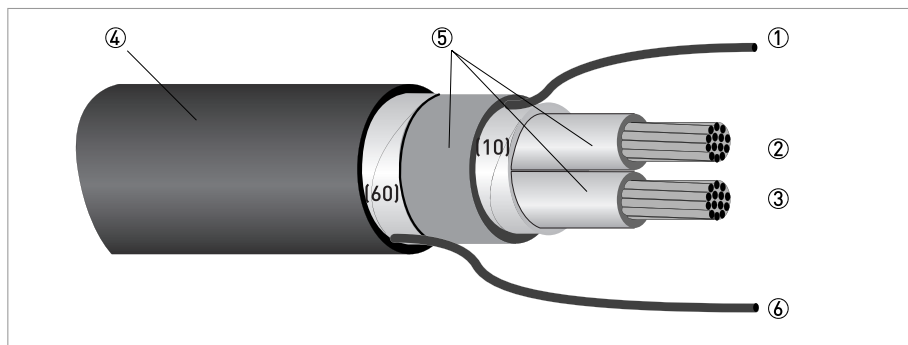

Figure 4-5: Construction of signal cable A

- ① Stranded drain wire (1) for the inner shield (10), $1.0 \text{ mm}^2 \text{ Cu} / \text{AWG } 17$ (not insulated, bare)
- ② Insulated wire (2), $0.5 \text{ mm}^2 \text{ Cu} / \text{AWG } 20$
- ③ Insulated wire (3), $0.5 \text{ mm}^2 \text{ Cu} / \text{AWG } 20$
- ④ Outer sheath
- ⑤ Insulation layers
- ⑥ Stranded drain wire (6) for the outer shield (60)

4.3.4 Preparing signal cable A (25 meter and longer) and connection to measuring sensor

Assembly materials and tools are not part of the delivery. Use the assembly materials and tools in compliance with the applicable occupational health and safety directives.

- The outer shield (60) is connected in the terminal compartment of the measuring sensor directly via the shield and a clip.
- Bending radius: $\geq 50 \text{ mm} / 2''$

Required materials

- PVC insulating tube, $\varnothing 2.0 \dots 2.5 \text{ mm} / 0.08 \dots 0.1''$
- Heat-shrinkable tubing
- Wire end ferrule to DIN 46 228: E 1.5-8 for the stranded drain wire (1)
- 2 wire end ferrules to DIN 46 228: E 0.5-8 for the insulated conductors (2, 3)

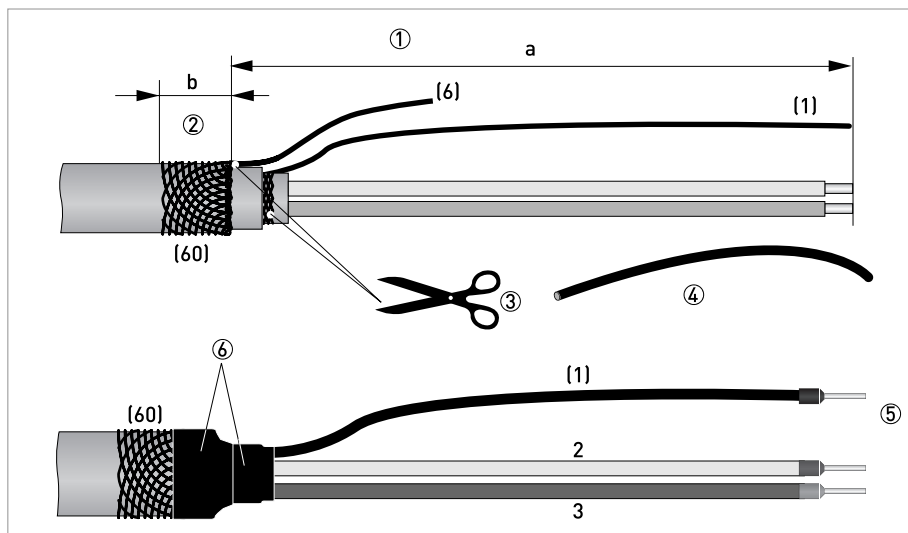

Figure 4-6: Preparing signal cable A, connection to measuring sensor and converter

$a = 85 \text{ mm} / 2''$

$b = 10 \text{ mm} / 0.39''$

- ① Strip the conductor to dimension a.
- ② Trim the outer shield (60) to dimension b and pull it over the outer sheath.
- ③ Remove the stranded drain wire (6) of the outer shield and the inner shield. Make sure not to damage the stranded drain wire (1) of the inner shield.
- ④ Slide an insulating tube over the stranded drain wire (1).
- ⑤ Crimp the wire end ferrules onto conductors 2 and 3 and the stranded drain wire (1).
- ⑥ Pull the heat-shrinkable tubing over the prepared signal cable.

Cable connection

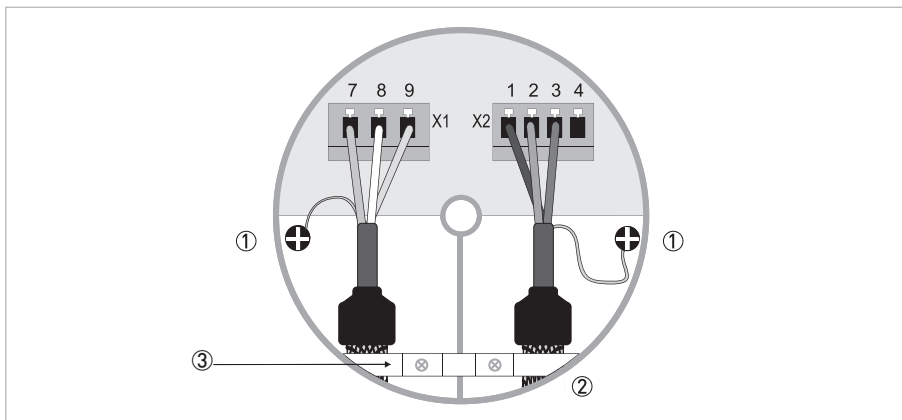

Figure 4-7: Cable connection at sensor and converter side, DS300 cable A

- ① Connect drain wires under screw
- ② DS300 cable A
- ③ Connect shielding under clamp

4.4 Connection of the output cable

4.4.1 IP67 housing (compact and field version)

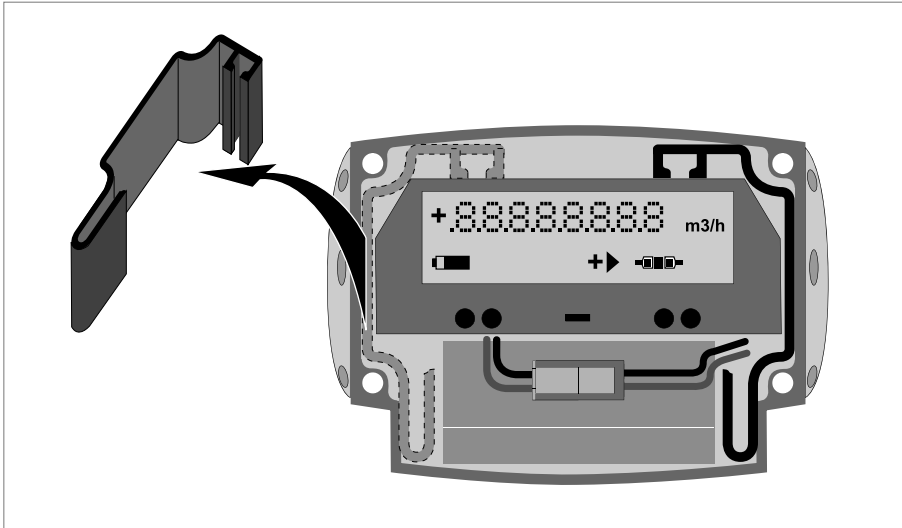

Figure 4-8: Removing side cap

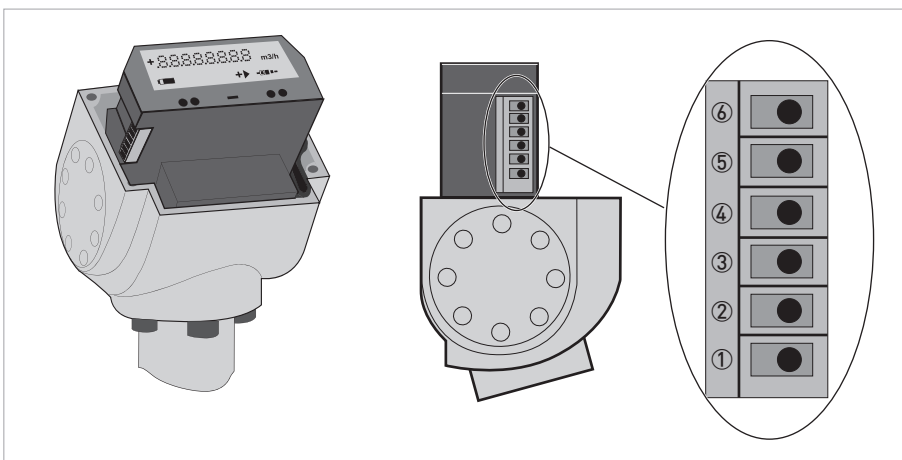

Figure 4-9: Terminal assignment

- ① Status output 1 or threshold for P or T or pulse output C
- ② Status output 2 or threshold for P or T
- ③ Not used
- ④ Common ground
- ⑤ Pulse output A
- ⑥ Pulse output B

Electrical values

- **Pulse output passive:**
 $f \leq 100 \text{ Hz}$; $I \leq 10 \text{ mA}$; $U: 2.7 \dots 24 \text{ VDC}$ ($P \leq 100 \text{ mW}$)
- **Status output passive:**
 $I \leq 10 \text{ mA}$; $U: 2.7 \dots 24 \text{ VDC}$ ($P \leq 100 \text{ mW}$)

4.4.2 IP68 housing (compact version)

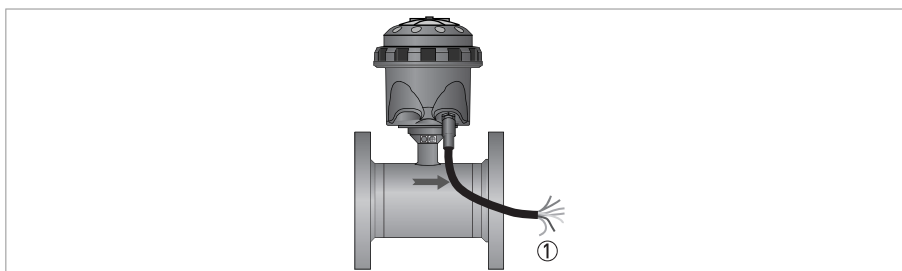

Figure 4-10: Output cable at IP68 compact version

① Color coded leads of output cable

If an output is activated, the output cable with the IP68 rated connector has the following leads:

Wire color	Contact on connector	Function
Yellow	A	Status output 1 or threshold for P or T or pulse output C
White	G	Status output 2 or threshold for P or T
Blue	H	Ground
Brown	B	Pulse output A
Green	F	Pulse output B
Pink	C	External battery +
Grey	E	External battery -

Electrical values

- **Pulse output passive:**
 $f \leq 100 \text{ Hz}$; $I \leq 10 \text{ mA}$; $U: 2.7 \dots 24 \text{ VDC}$ ($P \leq 100 \text{ mW}$)
- **Status output passive:**
 $I \leq 10 \text{ mA}$; $U: 2.7 \dots 24 \text{ VDC}$ ($P \leq 100 \text{ mW}$)









KROHNE product overview

- Electromagnetic flowmeters
- Variable area flowmeters
- Ultrasonic flowmeters
- Mass flowmeters
- Vortex flowmeters
- Flow controllers
- Level meters
- Temperature assemblies
- Pressure transmitters
- Analysis products
- Products and systems for the oil & gas industry
- Measuring systems for the marine industry

Head Office KROHNE Messtechnik GmbH
Ludwig-Krohne-Str. 5
47058 Duisburg (Germany)
Tel.: +49 203 301 0
Fax: +49 203 301 103 89
info@krohne.com

The current list of all KROHNE contacts and addresses can be found at:
www.krohne.com

KROHNE