

Operating Instructions
for
Turbine Wheel Flow Meter

Model: SFL



1. Contents

1. Contents.....	2
2. Note	3
3. Instrument Inspection.....	3
4. Regulation Use.....	3
5. Operating Principle.....	4
6. Mechanical Connection.....	5
7. Electrical Connection	6
8. Commissioning.....	7
9. Technical Information.....	7
10. Pressure-Loss	8
11. Order Codes	8
12. Maintenance	8
13. Dimensions	9
14. EU Declaration of Conformance.....	10

Manufactured and sold by:

Kobold Messring GmbH
Nordring 22-24
D-65719 Hofheim
Tel.: +49(0)6192-2990
Fax: +49(0)6192-23398
E-Mail: info.de@kobold.com
Internet: www.kobold.com

2. Note

Please read these operating instructions before unpacking and putting the unit into operation. Follow the instructions precisely as described herein.

The devices are only to be used, maintained and serviced by persons familiar with these operating instructions and in accordance with local regulations applying to Health & Safety and prevention of accidents.

When used in machines, the measuring unit should be used only when the machines fulfil the EC-machine guidelines.

PED 2014/68/EU

In acc. with Article 4 Paragraph (3), "Sound Engineering Practice", of the PED 2014/68/EU no CE mark.

Diagram 8, Pipe, Group 1 dangerous fluids

3. Instrument Inspection

Instruments are inspected before shipping and sent out in perfect condition.

Should damage to a device be visible, we recommend a thorough inspection of the delivery packaging. In case of damage, please inform your parcel service / forwarding agent immediately, since they are responsible for damages during transit.

Scope of delivery:

The standard delivery includes:

- Turbine Wheel Flow Meter, model: SFL
- Operating Instructions

4. Regulation Use

Any use of the SFL that exceeds the manufacturer's specifications may invalidate its warranty. Therefore any resulting damage is not the responsibility of the manufacturer. The user assumes all risk for such usage.

5. Operating Principle

The model SFL low volume flowmeter is particularly suitable for service in liquids free from solids. The liquids must be transmissive for infrared light (for example: water, oil, chemicals). The plastic or stainless steel material combination allows service in aggressive media.

The flowing medium causes the turbine wheel to rotate. Housing geometry, light-weight turbine wheel and radial flowing liquid ensure that the rotor floats. A suspended rotor ensures a long service life. The motion of the turbine wheel is sensed in a non-contacting manner with infrared diodes and converted to pulses. This output signal is linear and proportional to the volumetric flow. The flow meter may be installed in any position.

6. Mechanical Connection

- Ensure that the actual flow-volume does not exceed the measuring range of the unit.
- Ensure that the permitted maximum working pressure and temperature limits for SFL are not exceeded.
- Make sure that the power supply of the unit is in agreement with the operational data of the unit.
- Remove all the packing material meant for safe transportation and make sure that no packing material is located inside the unit.



The unit mounting is position-independent; however, the flow must always follow the arrow-direction.

- In particular, when flow is from top to bottom, ensure that the flow-chamber is filled completely by the medium. No additional up/downstream straight-run piping should be required.
- We advise the use of a prefilter with 20 µm.
- The sealing of the connection-threads should be accomplished by using Teflon-tape or similar material.
- During installation of the unit, it must be observed that no excessive torsion or tensile stress is applied to the connection threads. We recommend that the in and out lines should be mechanically supported at a distance of about 50 mm away from the connection fittings.



Attention! Exceeding the measuring range (over 20%) can damage the flowmeter. Please avoid compressed air in the pipe, which can damage the rotor blades very fast.

- If possible, after the mechanical installation is completed and checked, it should be tested for leaks in the pipe and connection-threads.

7. Electrical Connection



Attention! Make sure that the voltage level of your system is in agreement with the voltage level imprinted on the nameplate-tag.

- Make sure that the supply wires are de-energized.
- Connect the electrical cable with your power supply cable in the manner shown below.
- We recommend 0.25 mm² cross-sectional area for the power supply cable.



Attention! Incorrect wiring will lead to damage of the unit's electronics.

- After the feed-in voltage is supplied and the signal output is connected, the unit is ready for operation.

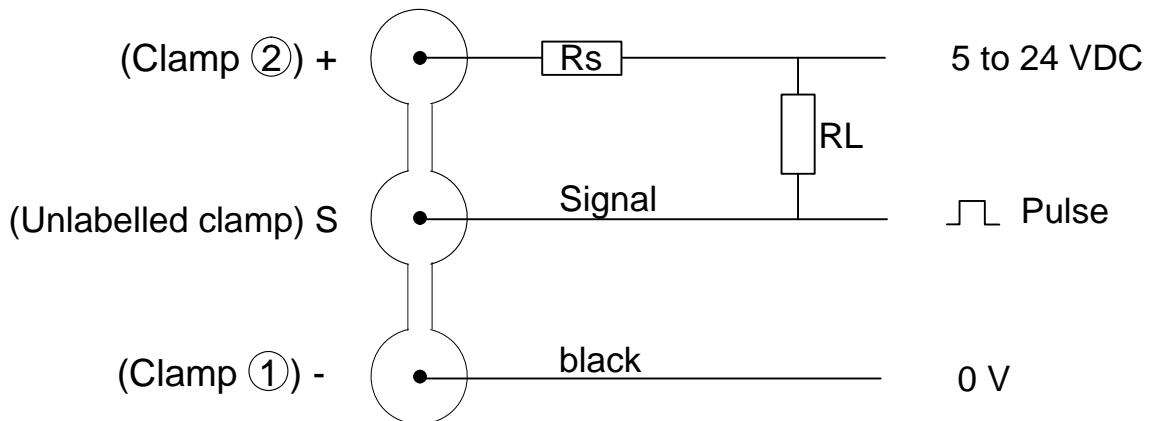

$$R_L = 2.2 \text{ k}\Omega$$

$$R_s = 50 \text{ }\Omega/\text{V} \times U$$

Example:

R_s with connection of 12 VDC feed-voltage

$$R_s = 50 \text{ }\Omega/\text{V} \times 12 \text{ V} = 600 \text{ }\Omega$$

8. Commissioning

- Please pay close attention to the technical specifications of this flowmeter.
- Check the connecting wires for polarity and voltage.
- Adjust the evaluating electronics for a pulse rate as mentioned in next chapter.
- Check if the pipe and connection-thread joint is properly sealed.
- To avoid excessive pressure conditions, the flow-medium should be introduced to the unit slowly.



Attention! Pressure spikes generated by abrupt inflow (through magnetic valves, ball-valves or similar) may cause destruction of the unit (via water hammer). During normal operation, it must be assured that the measuring transducer operates only when the chamber is filled with the medium.



Attention! Large air inclusions in the measuring chamber may lead to incorrect measurements as well as destruction of bearings.

9. Technical Information

Reaction value:	approx. 0.08 L/min
Max. medium temp.:	-20 to +90 °C
Max. operating pressure:	16 bar (SFL-13) 250 bar (SFL-12)
Measuring accuracy:	±1% f.s.
Repeatability:	± 0.3% of measured value
Interchangeability:	± 2.5% of measured value
Power supply:	5...24 V _{DC} (12...24 mA)
Output signal:	pulses approx. 100...2100 Hz (rectangle, no zero crossing)
K factor (approx.):	6100 pulses/litre (SFL-12...), 5400...6100 pulses/litre (SFL-13...)
Materials:	PVDF case and LCP O-Ring: EPDM (SFL-13) or stainless steel 1.4305 (case) and LCP O-Ring: FPM (SFL-12)
Mechanical connection:	G 3/8 male (SFL-13) or G 3/8 female (SFL-12)
Electrical connection:	3- core ribbon cable (app.15 cm) encapsulated in the case (SFL-13) Hirschmann connector GDSN207 (SFL-12)

10. Pressure-Loss

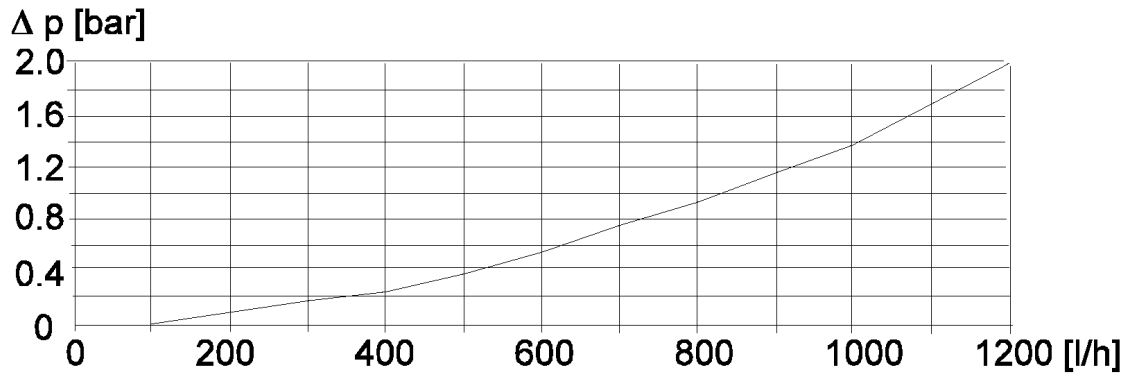

11. Order Codes

Model	Material, housing/rotor	Connection	Meas. range l/min water	Pulsing rate	t _{max}	p _{max}
SFL-1220 R10	1.4305/Vectra	G 3/8 female	0.5-20	6100 pulses/litre	-20...+90 °C	250 bar
SFL-1320 R10	PVDF/Vectra	G 3/8 male	0.5-20	5400...6100 pulses/litre	-20...+90 °C	16 bar

12. Maintenance

Assumed that the medium to be measured is not polluted, the SFL unit is maintenance-free. To avoid problems, we recommend the mounting of a filter, such as magnetic filter, model MF-R.

13. Dimensions

Model: SFL-1220 R10

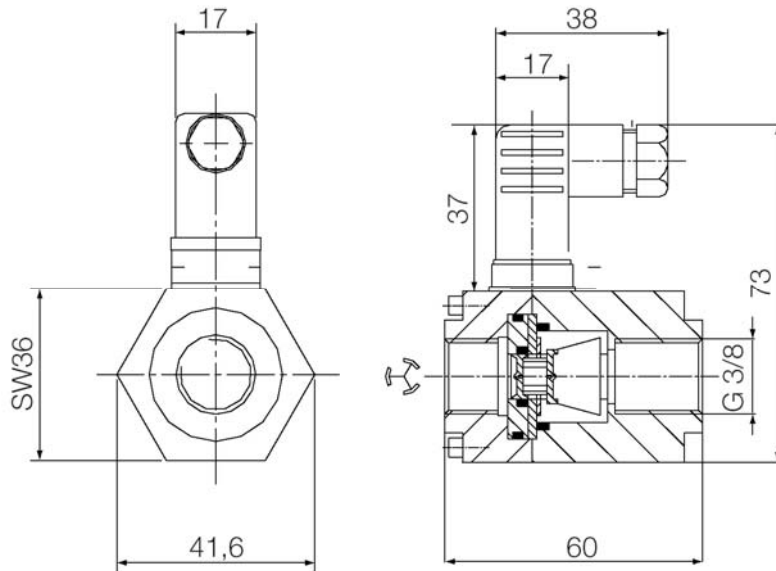

Model: SFL-1320 R10

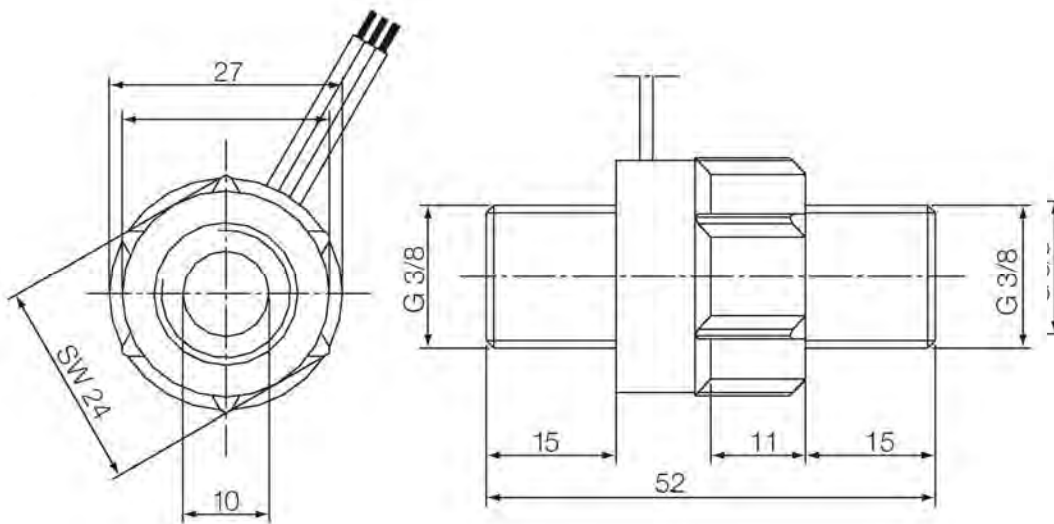

Dimensions: [mm]
Connections : [inch]

14. EU Declaration of Conformance

We, Kobold Messring GmbH, Hofheim-Ts, Germany, declare under our sole responsibility that the product:

Turbine Wheel Flow Meter Model: SFL

to which this declaration relates is in conformity with the EU directives noted below:

**1137/2008/EU
2009/137/EG
1025/2012/EU
2011/65/EU**

RoHS (category 9) industrial monitoring and control instruments, compliant, no CE-marking for the transitional period until 2017

Hofheim, 06. Dec. 2016

H. Peters
General Manager

M. Wenzel
Proxy Holder