



WATERFLUX 3070 Quick Start

Battery powered electromagnetic water meter

Electronic Revision ER 4.5.1_
(SW.REV 4.3.1_)

1	Safety instructions	4
<hr/>		
1.1	Instruction for transportation and handling of batteries.....	5
2	Installation	6
<hr/>		
2.1	Scope of delivery.....	6
2.2	Device description	7
2.3	Nameplate (example)	8
2.4	Storage	9
2.5	Transport	9
2.6	Pre-installation requirements	9
2.7	General requirements	10
2.7.1	Vibration	10
2.7.2	Magnetic field.....	10
2.8	Installation conditions	11
2.8.1	Inlet and outlet	11
2.8.2	T-section	11
2.8.3	Bends	12
2.8.4	Open feed or discharge.....	13
2.8.5	Pump	13
2.8.6	Control valve	13
2.8.7	Air venting and vacuum forces	14
2.8.8	Mounting position and flange deviation.....	15
2.8.9	IP68 Installation in a metering pit and subsurface applications	16
2.9	Mounting	17
2.9.1	Torques and pressures.....	17
2.10	Mounting of the signal converter	20
2.10.1	IP67 housing, remote version	20
2.10.2	Closing of the converter housing.....	20
3	Electrical connections	21
<hr/>		
3.1	Safety instructions.....	21
3.2	Grounding	21
3.3	Connection of the signal cable WSC	22
3.3.1	IP 67 housing (field version).....	22
3.4	Connection of the output cable	24
3.4.1	IP67 housing (compact and field version).....	24
3.4.2	IP68 housing (compact version).....	25
4	Start-up	26
<hr/>		
4.1	Connecting the internal battery	26
4.2	Connecting the external battery.....	27
4.2.1	IP67 housing (compact and field version).....	27
4.2.2	IP68 housing (compact version).....	27
4.2.3	Battery settings.....	27

5 Technical data	29
<hr/>	
5.1 Dimensions and weights	29
6 Notes	31
<hr/>	

Warnings and symbols used**DANGER!**

This information refers to the immediate danger when working with electricity.

**DANGER!**

These warnings must be observed without fail. Even partial disregard of this warning can lead to serious health problems and even death. There is also the risk of seriously damaging the device or parts of the operator's plant.

**WARNING!**

Disregarding this safety warning, even if only in part, poses the risk of serious health problems. There is also the risk of damaging the device or parts of the operator's plant.

**CAUTION!**

Disregarding these instructions can result in damage to the device or to parts of the operator's plant.

**INFORMATION!**

These instructions contain important information for the handling of the device.

**HANDLING**

- This symbol designates all instructions for actions to be carried out by the operator in the specified sequence.

RESULT

This symbol refers to all important consequences of the previous actions.

Safety instructions for the operator**CAUTION!**

Installation, assembly, start-up and maintenance may only be performed by appropriately trained personnel. The regional occupational health and safety directives must always be observed.

**LEGAL NOTICE!**

The responsibility as to the suitability and intended use of this device rests solely with the user. The supplier assumes no responsibility in the event of improper use by the customer. Improper installation and operation may lead to loss of warranty. In addition, the "Terms and Conditions of Sale" apply which form the basis of the purchase contract.

**INFORMATION!**

- *Further information can be found on the supplied CD-ROM in the manual, on the data sheet, in special manuals, certificates and on the manufacturer's website.*
- *If you need to return the device to the manufacturer or supplier, please fill out the form contained on the CD-ROM and send it with the device. Unfortunately, the manufacturer cannot repair or inspect the device without the completed form.*

1.1 Instruction for transportation and handling of batteries

**WARNING!**

Lithium batteries are primary power sources with high energy content. If mistreated, they may present a potential risk.

**INFORMATION!**

*The lithium batteries supplied, are **non-rechargeable**. Do NOT recharge the empty lithium batteries. Dispose of them according to the local legislation in your country.*

**INFORMATION!**

The manufacturer assumes no liability for customer failure.

Please observe the following instructions:

- Transport only in special packaging with special labels and transportation documents.
- Do not short-circuit, recharge, overcharge or connect with false polarity.
- Do not expose to temperature beyond the specified temperature range or incinerate the battery.
- Do not crush, puncture or open cells or disassemble battery packs.
- Do not weld or solder to the body of the battery.
- Do not expose contents of battery to water.
- Remove the battery from device before returning to the manufacturer for service or warranty reasons.
- Dispose battery packs in accordance with local regulations; where possible, recycle used batteries.

2.1 Scope of delivery



INFORMATION!

Do a check of the packing list to make sure that you have all the elements given in the order.



INFORMATION!

Inspect the packaging carefully for damages or signs of rough handling. Report damage to the carrier and to the local office of the manufacturer.



INFORMATION!

The remote version will arrive in two cartons. One carton contains the converter and one carton contains the sensor.

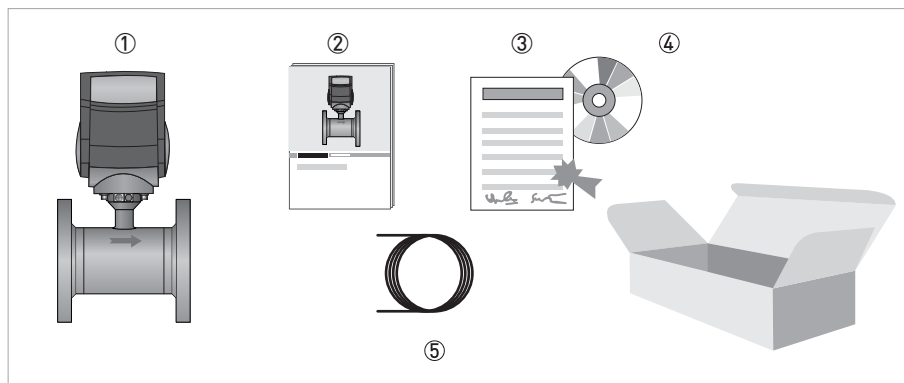

Figure 2-1: Scope of delivery

- ① Ordered water meter (compact or remote version)
- ② Product documentation
- ③ Factory calibration report
- ④ CD-ROM with product documentation in available languages
- ⑤ Signal cable (remote versions only)



INFORMATION!

Assembly materials and tools are not part of the delivery. Use the assembly materials and tools in compliance with the applicable occupational health and safety directives.



INFORMATION!

Special cable and/or cable assemblies are delivered according the ordered converter type.

2.2 Device description

Your measuring device is supplied ready for operation. The factory settings for the operating data have been made in accordance with your order specifications.



INFORMATION!

Product specific information and extensive product specification is available using PICK, the Product Information Center KROHNE web-tool.



PICK can be found via the service menu button on the KROHNE.com website.

The following versions are available:

- Compact version (the signal converter is mounted directly on the measuring sensor) in aluminium (IP67) or polycarbonate (IP68) housing
- Remote version (measuring sensor with connection box and a signal converter in a remote housing)

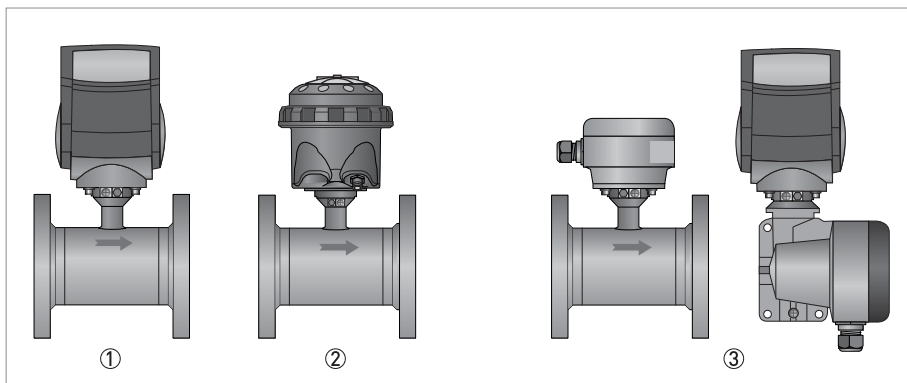

Figure 2-2: Device versions

- ① Compact version in aluminium (IP67) housing
- ② Compact version in polycarbonate (IP68) housing
- ③ Remote version

2.3 Nameplate (example)



INFORMATION!

Check the device nameplate to ensure that the device is delivered according to your order.

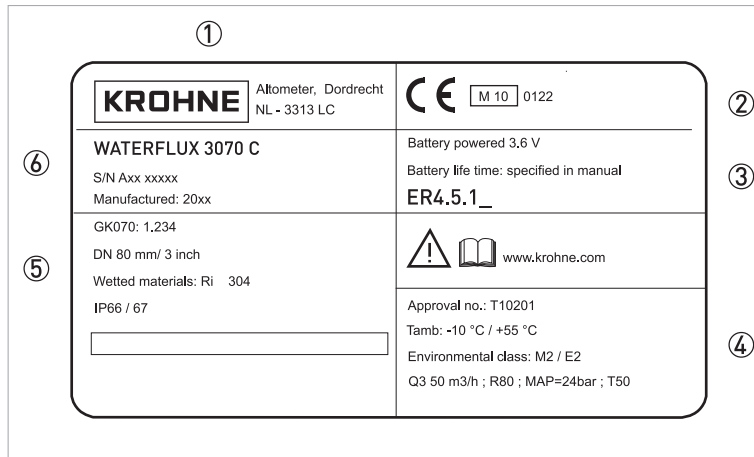

Figure 2-3: Example of nameplate

- ① Name and address of the manufacturer
- ② CE sign with number(s) of notified body / bodies
- ③ Battery voltage and Electronic Revision number
- ④ Optional (MI-001): Additional information including approval number, Q3, ratio
- ⑤ Meter constant, diameter, wetted materials, protection class
- ⑥ Type designation of the flowmeter, serial number, date of manufacturing

2.4 Storage

- Store the device in a dry and dust-free location.
- Avoid lasting direct exposure to the sun.
- Store the device in its original packaging.
- Storage temperature: -30...+70°C / -22...+158°F

2.5 Transport

Signal converter

- No special requirements.

Compact version

- Do not lift the device by the signal converter housing.
- Do not use lifting chains.
- To transport flange devices, use lifting straps. Wrap these around both process connections.

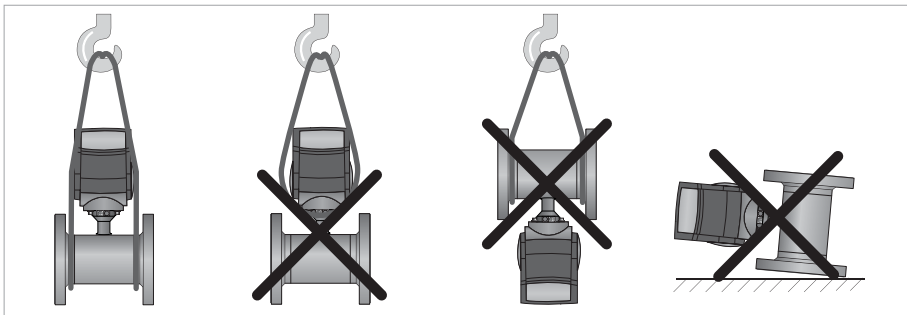

Figure 2-4: Transport

2.6 Pre-installation requirements

Make sure that you have all necessary tools available:

- Allen key (4 mm)
- Small screwdriver
- Wrench for cable glands
- Wrench for wall mounting bracket (remote version only)
- Torque wrench for installing flowmeter in pipeline

2.7 General requirements



INFORMATION!

The following precautions must be taken to ensure reliable installation.

- Make sure that there is adequate space to the sides.
- Protect the signal converter from direct sunlight and install a sun shade if necessary.
- Signal converters installed in control cabinets require adequate cooling, e.g. by fan or heat exchanger.
- Do not expose the signal converter to intense vibration. The flowmeters are tested for a vibration level in accordance with IEC 68-2-64.

2.7.1 Vibration

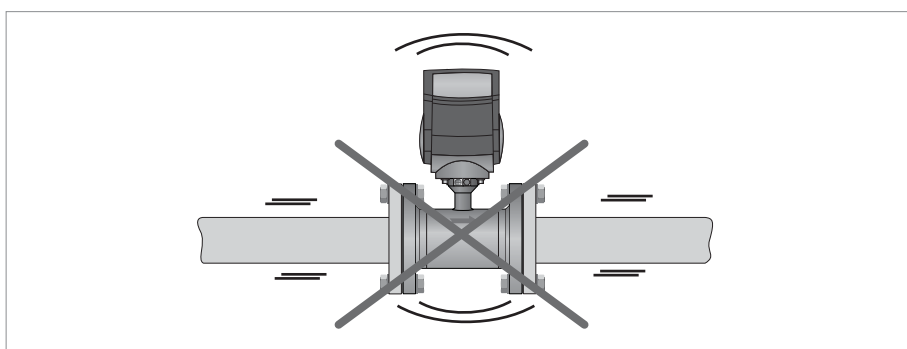

Figure 2-5: Avoid vibrations

2.7.2 Magnetic field

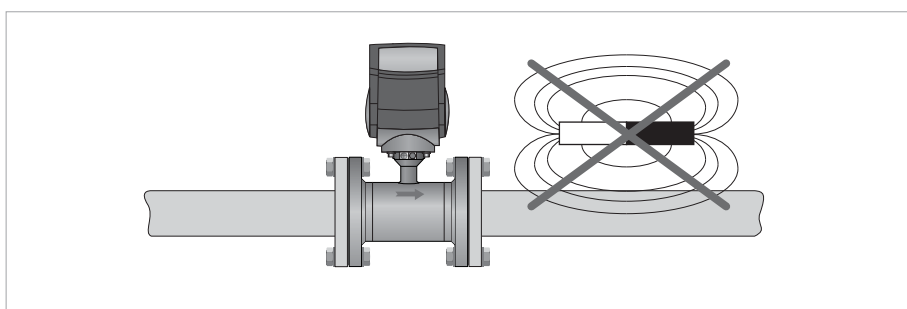

Figure 2-6: Avoid magnetic fields

2.8 Installation conditions



CAUTION!

To prevent damage to the Rilsan® coating, the WATERFLUX 3000 sensor must be installed carefully. Take precautions during transport and installation to protect the in- and outlet of the sensor.

2.8.1 Inlet and outlet

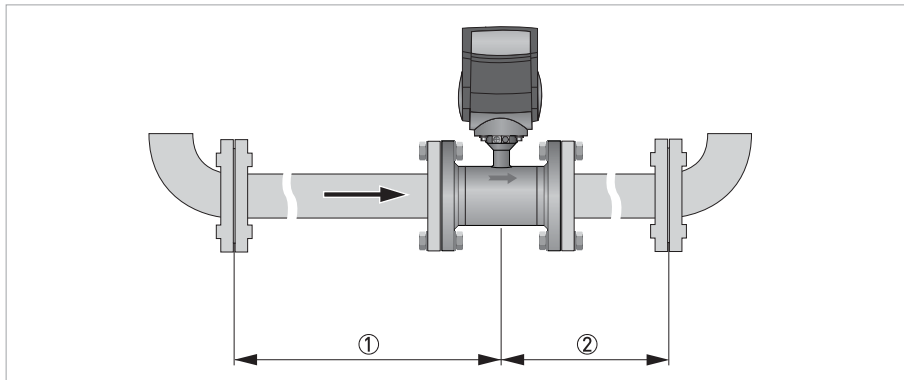

Figure 2-7: Minimal inlet and outlet

- ① Inlet: ≥ 0 DN
- ② Outlet: ≥ 0 DN

2.8.2 T-section

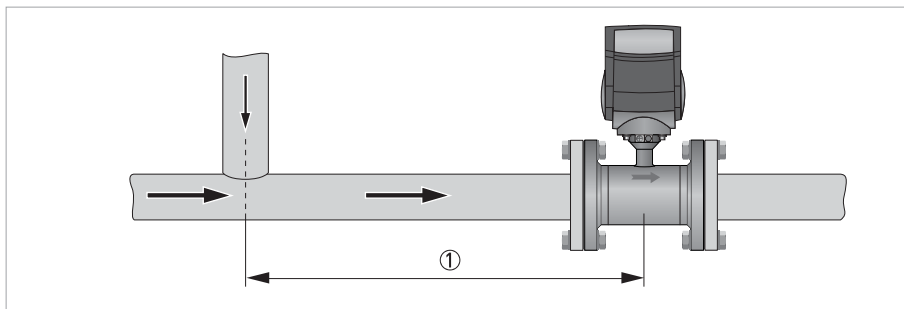

Figure 2-8: Distance behind a T-section

- ① ≥ 0 DN

2.8.3 Bends

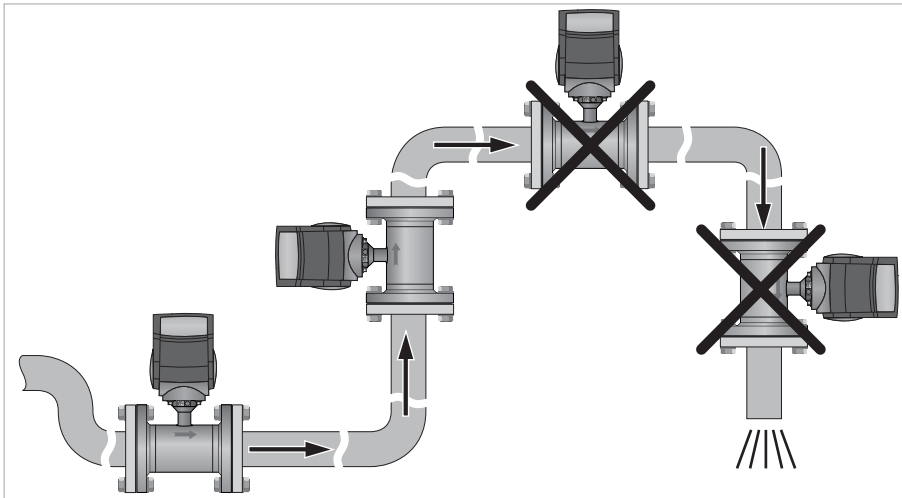

Figure 2-9: Installation in bending pipes

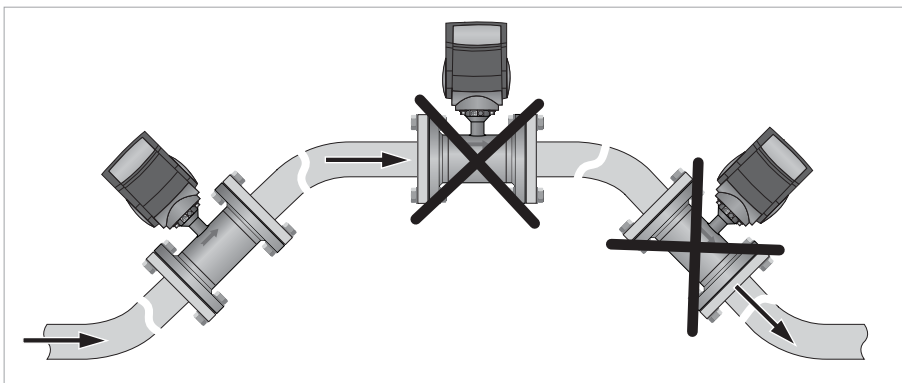

Figure 2-10: Installation in bending pipes



CAUTION!
 Avoid draining or partial filling of the flow sensor

2.8.4 Open feed or discharge

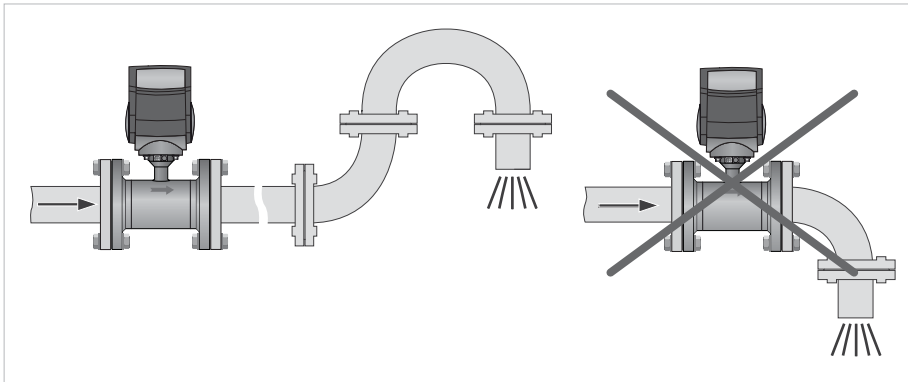

Figure 2-11: Installation in front of an open discharge

2.8.5 Pump

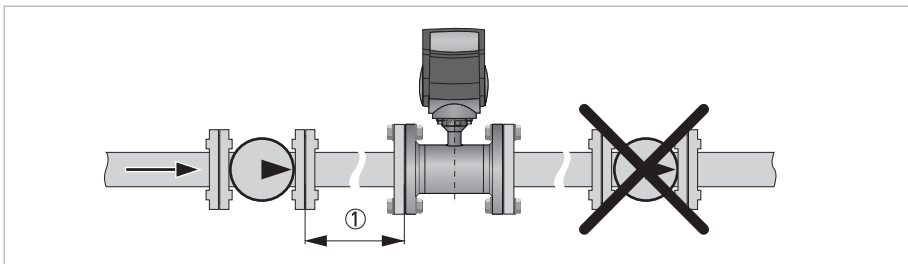

Figure 2-12: Recommended installation: behind a pump

① Inlet: ≥ 3 DN

2.8.6 Control valve

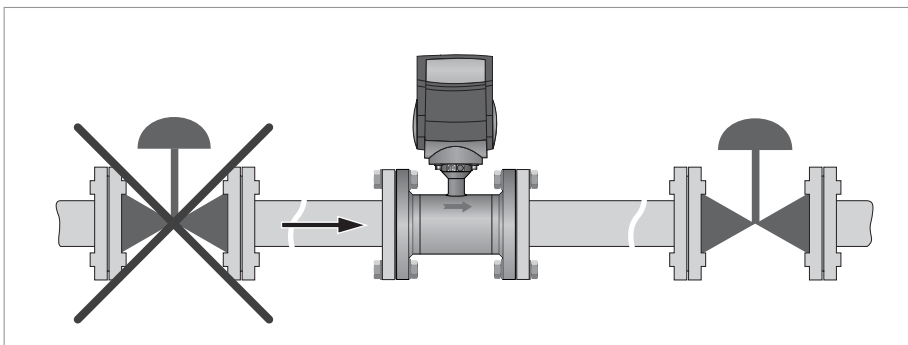

Figure 2-13: Recommended installation: in front of a control valve

2.8.7 Air venting and vacuum forces

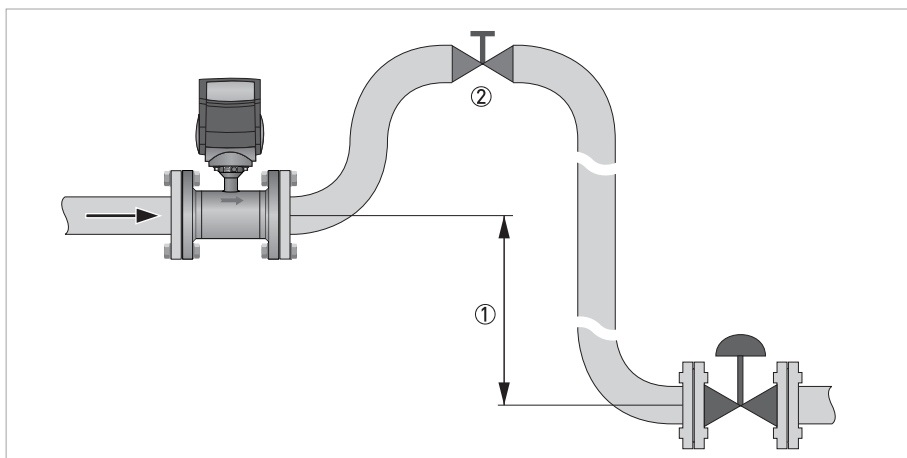

Figure 2-14: Air venting

- ① ≥ 5 m
- ② Air ventilation point

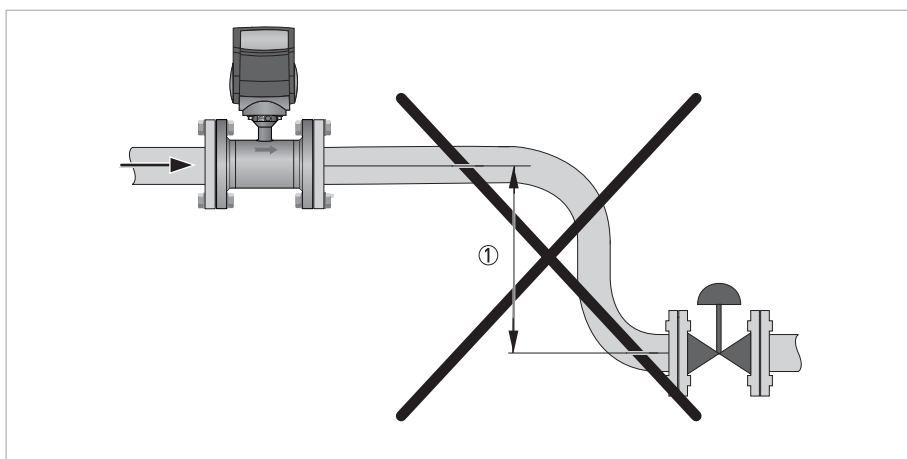

Figure 2-15: Vacuum

- ① ≥ 5 m

2.8.8 Mounting position and flange deviation

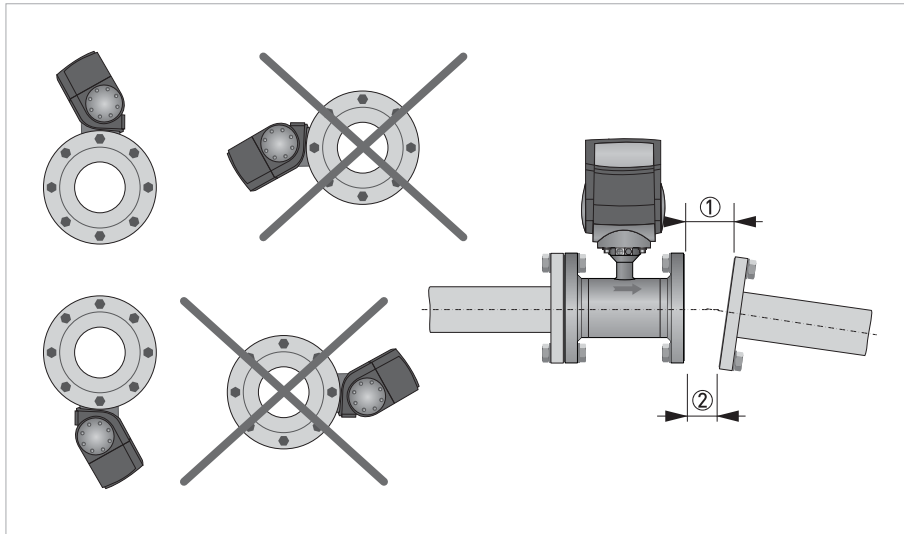

Figure 2-16: Mounting position and flange deviation

- ① L_{max}
- ② L_{min}

- Mount flow sensor either with signal converter aligned upwards or downwards.
- Install flow sensor in line with the pipe axis.
- Pipe flange faces must be parallel to each other.



CAUTION!

Max. permissible deviation of pipe flange faces: $L_{max} - L_{min} \leq 0.5 \text{ mm} / 0.02''$.



CAUTION!

Use the proper tools to ensure the integrity of the meter and prevent damage to the Rilsan® coating.

2.8.9 IP68 Installation in a metering pit and subsurface applications

The WATERFLUX 3000 flow sensor is optionally IP68 rated (NEMA 4X/6P) to IEC60529. It is suitable for submersion in flooded measurement chambers and for subsurface installation. Submersion of the sensor under water is possible down to a depth of 10 meters.

The compact IFC 070 signal converter is available in:

- an aluminum housing suitable for IP66/67, NEMA 4/4X/6
- a polycarbonate housing suitable for IP68, NEMA 4/4X/6.

This version is suitable for periodic submersion in flooded measurement chambers. The output cable has IP68 rated connectors.

In applications with prolonged or continuous submersion, it is advised to use the WATERFLUX 3070 remote version. The remote IFC 070 signal converter and GPRS data logger unit can be installed on the wall of the measuring pit near the lid for visual read out of the display.

The remote (field version) IFC 070 signal converter is available in:

- an aluminum housing suitable for IP66/67, NEMA 4/4X/6.

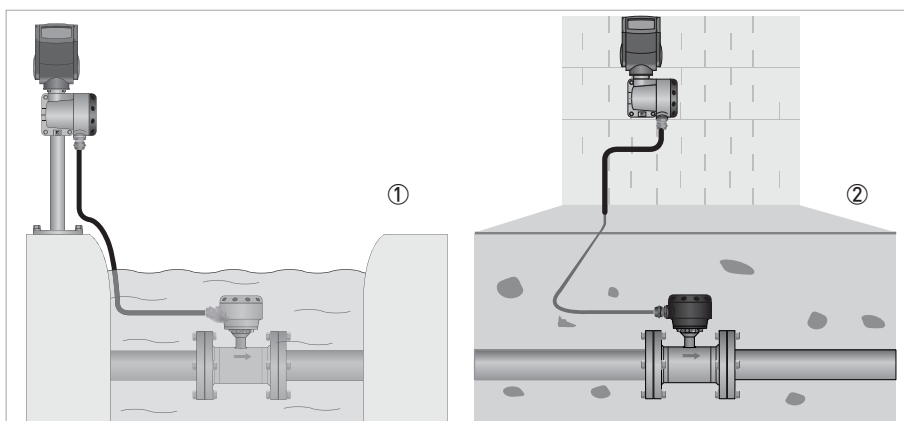

Figure 2-17: IP68 versions

- ① Submersible
- ② Buried

Note: figures shows a cable ≤ 25 m / 82 ft

2.9 Mounting

2.9.1 Torques and pressures

The maximum pressure and torque values for the flowmeter are theoretical and calculated for optimum conditions and use with carbon steel flanges.

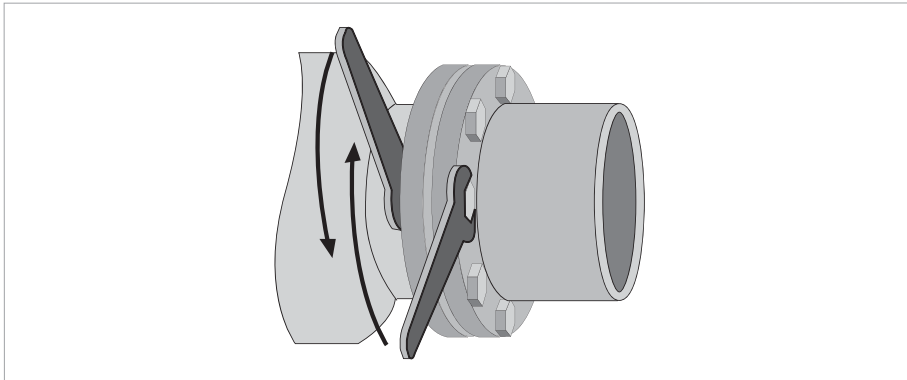

Figure 2-18: Tightening of bolts



Tightening of bolts

- Always tighten the bolts uniformly and in diagonally opposite sequence.
- Do not exceed the maximum torque value.
- Step 1: Apply approx. 50% of max. torque given in table.
- Step 2: Apply approx. 80% of max. torque given in table.
- Step 3: Apply 100% of max. torque given in table.

Nominal size DN [mm]	Pressure rating	Bolts	Max. torque [Nm] ^①
25	PN 16	4 x M 12	12
40	PN 16	4 x M 16	30
50	PN 16	4 x M 16	36
65	PN 16	8 x M 16	50
80	PN 16	8 x M 16	30
100	PN 16	8 x M 16	32
125	PN 16	8 x M 16	40
150	PN 10	8 x M 20	55
150	PN 16	8 x M 20	55
200	PN 10	8 x M 20	85
200	PN 16	12 x M 20	57
250	PN 10	12 x M 20	80
250	PN 16	12 x M 24	100
300	PN 10	12 x M 20	95
300	PN 16	12 x M 24	136
350	PN 10	16 x M 20	96
400	PN 10	16 x M 24	130
450	PN 10	20 x M 24	116
500	PN 10	20 x M 24	134
600	PN 10	20 x M 27	173

① The torque values also depend on variables (temperature, bolt material, gasket material, lubricants, etc.) outside the control of the manufacturer. Therefore these values should be regarded as indicative only.

Nominal size [inch]	Flange class [lb]	Bolts	Max. torque [lbs.ft] ^①
1	150	4 x 1/2"	4
1½	150	4 x 1/2"	11
2	150	4 x 5/8"	18
2.5	150	8 x 5/8"	27
3	150	4 x 5/8"	33
4	150	8 x 5/8"	22
5	150	8 x 3/4"	33
6	150	8 x 3/4"	48
8	150	8 x 3/4"	66
10	150	12 x 7/8"	74
12	150	12 x 7/8"	106
14	150 ②	12 x 1"	87
16	150 ②	16 x 1"	84
18	150 ②	16 x 1 1/8"	131
20	150 ②	20 x 1 1/8"	118
24	150 ②	20 x 1 1/4"	166

① The torque values also depend on variables (temperature, bolt material, gasket material, lubricants, etc.) outside the control of the manufacturer. Therefore these values should be regarded as indicative only.

② No full rating (max. 150 psi / 10 bar).

2.10 Mounting of the signal converter



INFORMATION!

Assembly materials and tools are not part of the delivery. Use the assembly materials and tools in compliance with the applicable occupational health and safety directives.

2.10.1 IP67 housing, remote version

Pipe mounting

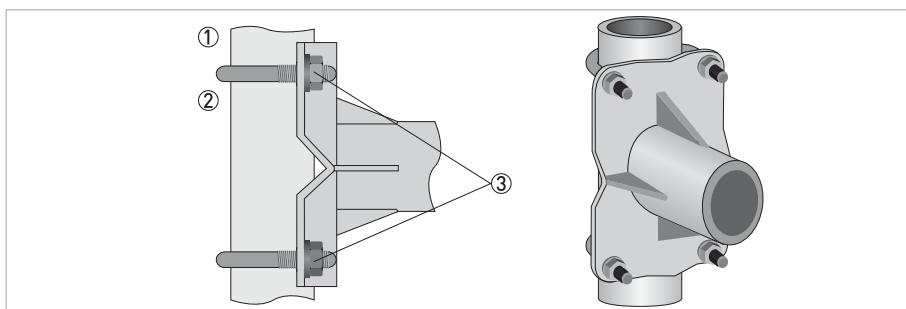

Figure 2-19: Pipe mounting of the field housing



- ① Fix the signal converter to the pipe.
- ② Fasten the signal converter using standard U-bolts and washers.
- ③ Tighten the nuts.

Wall mounting: no special requirements.

2.10.2 Closing of the converter housing

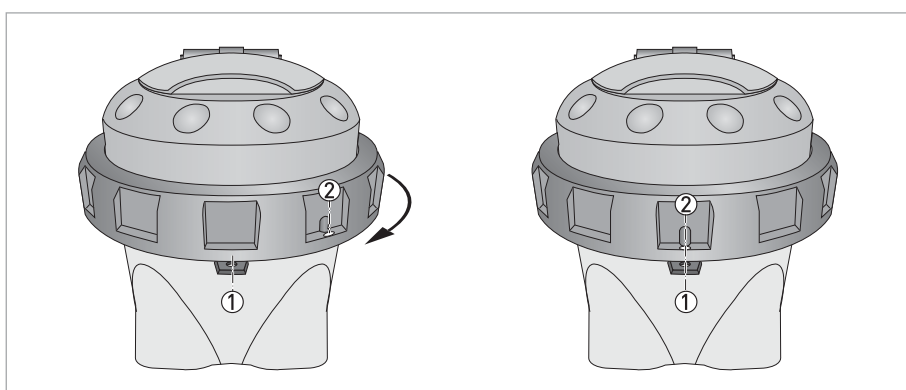

Figure 2-20: Closing of the converter housing



- Before closing the case of the converter, ensure that all surfaces in contact with the seals are clean.
- Position the upper part of the case and tighten the lock ring, up until the positions of points ① and ② are in line (do not tighten the ring any further).
- Use the special wrench to tighten the ring as advised above.

3.1 Safety instructions

**DANGER!**

All work on the electrical connections may only be carried out with the power disconnected. Take note of the voltage data on the nameplate!

**DANGER!**

Observe the national regulations for electrical installations!

**WARNING!**

Observe without fail the local occupational health and safety regulations. Any work done on the electrical components of the measuring device may only be carried out by properly trained specialists.

**INFORMATION!**

Look at the device nameplate to ensure that the device is delivered according to your order. Check for the correct supply voltage printed on the nameplate.

3.2 Grounding

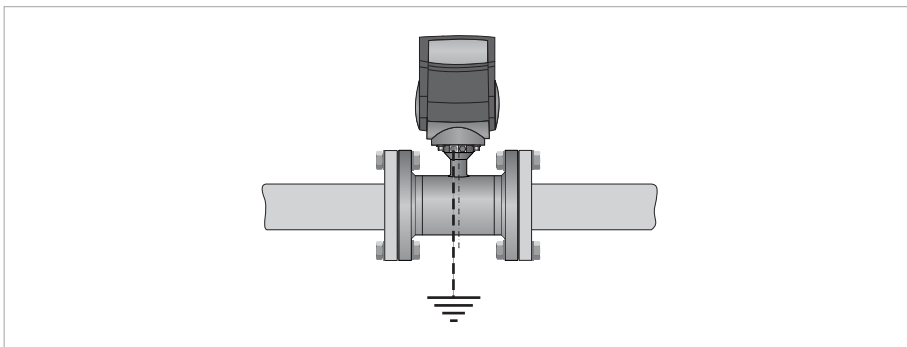

Figure 3-1: Grounding

**INFORMATION!**

Grounding without grounding rings. The flow sensor is equipped with a reference electrode.

3.3 Connection of the signal cable WSC

3.3.1 IP 67 housing (field version)



CAUTION!

To ensure smooth functioning, always use the signal cables included in the delivery.



INFORMATION!

The signal cable is only used for remote versions. The standard WSC-cable with max length of 25 m / 82 ft, includes both electrode and field current leads. Other lengths on request

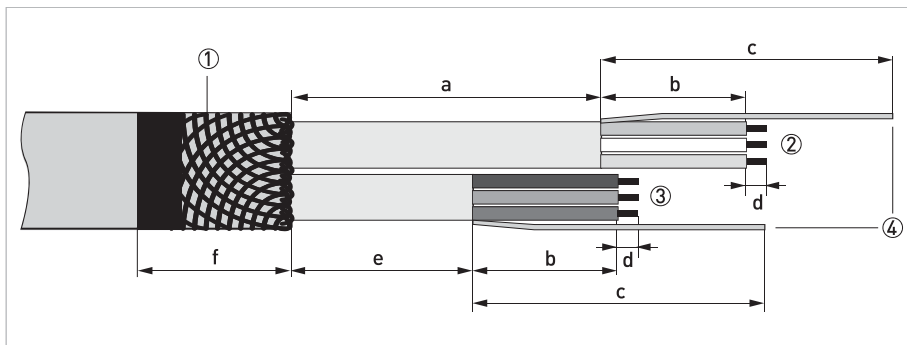

Figure 3-2: Preparation of standard cable on sensor side

- ① Shielding
- ② Blue + green + yellow cable, used for field current (terminals 7, 8, 9)
- ③ Brown + white + violet cable, used for electrode signals (terminals 1, 2, 3)
- ④ Drain wires

Dimensions of cable

	a	b	c	d	e	f
mm	75	35	70	5	45	30
inch	3.0	1.4	2.8	0.2	1.8	1.2

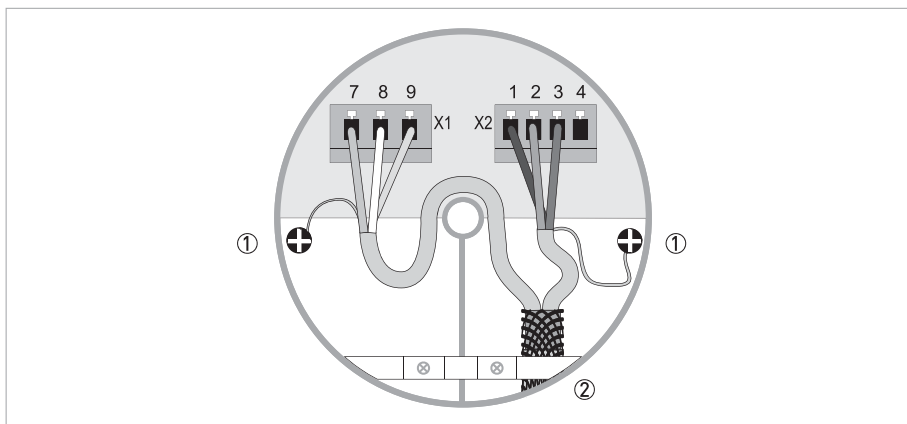

Figure 3-3: Cable connection at sensor side, standard cable

- ① Connect drain wires under screw
- ② Connect shielding under clamp

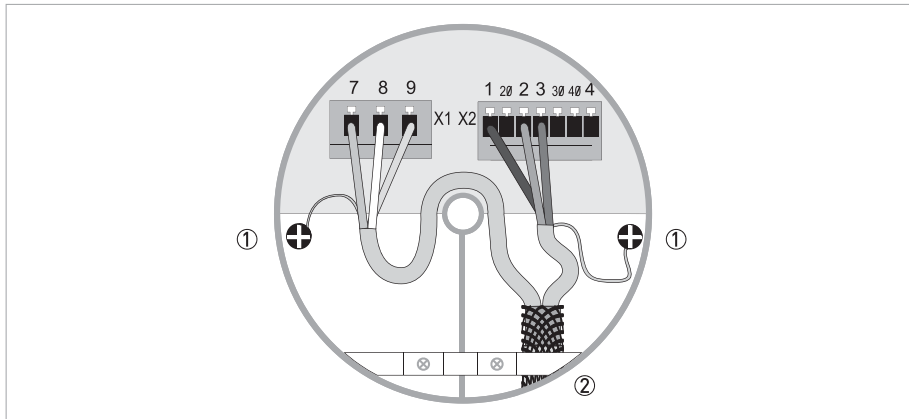

Figure 3-4: Cable connection at converter side, standard cable

- ① Connect drain wires under screw
- ② Connect shielding under clamp



- Prepare appropriate cable lengths as shown.
- Connect the wires as shown in the following table.

Wire color	Terminal	Function
Brown	1	Reference electrode
White	2	Standard electrode signal
Violet	3	Standard electrode signal
Blue	7	Field current
Green	8	Field current
Yellow	9	No function
Drain wires	Screws	Shielding

3.4 Connection of the output cable

3.4.1 IP67 housing (compact and field version)

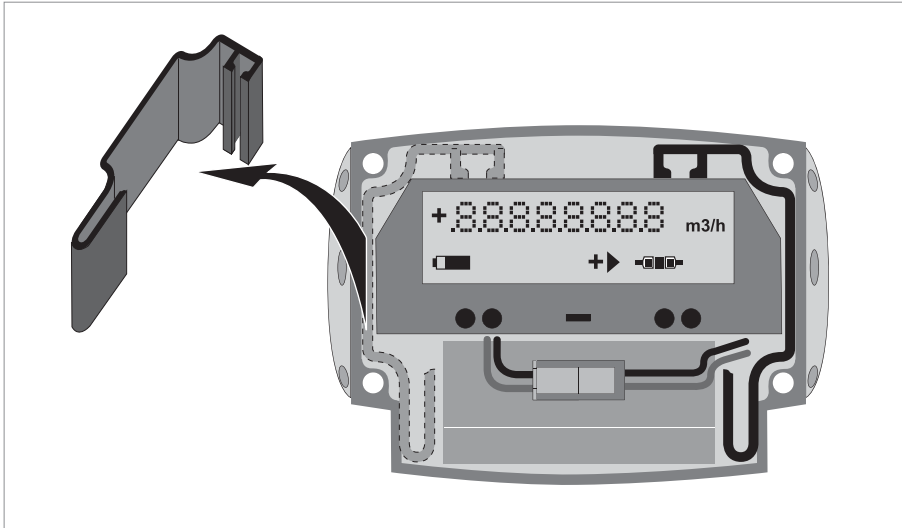

Figure 3-5: Removing side cap

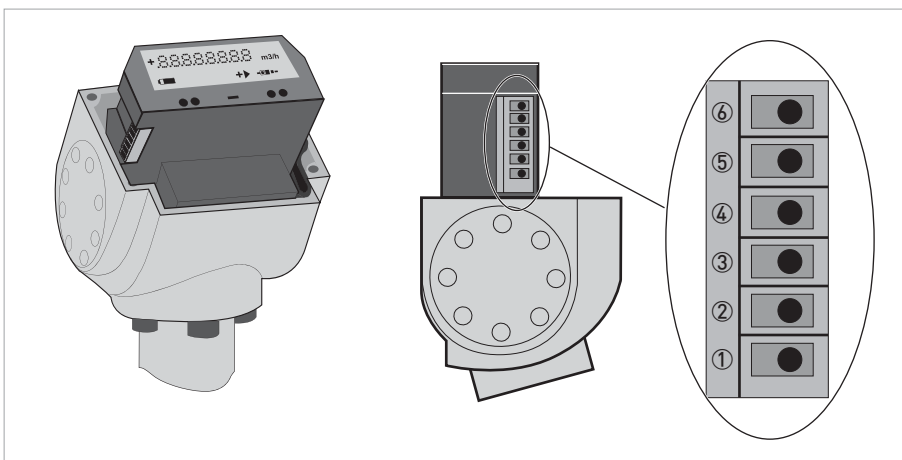

Figure 3-6: Terminal assignment

- ① Status output 1 or pulse output C
- ② Status output 2
- ③ Not used
- ④ Common ground
- ⑤ Pulse output A
- ⑥ Pulse output B

Electrical values

- **Pulse output passive:**
 $f \leq 100 \text{ Hz}$; $I \leq 10 \text{ mA}$; $U: 2.7 \dots 24 \text{ VDC}$ ($P \leq 100 \text{ mW}$)
- **Status output passive:**
 $I \leq 10 \text{ mA}$; $U: 2.7 \dots 24 \text{ VDC}$ ($P \leq 100 \text{ mW}$)

3.4.2 IP68 housing (compact version)

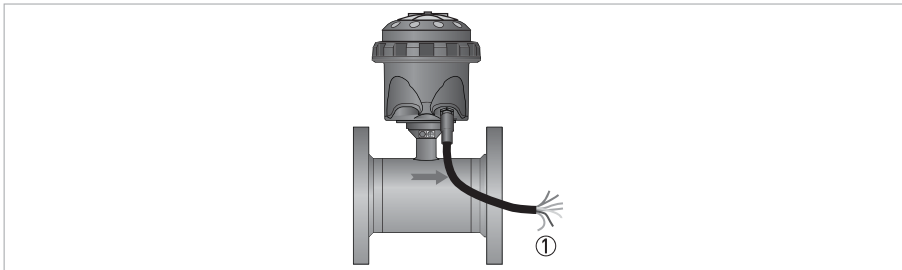

Figure 3-7: Output cable at IP68 compact version

① Color coded leads of the output cable

If an output is activated, the output cable with the IP68 rated connector has the following color coded leads:

Pulse output cable

Wire color	Contact on connector	Function
Yellow	A	Status output 1
White	G	Status output 2
Blue	H	Ground
Brown	B	Pulse output A
Green	F	Pulse output B
Pink	C	External battery +
Grey	E	External battery -

Note; with or without shielding

Note: See for the combined power and modbus / pulse cable options, next chapter.

Electrical values

- **Pulse output passive:**
 $f \leq 100 \text{ Hz}$; $I \leq 10 \text{ mA}$; $U: 2.7...24 \text{ VDC}$ ($P \leq 100 \text{ mW}$)
- **Status output passive:**
 $I \leq 10 \text{ mA}$; $U: 2.7...24 \text{ VDC}$ ($P \leq 100 \text{ mW}$)

4.1 Connecting the internal battery



CAUTION!

Please connect the battery before first use. The signal converter is delivered with a disconnected battery.



INFORMATION!

For transport purposes, signal converters which are verified to MI-001 or OIML R49 have also disconnected batteries. Please connect battery before placing the local utility seal.

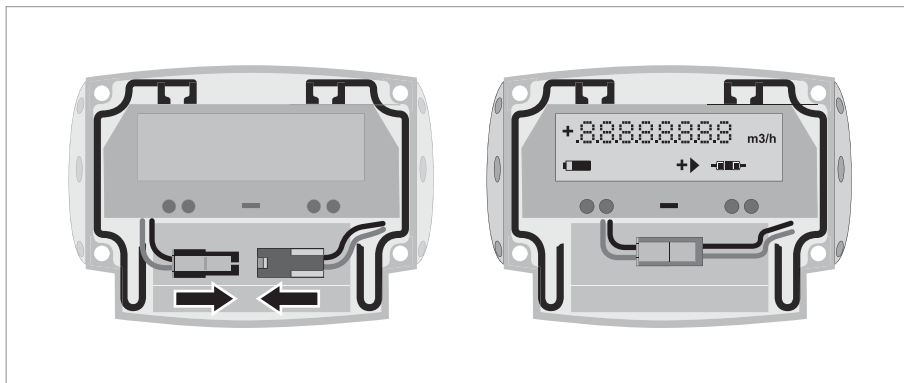

Figure 4-1: Connecting the battery



- Remove the protection cap and loosen the 4 Allen bolts (4 mm) (IP67 housing).
- Remove the cover.
- Fasten the battery connector of the power cable to the internal connector in the converter.
- Check if the display lights up.
- Put back the cover.



WARNING!

Make sure that the battery cable is not jammed by the cover.



- Tighten the 4 bolts and put back the protection cap (IP67 housing).
- For closing the case of the signal converter in the IP68 housing refer to *Closing of the converter housing* on page 20.



INFORMATION!

The device now operates with default menu settings. refer to *Battery settings* on page 27 for configuration of these menu settings.

4.2 Connecting the external battery

4.2.1 IP67 housing (compact and field version)



- Remove the protection cap and loosen the 4 Allen bolts (4mm).
- Remove the cover.
- Remove one of the blind cable glands in the bottom of the converter housing.
- Remove the metal strip at the bottom of the housing (2 screws).
- Lead the cable of the external battery through the gland opening and mount the attached cable gland loosely.
- Pull the cable to the top of the electronics.
- Fasten the battery connector to the internal connector in the converter.
- Check if the display lights up.
- Refit the metal strip at the bottom of the housing.
- Tighten the cable gland.
- Put back the cover.

**WARNING!**

Make sure that the battery cable is not jammed by the cover.



- Tighten the 4 bolts and put back the protection cap (IP67 housing).
- For closing the case of the signal converter in the IP68 housing refer to *Closing of the converter housing* on page 20.

**INFORMATION!**

The device now operates with default menu settings.

*For configuration of these menu settings refer to *Battery settings* on page 27.*

4.2.2 IP68 housing (compact version)

The output cable has two color coded leads for connecting the external battery.

For detailed information refer to *IP68 housing (compact version)* on page 25.

4.2.3 Battery settings

After changing the battery:

- Reset the battery lifetime counter (Menu number B2)
- Select the battery type, if a different type of battery is used. (Menu number B0)
- Change the total battery capacity, if a different type of battery is used. (Menu number B1)

No.	Function	Options	Description
B0	Battery type	0 = No battery	A wrong setting influences the battery lifetime calculation.
		1 = One internal battery	
		2 = Two internal batteries	
		3 = External battery pack	
B1	Total battery capacity	xxx.xx = 019.00 (19.000 Ah)	Total of all batteries in Ah. After a change to a different battery type, change the setting (19 one battery, 38 two batteries, or 78 external battery)
B2	Reset battery lifetime counter	0 = Off	Set the value to 1 to reset the battery lifetime counter. After a reset, the menu setting automatically goes back to 0.
		1 = Reset	

5.1 Dimensions and weights

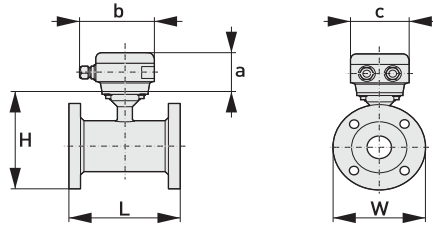
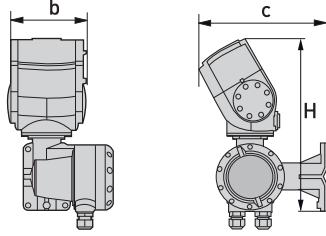
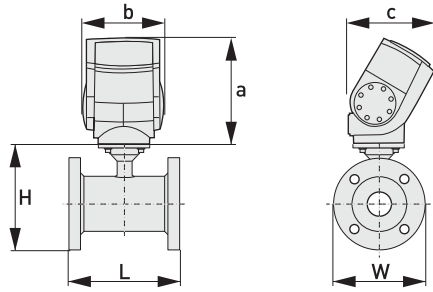
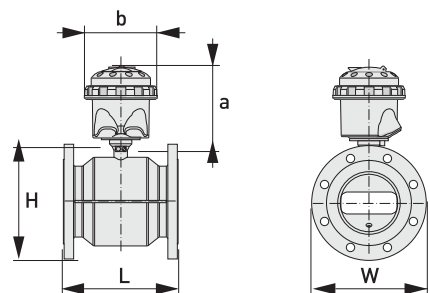
<p>Remote flow sensor</p>		<p>a = 88 mm / 3.5"</p> <p>b = 139 mm / 5.5" ①</p> <p>c = 106 mm / 4.2"</p> <p>Total height = H + a</p>
<p>Remote version in aluminum housing (IP67)</p>		<p>b = 132 mm / 5.2"</p> <p>c = 235 mm / 9.3"</p> <p>H = 310 mm / 12.2"</p> <p>Weight = 3.3 kg / 7.3 lb</p>
<p>Compact version in aluminum housing (IP67)</p>		<p>a = 170 mm / 6.7"</p> <p>b = 132 mm / 5.2"</p> <p>c = 140 mm / 5.5"</p> <p>Total height = H + a</p>
<p>Compact version in polycarbonate housing (IP68)</p>		<p>a = 159 mm / 6.3"</p> <p>b = 161 mm / 6.3"</p> <p>Total height = H + a</p>

① The value may vary depending on the used cable glands.



INFORMATION!

- All data given in the following tables are based on standard versions of the flow sensor only.
- Especially for smaller nominal sizes of the flow sensor, the signal converter can be bigger than the flow sensor.
- Note that for other pressure ratings than mentioned, the dimensions may be different.
- For full information on signal converter dimensions see relevant documentation.

EN 1092-1

Nominal size DN [mm]	Dimensions [mm]			Approx. weight [kg]
	L	H	W	
25	150	151	115	5
40	150	166	150	6
50	200	186	165	13
65	200	200	185	11
80	200	209	200	17
100	250	237	220	17
125	250	266	250	21
150	300	300	285	29
200	350	361	340	36
250	400	408	395	50
300	500	458	445	60
350	500	510	505	85
400	600	568	565	110
450	600	618	615	125
500	600	671	670	120
600	600	781	780	180

ASME B16.5 / 150 lb

Nominal size [inches]	Dimensions [inches]			Approx. weight [lb]
	L	H	W	
1	5.91	5.83	4.3	18
1½	5.91	6	4.9	21
2	7.87	7.05	5.9	34
3	7.87	8.03	7.5	42
4	9.84	9.49	9.0	56
5	9.84	10.55	10.0	65
6	11.81	11.69	11.0	80
8	13.78	14.25	13.5	100
10	15.75	16.3	16.0	148
12	19.7	18.8	19.0	210
14	27.6	20.7	21	290
16	31.5	22.9	23.5	370
18	31.5	24.7	25	420
20	31.5	27	27.5	500
24	31.5	31.4	32	680





KROHNE – Process instrumentation and measurement solutions

- Flow
- Level
- Temperature
- Pressure
- Process Analysis
- Services

Head Office KROHNE Messtechnik GmbH
Ludwig-Krohne-Str. 5
47058 Duisburg (Germany)
Tel.: +49 203 301 0
Fax: +49 203 301 10389
info@krohne.com

The current list of all KROHNE contacts and addresses can be found at:
www.krohne.com

KROHNE