



AP4151-2000

Action PAK® AP4151

RTD Input, Signal Conditioners

Provides a DC Output in Proportion to an RTD Input



- Direct RTD Input
- Integral Lead-Length Compensation
- Wide-ranging input and output
- Plug-in Installation
- Selectable 120/240VAC Input Power

Description

The AP4151-2000 is a wide-ranging, isolating signal conditioner for RTD inputs. The input is configurable for either 2- or 3-wire RTDs (2-wire requires a jumper wire across terminals 4 and 5 of the mounting base). The RTD types supported are Platinum, Nickel and Copper. Pushbutton ranging is used for adjusting the input and output ranges. The output can be set to be either linear to resistance or linear to temperature.

In most applications, the model AP4151-2000 can be used to replace previous models of AP4001 and AP4151.

Applications

The Action Pak model AP4151-2000 is useful in any application requiring a DC output from an RTD input. Typical applications include energy management and data acquisition of process temperatures. The output of the AP4151-2000 can drive a digital meter for direct display, or interface with a computer for monitoring and control.

Mounting

All Action Paks feature plug-in installation. The model AP4151-2000 uses an 8-pin base and either molded socket M008 or DIN socket MD08.

Dimensions

Dimensions are in millimeters (inches)

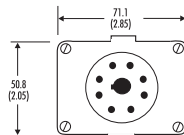
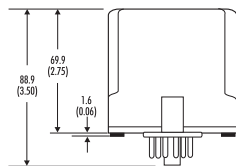

Mark III

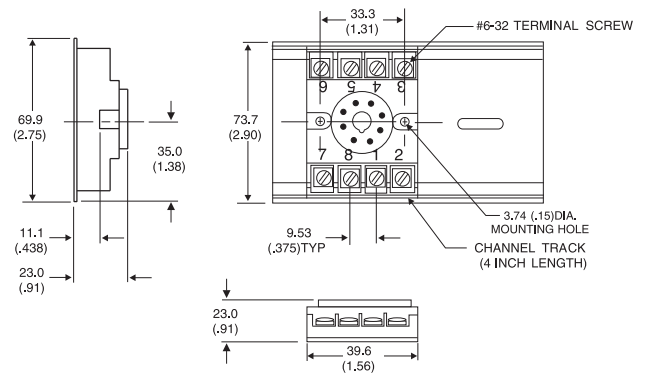

M008 (Track/Surface)

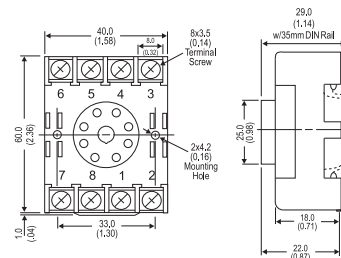

MD08 (DIN Rail)

Mounting

All Action Paks feature plug-in installation. The AP4151-2000 uses an 8-pin base, either the molded socket (M008) or the DIN rail socket (MD08). An optional retaining spring (M801) is available if required for the application.

Power Connections

Power is connected according to the table above. The unit supports either 115VAC input (the default) or 230VAC input. If you need 230VAC input, jumpers, located next to the input transformer on the base board, need to be changed according to the diagram below.

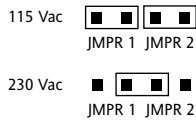

Diagnostic LEDs

Other than when executing the pushbutton calibration routine, the LEDs blink under the following conditions:

- GREEN:** 2 Hz when the input is under range 8 Hz when the input is over range
- RED:** 2 Hz when the output is under range 8 Hz when the output is over range

An Under Range condition exists when the signal is lower than the operational low value minus 6.25% of the operational span. An Over Range condition exists when the signal is higher than the operational high value plus 6.25% of the operational span.

A voltage output short circuit can cause an under range condition (RED blinking at a 2 Hz rate). A current output open circuit can cause an over range condition (RED blinking at an 8 Hz rate). There could be two or more LEDs blinking at the same time, which means the module has more than one error condition present. Only when all error conditions have been cleared will the LEDs return to their normal condition (Green ON, Red and Yellow OFF).

Calibration

For best results, calibration should be performed in the operating environment, allowing at least one hour warm-up for thermal stability of the system. If pre-calibration on a test bench is desired, an output load equal to the input impedance of the devices connected to the AP4151-2000 output is recommended, along with the warm-up period.

Note: Many applications do not require calibrating the output levels and simply utilize the default operational ranges of the unit (0-5VDC, 0-10VDC, 0-20mA or 4-20mA). If the factory default calibration has been changed, the last saved operational output values are utilized. In those applications, the only calibration required is the operational input values. Once the maximum and minimum input values have been set, the Green and Red LEDs will be on. At this point, simply press the CAL button rapidly 3 times and you will exit the calibration routine without effecting the last saved calibration for the operational output values.

1. Connect a resistance decade box (with 0.01 precision) to the input (Pins 5 and 6). Jumper pin 4 to pin 5. Connect the output to a voltage or current meter, depending on your application. Apply power and allow the system to reach thermal equilibrium.

2. Hold down the pushbutton switch for 4 seconds. The Yellow and Red LEDs should be on. Push the CAL button momentarily and the Yellow and Green LEDs will be on. (From this point on, you can exit the calibration procedure at any step without saving new data by holding the CAL button for at least 4 seconds.)

3. Set the resistance to the value that matches your desired maximum operational input temperature and push the CAL button. The Yellow LED should now be on.

4. Set the resistance to the value that matches your desired minimum operational input temperature and push the CAL button. The Green and Red LEDs should now be on. If you do not wish to change the output calibration, press the CAL button rapidly three times to exit the calibration routine.

5. If you do wish to do a custom operational range for the output, increase the resistance until the output is precisely at the desired maximum level (e.g. 20.00mA) and push the CAL button. The Red LED should be on.

6. Decrease the resistance until the output is precisely at the desired minimum level (e.g. 4.00mA) and push the CAL button. All three LEDs should now be on.

7. To finish calibration, push the button one final time. The calibration data is now saved. The Green LED should be on if the input is within the calibrated range.

Default Settings

- Input: Pt-100, 0-500°C
Output: 4-20mA

Table 1. Switch Settings

Function	SW1								SW2				
	1	2	3	4	5	6	7	8	1	2	3	4	5
RTD Type													
Pt100-385					■	■	■	■	■				
Pt200-385						■	■	■					■
Pt500-385					■		■	■		■			
Pt1000-385							■	■			■		
Pt100-3911					■	■			■				
Pt200-3911						■		■					■
Pt500-3911					■			■		■			
Pt1000-3911								■			■		
Pt100-392					■	■	■		■				
Pt200-392						■	■						■
Pt500-392					■		■			■			
Pt1000-392							■				■		
Ni100-618					■	■			■				
Ni120-672						■			■				
Cu9.035-427					■								■
No Linearization	■												
Output													
4-20mA													
0-20mA			■										
0-5V		■											
0-10V		■	■										
Reverse Out				■									

Key: ■ = ON or Closed

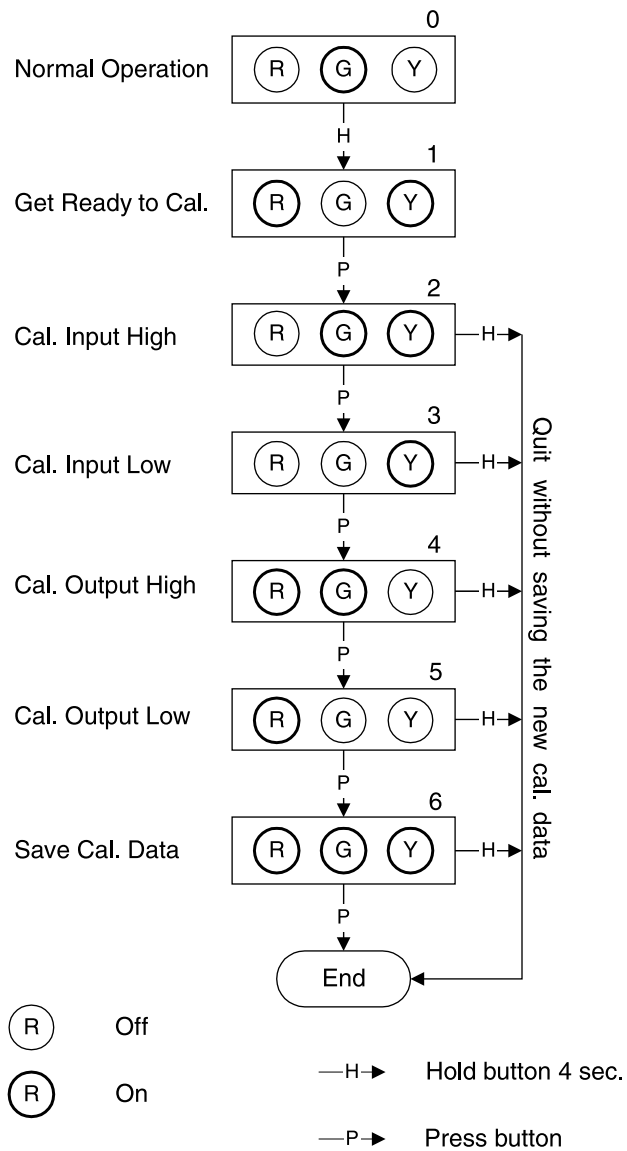

NOTE: If there is no data change from step 4 to 6, the output calibration data will remain unchanged

Figure 1. Calibration Flow Chart

Specifications

Leadwire effect:

<+/- 0.1% of max input temperature span, max.

Leadwire Resistance (Max Ohms/lead):

40% of RTD resistance

RTD Excitation Current:

< 25uA to 2.5mA depending upon RTD type

Operating Modes:

Direct:: increasing input produces increasing output

Reverse: increasing input produces decreasing output

Output Ranges:

0-20mA, 4-20mA, 0-5VDC, 0-10VDC (higher voltage to 15V @ 3mA drive)

Selectable between linear to temp or ohms

Turn-Up/Turn-Down:

75% (90% of span @ 0.5% linearity, 80% @ 0.15%)

Output Drive:

0-20mA, 4-20mA ranges: 15V compliance (750 ohm load maximum)

0-5V and 0-10V ranges: 10mA drive (1000 ohm load minimum)

Output Accuracy:

Current Outputs: ± 0.1% of full scale, max.

Voltage Outputs: ± 0.1% of full scale, max.

Stability:

+100ppm (±0.01%) of full scale / °C, typical

Adjustments:

Configuration: switch selectable input type, output range and linearization type
Pushbutton: Pushbutton zero and span from maximum to minimum specified in input range table.

Response Time:

250mSec typical, 300mSec maximum.

LED Indicator:

GREEN: RUN, on when unit is powered.

Flashes at a 2Hz rate when the input is under range by 6.25%

Flashes at an 8Hz rate when the input is over range by 6.25%

RED: OUTPUT, on while calibrating output.

Flashes at a 2Hz rate when the output is under range by 6.25%

Flashes at an 8Hz rate when the output is over range by 6.25%

YELLOW: INPUT, on while calibrating input

Power Requirements:

120/240VAC 50-400Hz, jumper selectable, 3W typical, 5W max.

Isolation:

1500VDC, Input to Output to Power

Environmental:

Operating Temperature:

0°C to +60°C (32 to 149°F)

Storage Temperature:

-20°C to 85°C (-4 to 185°F)

Operating Relative Humidity:

15% to 95% RHNC @ 45°C

Non-operating Relative Humidity:

90% RHNC @ 65°C for 24 Hrs.

Agency Approvals:

CSA C22.2, N0. 0-M91, 142-M1987

UL508, combined mark (pending)

Ordering Information

Specify:

1. Model: **AP4151-2000**

Accessories:

- M801-0000 Retaining Spring
- M008-A 8 pin Track Mount Socket
- M004-0000 4 ft Long Channel Track
- MD08-0000 8 pin DIN Mount Socket

Pin Connections

- 1 AC Power (Hot)
- 2 Shield (Gnd.)
- 3 AC Power (Neu.)
- 4 RTD Return
- 5 RTD Input (-)
- 6 RTD Input (+)
- 7 Output (+)
- 8 Output (-)

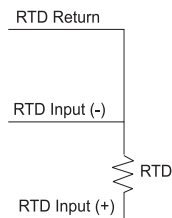

Table 1: AP4151 Input Limits

Input Type	Input Range	Minimum Recommended Span
Pt100 ohm, (0.00385, 0.003911, 0.00392)	-200 to +870° C	100° C
Pt200 ohm, (0.00385, 0.003911, 0.00392)	-200 to +870° C	100° C
Pt500 ohm, (0.00385, 0.003911, 0.00392)	-200 to +870° C	100° C
Pt1000 ohm, (0.00385, 0.003911, 0.00392)	-200 to +870° C	100° C
Ni100 ohm, (0.00618)	-100 to +320° C	50° C
Ni120 ohm, (0.00672)	-100 to +320° C	50° C
Cu9.035 ohm, (0.00472)	-200 to +260° C	50° C

Eurotherm®

by **Schneider Electric**

Schneider Electric Systems USA, Inc.

44621 Guilford Drive, Suite 100

Ashburn, VA 20147

703-724-7300

info.eurotherm.us@schneider-electric.com



Printed on recycled paper

www.eurotherm.com

Factory Assistance

For additional information on calibration, operation and installation contact our Technical Services Group:

703-724-7314

US.Support@schneider-electric.com

721-0853-00-F 09/06 Copyright© Eurotherm, Inc 2006