

USER'S GUIDE

Installation & Operation
Instructions

Area-Velocity Flow Meter

Model AVFM 5.0

Manual Series A.2.4

Note: This page has been left blank intentionally.

INDEX

CONNECTIONS 4
FUNCTION TEST 4
KEYPAD SYSTEM..... 6
CALIBRATION MENU 7
ICONS..... 8
MESSAGE ICON 9
STATUS..... 9
PASSWORD 10
UNITS/MODE 11
CALIBRATION..... 12
RELAY PARAMETERS 16
SPECIAL FUNCTIONS 17
INSTALLATION - SENSOR LOCATION 19
ENCLOSURE INSTALLATION 23
FIELD TROUBLESHOOTING..... 25
APPLICATIONS HOTLINE 27
PRODUCT RETURN PROCEDURE..... 27
AREA-VELOCITY FLOW DATA SHEET 28
APPENDIX A – OPTIONS..... 30
DATA LOGGING (OPTIONAL)..... 38
SPECIFICATIONS 40

IMPORTANT NOTE: This instrument is manufactured and calibrated to meet product specifications. Please read this manual carefully before installation and operation. Any unauthorized repairs or modifications may result in a suspension of the warranty.

Available in Adobe Acrobat pdf format

CONNECTIONS

POWER INPUT: 100 to 240 VAC 50/60Hz. No adjustments are necessary for voltages within this range. Connect L (Live) N (Neutral) and AC Ground.

Optional DC: 9-32 VDC. Connect to + and - terminals.

Optional Thermostat and Heater modules are available rated for 115 VAC or 230 VAC.

IMPORTANT NOTE: To comply with CSA/UL electrical safety standards, AC power input and relay connection wires must have conduit entry to the instrument enclosure. Installation requires a switch, overcurrent fuse or circuit breaker in the building (in close proximity to the equipment) that is marked as the disconnect switch.



Risk of electric shock. Loosen cover screw to access connections. Only qualified personnel should access connections.

Note: Use of instrumentation over 40°C ambient requires special field wiring.

Note: User replaceable fuse is 2 Amp 250V (T2AL250V).

FUNCTION TEST:

Connect the sensor to the sensor terminals as shown on next page, then apply power. Allow 30 seconds for the AVFM 5.0 to initialize.

- A. Place QZ02L sensor (flat to the bottom) in a bucket of water about 6" deep and select **Level** mode (from UNITS/MODE menu) to see a level reading.
- B. Select **Velocity** mode and stir the water to see a velocity reading.

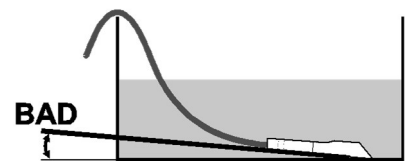
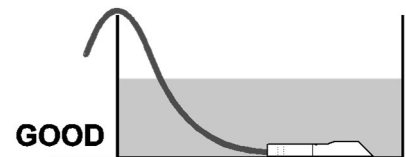

CONNECTIONS

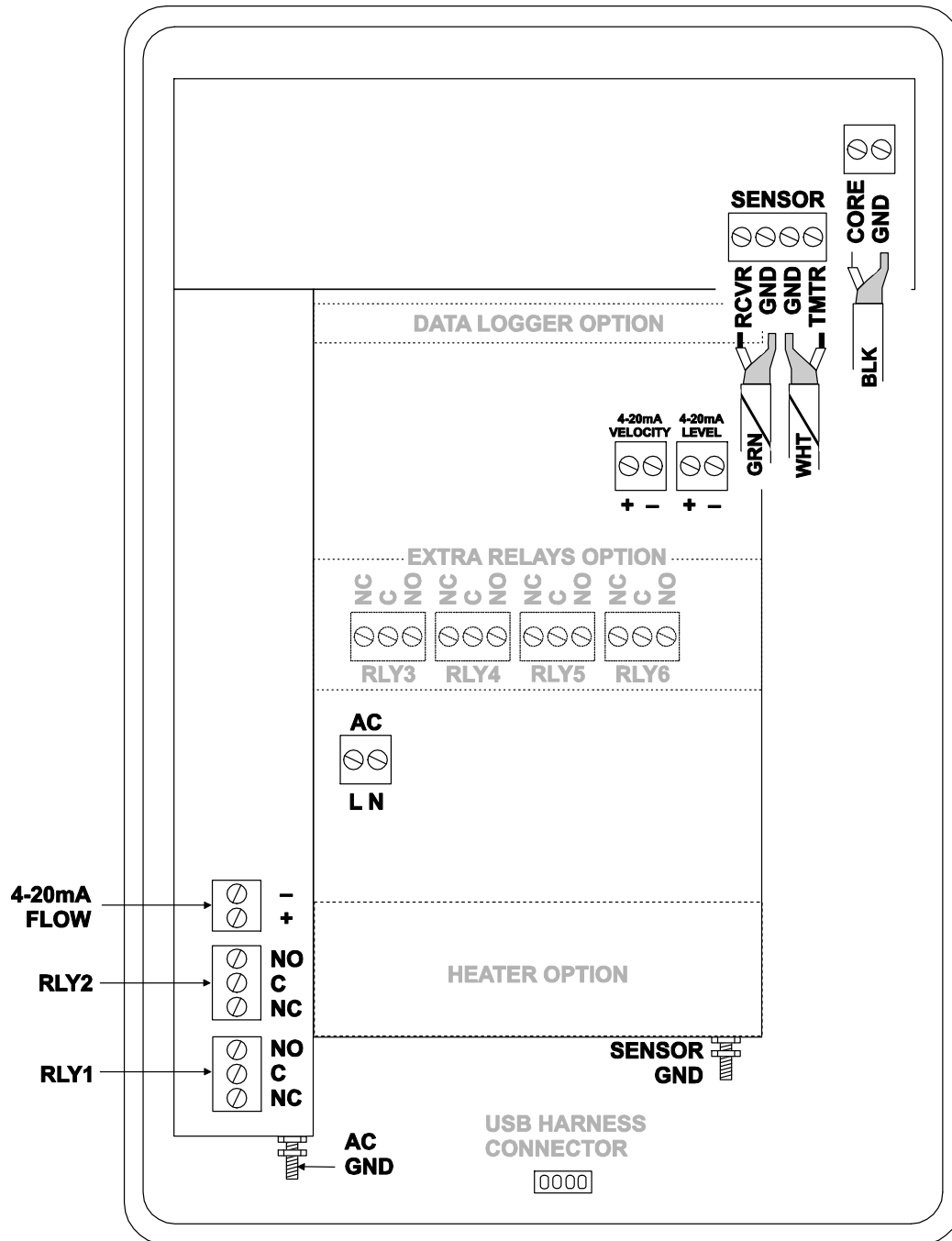

KEYPAD SYSTEM

The AVFM 5.0 uses a menu system. Arrows show the four directions to leave a menu box. Pressing a corresponding keypad arrow will move to the next item in the direction shown. Move the cursor (underline) under numerals and increase or decrease numerals with the **↑** and **↓** keys.

To store calibration values permanently (even through power interruptions), press **✓**.

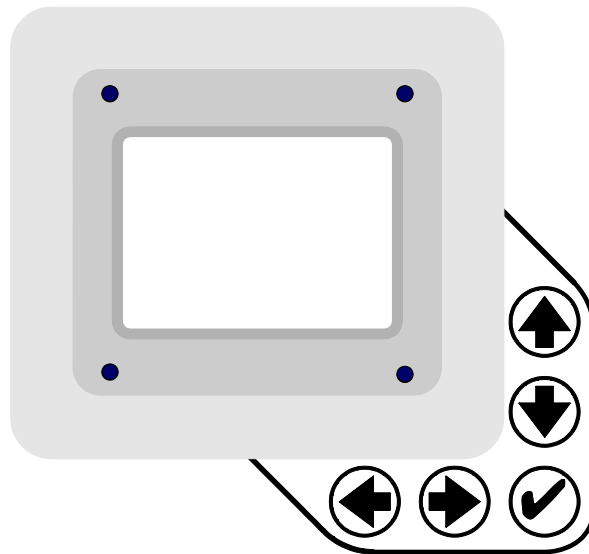

CALIBRATION MENU

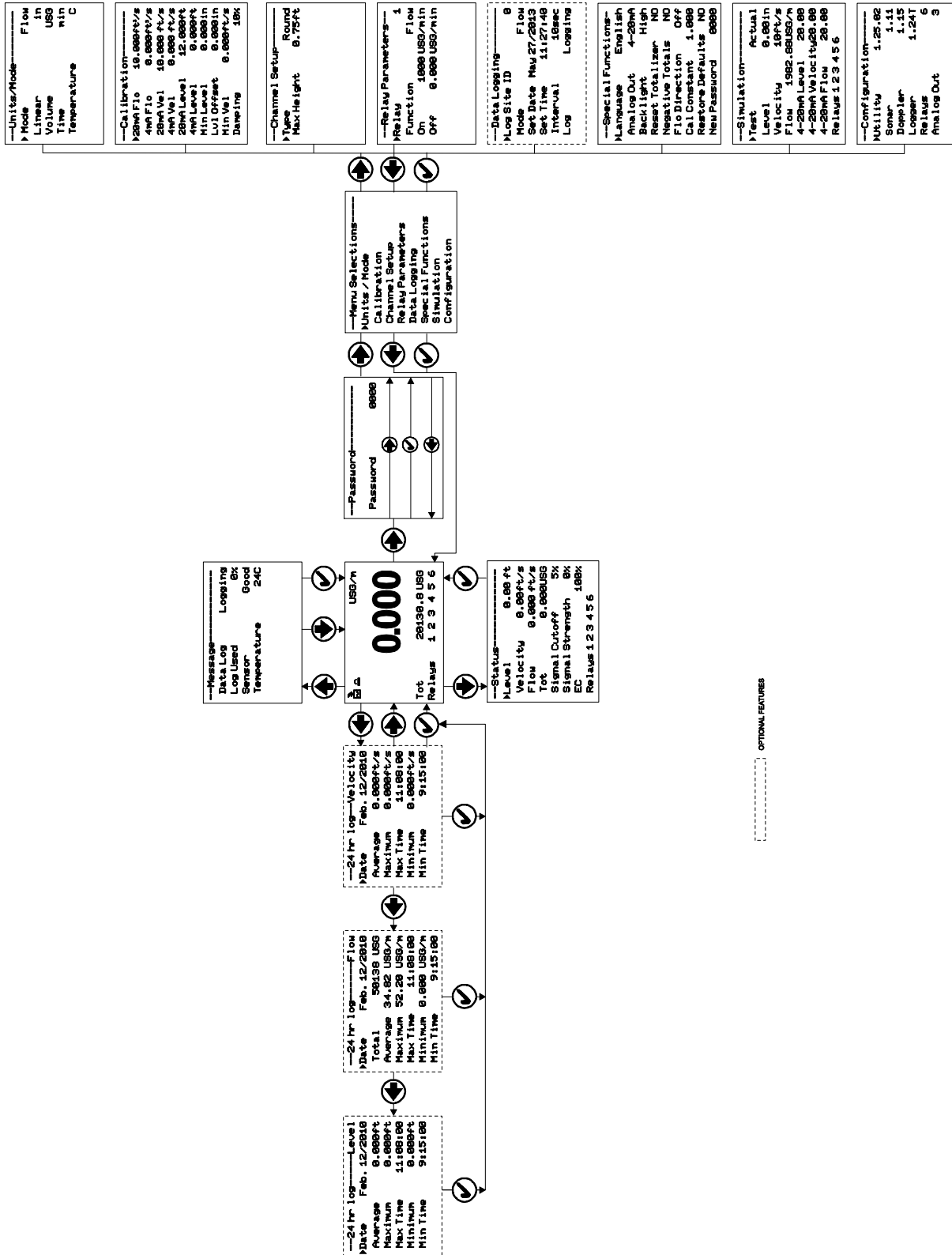

ICONS



Message waiting. Press .



Data logging off.



Data logging on.



USB file download.



File download completed.



Download Error.



Echo OK.



No Echo.

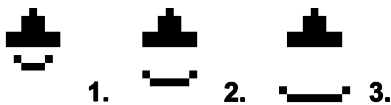

Echo OK (PZxx series level sensor option).



No Echo (PZxx series level sensor option).

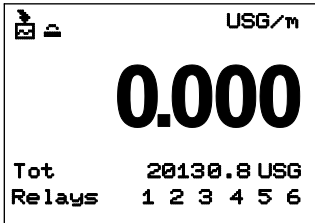

MAIN DISPLAY

The main display shows the units selected from the Units/Mode menu, Flow or Velocity rate being measured, TOTALIZER and RELAY states. The AVFM 5.0 will start-up with this display.

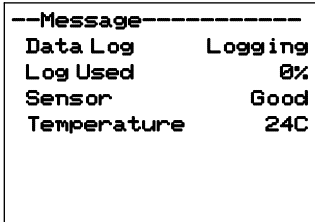

MESSAGE ICON

Press **↑** from the main display to view temperature measurement, status of the data logger and error/warning messages provided by the instrument. The Message Icon will appear on the main display if error messages are being generated by the instrument. Press **✓** to return to the main display.

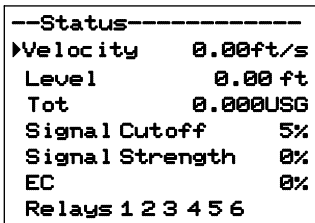

STATUS

Press **↓** from the MAIN display to view instrument status.

- Velocity Will be displayed in ft/sec or m/sec.
- Level Is displayed in the selected units.
- Tot Displays the current totalizer reading.
- Signal Cutoff Adjust the setting in percent to suppress flow readings at zero flow when fluid swirling or pipe vibration may cause the instrument to continue reading. Example: Signal Cutoff at 5% will force the display and outputs to zero when signal strength drops below 5%.
- Signal Strength Displays percentage of signal being received by the ultrasonic sensor.
- EC Displays level measurement Echo Confidence
- Relays 1 2 3 4 5 6 Energized relays will display with reversed font eg: **2**

| | |
|----------------------|--------------|
| --24 hr log-----Flow | |
| ▶Date | Feb. 12/2010 |
| Total | 50138 USG |
| Average | 34.82 USG/m |
| Maximum | 52.20 USG/m |
| Max Time | 11:08:00 |
| Minimum | 0.000 USG/m |
| Min Time | 9:15:00 |

24 HR LOG (Data Logging option only)

Press ◀ from the MAIN display to view a formatted flow report from instruments with a built-in data logger. Press ◀ to pan through Level, Velocity and Flow summaries. Press ↓ to scroll down one day or repeatedly to scroll to a specific date. Up to 365 days can be stored. Newest date will overwrite the oldest. Press ✓ to return to the main display.

| | |
|-----------------|------|
| --Password----- | |
| Password | 0000 |
| ▶ | → |
| ✓ | → |
| ◀ | → |

PASSWORD

The Password (a number from 0000 to 9999) prevents unauthorized access to the Calibration menu.

From the Main display press ▶ to get to Password. Factory default password is 0000 and if it has not been changed press ✓ to proceed to the Menu Selections screen.

If a password is required, press ▶ to place the cursor under the first digit and ↓ or ↑ to set the number, then ▶ to the second digit, etc. Press ▶ or ✓ to proceed to the Menu Selections screen.

A new password can be stored by going to Special Functions/New Password.

```

--Units/Mode-----
▶Mode                Flow
Linear              in
Volume             USG
Time               min
Temperature        C
  
```

UNITS/MODE

From ▶Mode press the ➡ and then the ⬆ or ⬇ to select Flow, Velocity or Level. Flow mode displays the flow rate in engineering units (e.g. gpm, litres/sec, etc.) Press the ✓ to store your selection then the ⬇ to the next menu item.

From ▶Linear press the ➡ key and then the ⬆ or ⬇ to select your units of measurement. Press the ✓ to store your selection.

```

--Units/Mode-----
Mode                Flow
▶Linear             in
                  ft
                  m
                  mm
  
```

Press the ⬇ key to move the ▶ symbol to each subsequent menu item and the ✓ to save your selections.

Note: the volume selection "bbl" denotes U.S. barrels.

▶ Temperature press ➡ then ⬆ ⬇ to select C or F.

```

--Units/Mode-----
Mode
Linear
▶Volume            USG
                  ft3
                  bbl
                  L
                  m3
                  IMG
                  IG
                  USMG
  
```

Press ⬅ or ✓ to return to the Menu Selections screen.

```

--Units/Mode-----
Mode                Flow
Linear              in
Volume             USG
▶Time              sec
                  day
                  hr
                  min
  
```

```

--Units/Mode-----
Mode                Flow
Linear              in
Volume             USG
Time               min
▶Temperature       C
                  F
  
```

| --Calibration----- | |
|--------------------|--------------------------|
| ▶20mA Flo | 10.000ft ³ /s |
| 4mA Flo | 0.000ft ³ /s |
| 20mA Vel | 10.000 ft/s |
| 4mA Vel | 0.000 ft/s |
| 20mA Level | 12.000ft |
| 4mA Level | 0.000ft |
| Min Level | 0.000in |
| Lvl Offset | 0.000in |
| Min Vel | 0.000ft/s |
| Damping | 10% |

CALIBRATION

Press **↓** to Calibration and **→** to enter. Use **↓** or **↑** to position **▶** before each menu item and **→** to enter. When settings are completed press **✓** to store and return to the Calibration menu.

20mA Flo [5V Flo] Press **→** and enter the flow rate value for 20mA.

Note: Analogue output can be selected as 4-20mA or 0-5V in Special Functions.

4mA Flo [0V Flo] Press **→** and enter the flow rate value for 4mA.

20mA Vel [5V Vel] Press **→** and enter the velocity value for 20mA.

4mA Vel [0V Vel] Press **→** and enter the velocity value for 4mA.

20mA Level [5V Level] Optional for QZ02L-A type sensor. Press **→** and enter the level value for 20mA.

4mA Level [0V Level] Optional for QZ02L-A type sensor. Press **→** and enter the level value for 4mA.

MaxRg Only for PZ15LP/QZ02L-B type sensor. Press **→** and enter the zero water level (distance from the PZ15-LP sensor to the zero water level).

MinRg Only for PZ15LP/QZ02L-B type sensor. Press **→** and enter the max level (distance from the PZ15-LP sensor to the max water level).

Min Level Optional for QZ02L-A type sensor. Press **→** and enter a minimum level cutoff. Level reading less than Min Level will be forced to zero.

Lvl Offset

Optional for QZ02L-A type sensor. Press **➡** and enter an offset to level measurement. Set to 0.00 when sensor mounted on floor of channel. When sensor is mounted above the floor of the channel enter the distance between channel floor and bottom of sensor. Maximum offset is $\pm 36''$ (914 mm).

Note: 4mA is not affected by Lvl Offset settings. 4mA is the bottom of the channel or pipe.

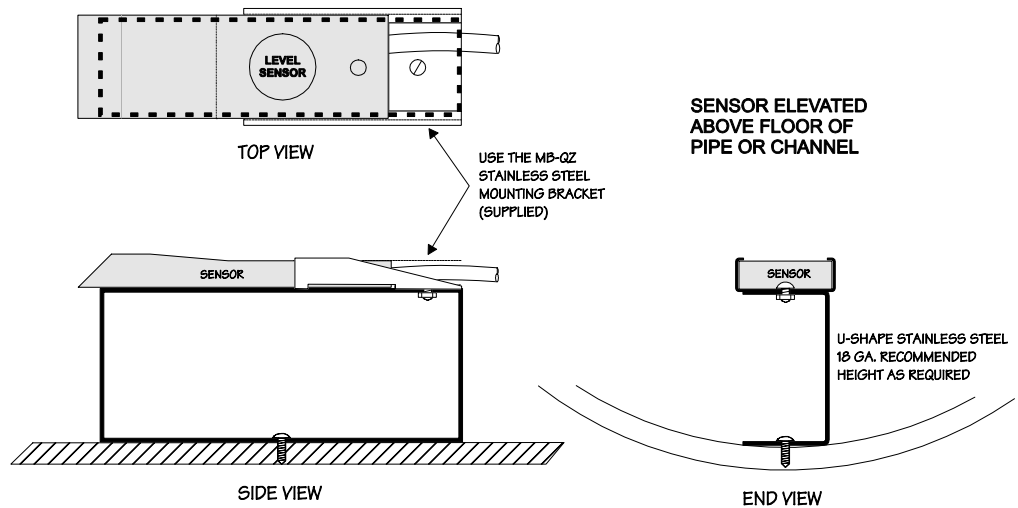

Min Vel

Press **➡** and enter a minimum velocity cutoff. Forward and reverse velocities less than Min Vel will be forced to zero.

Damping

Increase damping to stabilize readings under turbulent flow readings or to reject spurious level readings. Decrease for faster response to changes in flow.

Press **✓** from the Calibration display to return to Menu Selections.

```

--Channel Setup-----
▶Type           Round
Max Height      0.75ft
    
```

CHANNEL SETUP

Round Select **Round** for open pipes. Set **Max Height** to the inner diameter of the pipe.

Rectangle Select **Rectangle** for rectangular channels. Enter the channel width.

Trapezoid Select **Trapezoid** for trapezoidal shaped channels. Specify the **Width** and **Slope** of the channel as shown in the following illustration.

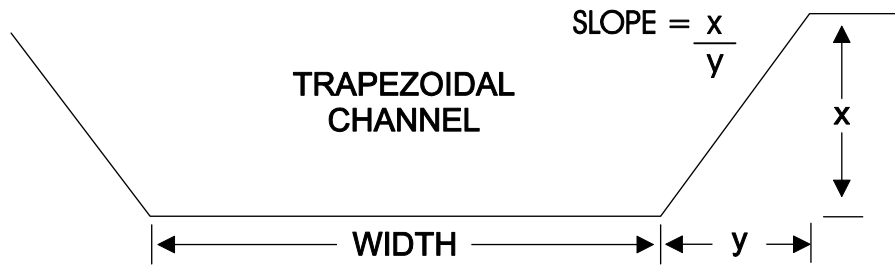

Egg Select **Egg** for Egg shaped channels. Enter the **Max Height** of the channel.

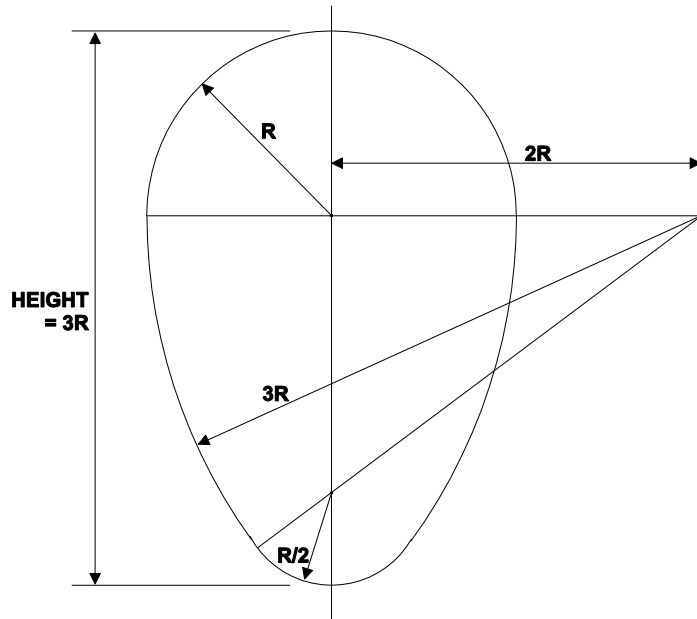

```

--Custom Channel-----
▶Type           Custom
Reset Data      No
Max Height      0.75 ft
Division        0.05 ft
Increment #     0
Width           0.000 ft
Level           0.000 ft
  
```

CUSTOM CHANNELS

- Reset Data Old data MUST be removed before entering data for a new channel. Press **➡** then press **⬆** to Yes and press **✓** to clear old data.
- Max Height Enter the maximum height of the channel.
- Division Divide the maximum height into equal increments (maximum of 40) and enter this division value (example 1", 1 cm etc.)
- Increment # Enter the increment number if you want to edit a previous entry or to skip entering widths for some levels (Note: The custom channel will interpolate widths between entry points).
- Width Enter the measured width of the channel at the level shown (Note: To enter 0 width you must press **➡** and then **✓** to store a 0 width data point).
- Level Displays the level of the channel for each increment and width entry.

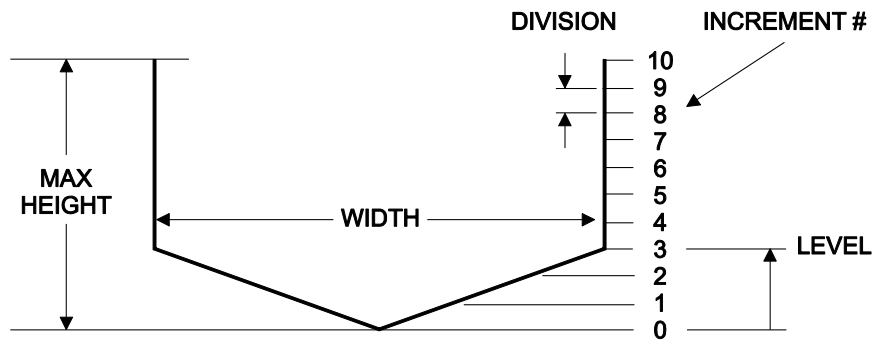

Note:

Custom channel data in equal width increments with variable height measurements must be converted to the format shown above using the "Channel Data Translator" PC software.

```

--Relay Parameters--
▶Relay              1
Function            Flow
On                  1000 USG
Off                 0.000 USG
  
```

RELAY PARAMETERS

Relay Press **➡** and **⬇** or **⬆** to select a relay (2 relays are standard, 4 additional are optional).

Function Press **⬇** or **⬆** to select Off, Pulse, Flow, Velocity or Level.

Flow

- On Position the cursor under the numerals and press **⬇** or **⬆** to set digits to the relay On set point.
- Off set digits to the Off set point.

Pulse Press **⬇** and set digits to the flow volume per relay pulse. Use this feature for remote samplers, chlorinators or totalizers. Minimum time between pulses is 2.25 seconds and pulse duration is 350 milliseconds.

Return to Relay and enter settings for each relay.

Velocity

- On Position the cursor under the numerals and press **⬇** or **⬆** to set digits to the relay On set point.
- Off set digits to the Off set point.

Level

- On Position the cursor under the numerals and press **⬇** or **⬆** to set digits to the relay On set point.
- Off set digits to the Off set point.
- LOE mode Specify the state of the relay for loss of echo condition: Off, On or Hold.

Press **✓** to return to Menu Selections

DATA LOGGING (OPTIONAL)

Refer to Options section of this manual.

SPECIAL FUNCTIONS

```
--Special Functions--
▶Language      English
Analog Out     4-20mA
Backlight      High
Reset Totalizer NO
Negative Totals NO
Flo Direction  Off
Cal Constant   1.000
Restore Defaults NO
New Password   0000
```

```
--Special Functions--
Language      English
▶Backlight     High
               Medium
               Low
               Key Hi/Lo
               Key High
               Key Med
               Key Low
               Off
```

| | |
|------------------|--|
| Language | Select English, French or Spanish |
| Analog Out | Select 4-20mA or 0-5V mode for the analog output. |
| Backlight | Select High, Medium or Low for continuous backlight. Select Key Hi/Lo for high backlight (for 1 minute) after a keypress and then Lo backlight until a key is pressed again. Select Key High, Med or Low for backlight after a keypress and then backlight off until a key is pressed again. |
| Reset Totalizer | Press ➡ and select Yes to erase and restart the totalizer at zero. |
| Negative Totals | Select Yes to have reverse flow readings deducted from the totalizer. Select No to totalize forward flow only and ignore reverse flow. |
| Flo Direction | Select On to enable flow direction measurement. Select Off to disable flow direction measurement so that flow in either direction is displayed and output as positive values. Select Invert to invert the sense of the flow measurement. |
| Cal Constant | Scales the velocity reading. Set to 1.000 for QZ02L sensor. |
| Restore Defaults | Select Yes and press ✓ to erase all user settings and return the instrument to factory default settings. |
| New Password | Select any number from 0000 to 9999 and press ✓ . Default setting of 0000 will allow direct access to the calibration menus. Setting of any password greater than 0000 will require the password to be entered to access the calibration menus. |

Press **✓** to return to Menu Selections.

| --Simulation----- | |
|-------------------|--------------|
| ▶Test | Actual |
| Level | 0.00in |
| Velocity | 10ft/s |
| Flow | 1982.88USG/m |
| 4-20mA Level | 20.00 |
| 4-20mA Velocity | 20.00 |
| 4-20mA Flow | 20.00 |
| Relays | 1 2 |

SIMULATION

Exercises the 4-20mA (0-5V) outputs, digital display and control relays.

Test Select **Maximum** and press ✓ to simulate maximum Flow, Level and Velocity and to output 20mA (5V) to the analog channels.

Select **Minimum** and press ✓ to simulate minimum Flow, Level and Velocity and to output 4mA (0V) to the analog channels.

To simulate an intermediate Flow, Level and Velocity set **Test** to **Actual** and then enter a value for the **Level** and **Velocity**. The Flow calculation, analog outputs and control relays will respond to the simulated values.

INSTALLATION - SENSOR LOCATION

1. Choose a sensor mounting location where silt or deposits are least likely to accumulate.
2. For best results flow should be evenly distributed across the channel and relatively free of turbulence. (The AVFM 5.0 is very effective at averaging level and velocity readings in turbulent conditions, but best accuracy and response time is achieved with evenly distributed flow.)
3. Avoid vertical drops, obstructions or elbows immediately up and downstream from the sensor. Locate the QZ02L sensor at least 10 times maximum Head (level) and 10 times the channel width from these flow disturbances.
4. The QZ02L submerged level-velocity sensor requires a minimum water level of 1 in. (25.4 mm).

QZ02L VELOCITY-LEVEL SENSOR MOUNTING

Mount the QZ02L sensor with the stainless steel bracket and hardware supplied. Ensure that the sensor is parallel to the water surface (check with a level). Mount with the tapered end of the sensor pointing upstream and the sensor cable pointing downstream.

Clip or tie wrap the sensor cable securely to the pipe or channel wall.

Note: The mounting bracket is designed to release the sensor if weeds or rags are caught by the sensor.

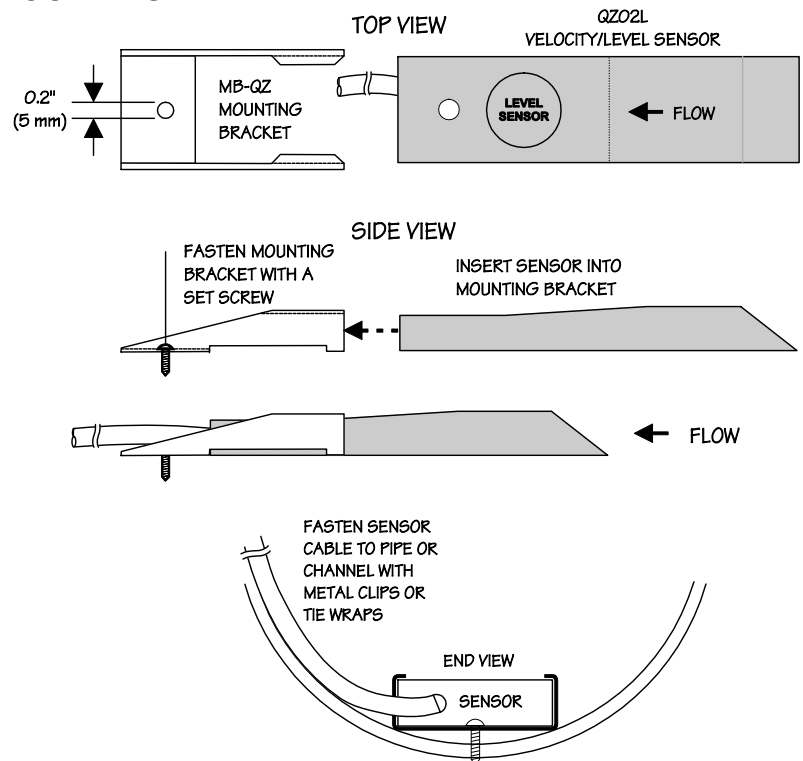

GOOD

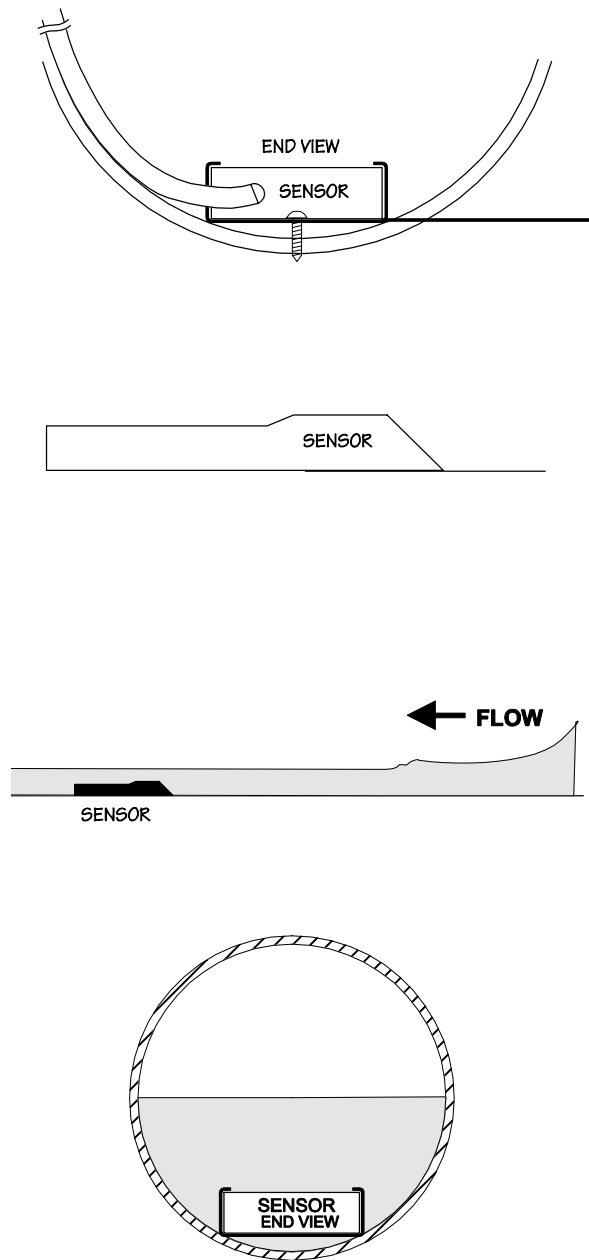

BAD

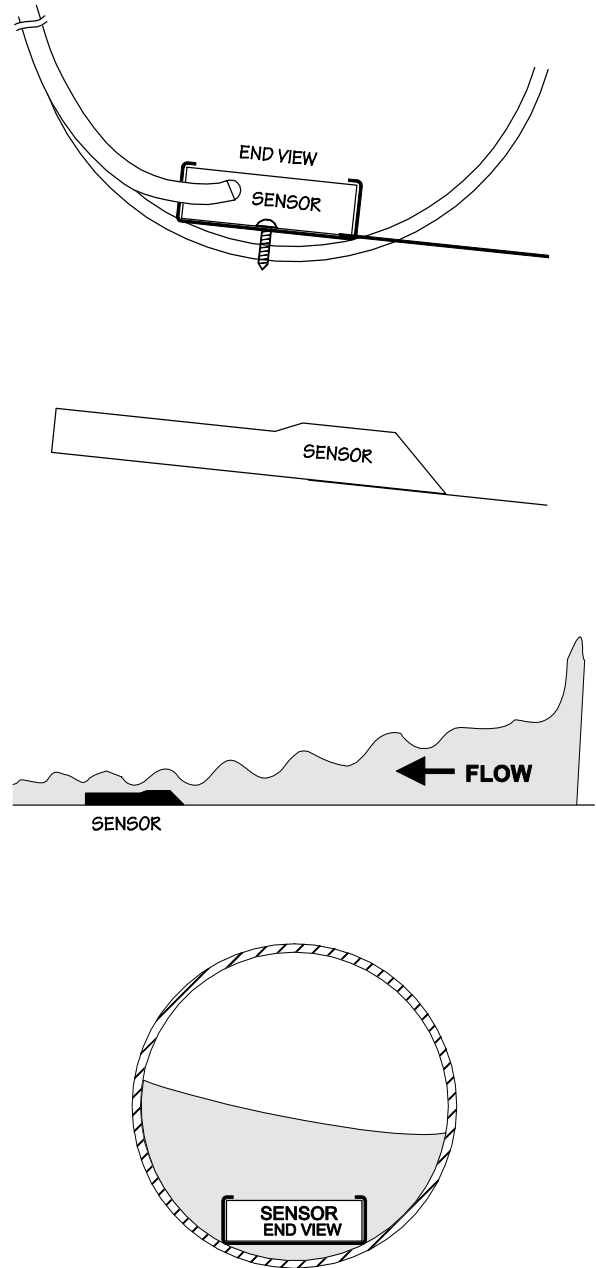

OPTIONAL PIPE BAND MOUNTING WITH QZ02L SENSOR

Install the stainless steel pipe band with the sensor mounting bracket at the invert (bottom) of the pipe. Ensure that the sensor bracket is parallel to the water surface (check with a level). Mount so the tapered end of the sensor will point upstream and the sensor cable will point downstream. (Turn the 1/4" adjustment nut clockwise to expand the bracket and secure to the pipe wall by friction fit.)

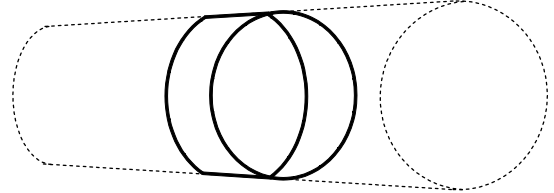

Insert the sensor into the mounting bracket and tie-wrap the sensor cable securely to the pipe band using the holes provided.

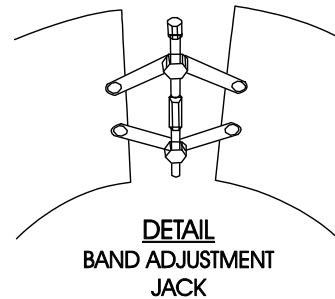
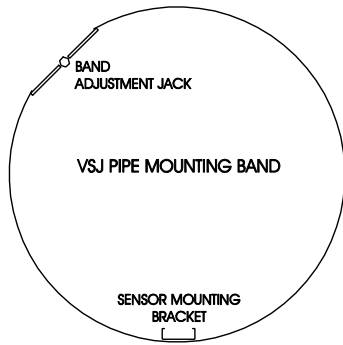

OPTIONAL QZ02L-DP VELOCITY SENSOR MOUNTING

Mount the velocity sensor at or near the bottom of the channel or pipe in a position where it will be continuously submerged. The QZ02L-DP velocity sensor does not have to be parallel to the water surface. Position where silt or solids will not build-up on the sensor.

OPTIONAL PZ15-LP LEVEL SENSOR MOUNTING

Mount the PZ15-LP non-contacting ultrasonic level sensor in an unobstructed position at least 8" (203.2 mm) above the high water level. Install the stainless steel mounting bracket in a horizontal position (check with a level) and then insert the PZ15-LP sensor.

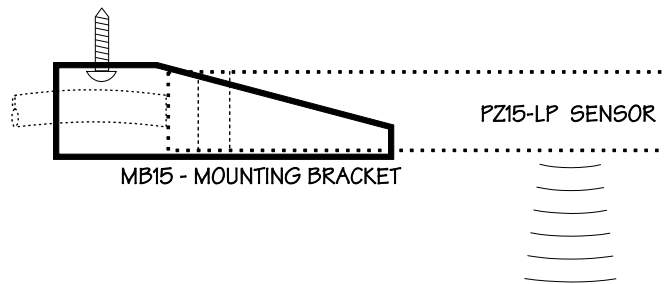

PZ15-LP MANHOLE MOUNTING

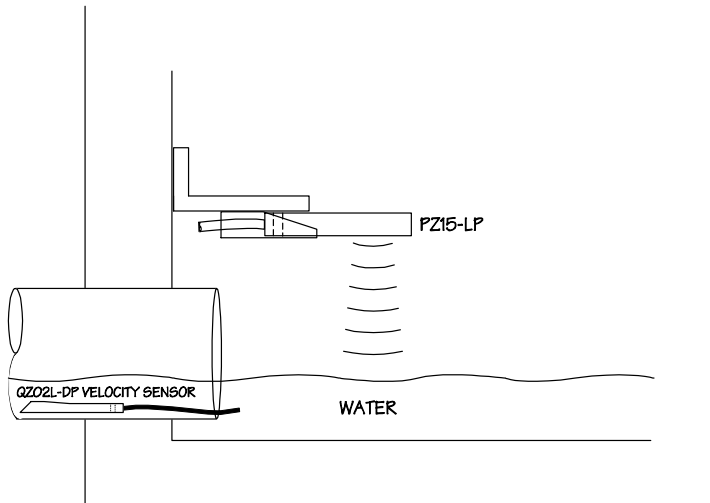

PZ15-LP PIPE MOUNTING

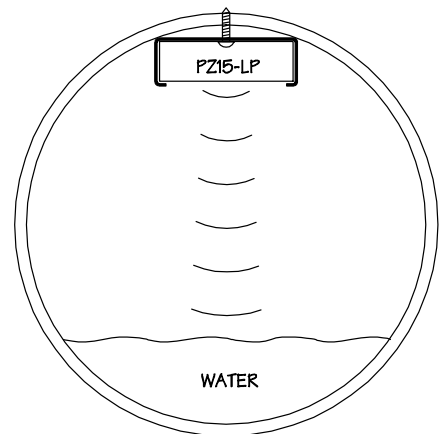

ENCLOSURE INSTALLATION

Locate the enclosure within 20 ft (6 m) of the sensor (up to 500 ft -150 m optional). The enclosure can be wall mounted with the four mounting screws (included) or panel mounted with Option PM Panel Mount kit from Greyline Instruments.

Avoid mounting the enclosure in direct sunlight to protect the electronics from damage due to overheating and condensate. In high humidity atmospheres, or where temperatures fall below freezing, Option TH Enclosure Heater and Thermostat is recommended. Seal conduit entries to prevent moisture from entering enclosure.

NEMA4X (IP66) WITH CLEAR COVER

1. Open hinged enclosure cover.
2. Insert #12 screws (supplied) through the four enclosure mounting holes to secure the enclosure to the wall or mounting stand.

Additional conduit holes can be cut in the bottom of the enclosure with a hole saw or Greenlee-type hole cutter.

DO NOT make conduit/wiring entries into the top of the enclosure.

Note: This non-metallic enclosure does not automatically provide grounding between conduit connections. Grounding must be provided as part of the installation. Ground in accordance with the requirements of the National Electrical Code. System grounding is provided by connecting grounding wires from all conduit entries to the steel mounting plate or another point which provides continuity.

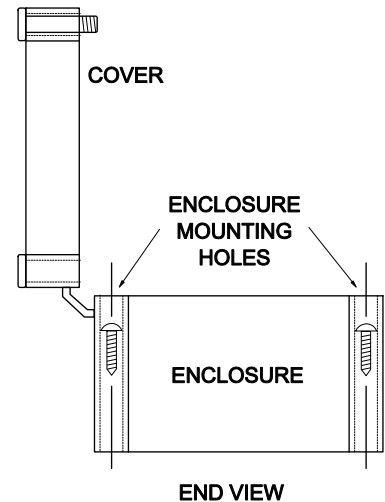

CLEANING

Cleaning is not required as a part of normal maintenance.

FUSE REPLACEMENT

1. Turn OFF power.
2. Loosen cover screw and open.
3. Remove power module.
4. Locate fuse on Power Board.
5. Replace fuse with 2 AMP/ 250V, 5 x 20mm fuse.
6. Reinstall power module into chassis.

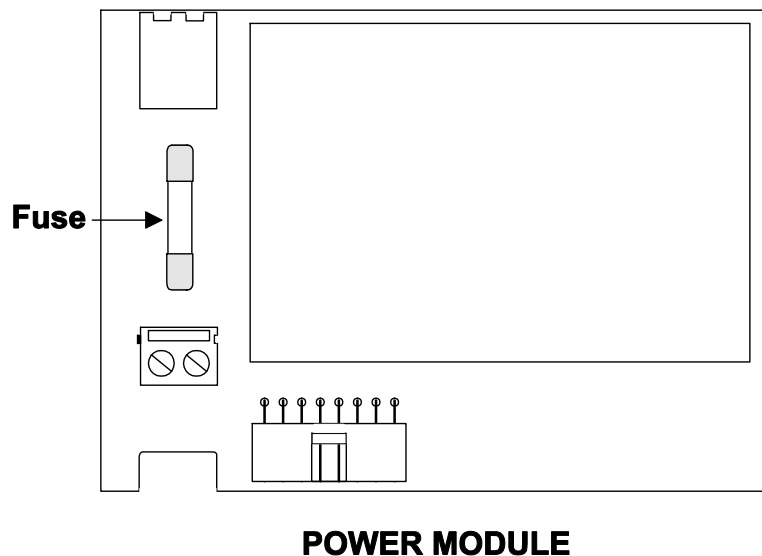

FIELD TROUBLESHOOTING

The AVFM 5.0 uses an ultrasonic level sensor to determine channel AREA and an ultrasonic Doppler sensor to measure flow VELOCITY.

The QZ02L sensor combines both sensors in one housing.

An optional configuration uses the PZ15-LP “down-looking” level sensor and a QZ02L-DP velocity sensor.

To troubleshoot the AVFM 5.0, verify correct operation of LEVEL and VELOCITY measurements separately.

Note: Selecting “Defaults” in the SPECIAL FUNCTION menu will return the instrument to “as-shipped” factory settings.

LEVEL (QZ02L SENSOR)

SYMPTOMS

EC bar graph at zero

- Level display reads 1.0 inches

FAULTS

- very turbulent flow
- very aerated flow
- sensor not level
- sediment/dirt/grease build-up on sensor
- Level at or less than 1.0 inches

SOLUTIONS

- relocate sensor or use PZ15-LP
- level sensor with “Bullseye” level
- clean sensor with liquid soap

VELOCITY (QZ02L SENSOR)

SYMPTOMS

- No velocity reading

FAULTS

- Grease/sediment on sensor
- Improper hook-up

SOLUTIONS

- Clean sensor with detergent
- Check sensor connections

SENSOR CABLE RESISTANCE TEST

Unplug the green sensor terminal from the Doppler board and connect the sensor wires as shown. With a multimeter, perform resistance checks for each set of wires. One single loose terminal may cause false readings.

Test across shield and core of each wire: TMTR (black/white) and RCVR (black). Resistance should be approximately 82.5K ohms for any cable length. High readings indicate an open circuit and low readings indicate a short or partial short in the sensor cable.

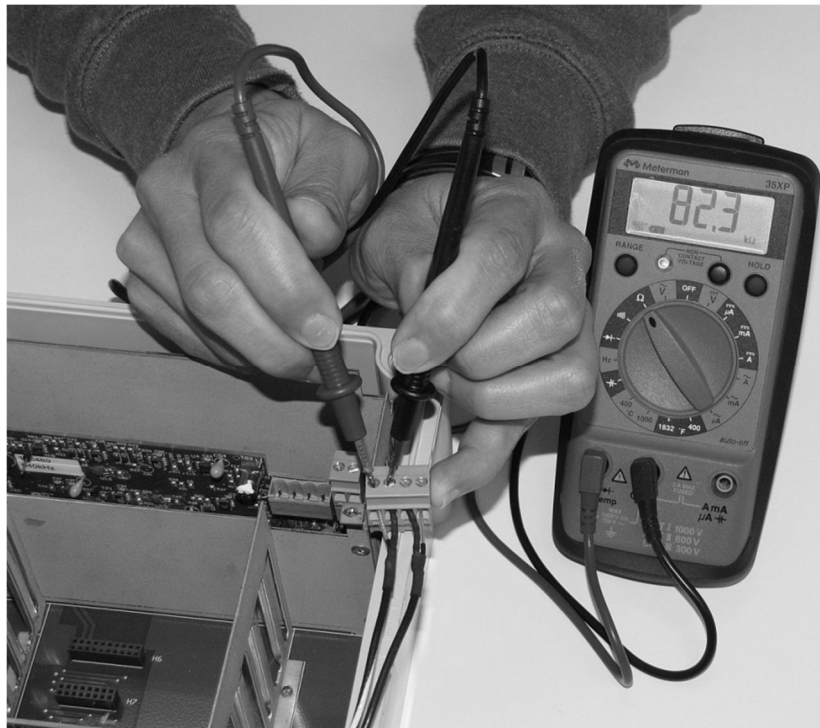

APPLICATIONS HOTLINE

For applications assistance, advice or information on any Greyline Instrument contact your Sales Representative, write to Greyline or phone the Applications Hotline below:

| | | |
|----------------|-------------------|-------------------|
| United States: | Tel: 315-788-9500 | Fax: 315-764-0419 |
| Canada: | Tel: 613-938-8956 | Fax: 613-938-4857 |
| Toll Free: | 888-473-9546 | |
| Email: | info@greyline.com | |
| Web Site: | www.greyline.com | |

Greyline Instruments Inc.

Canada
16456 Sixsmith Drive
Long Sault, Ont. K0C 1P0

USA:
11451 Belcher Road South
Largo, FL 33773

PRODUCT RETURN PROCEDURE

Instruments may be returned to Greyline for service or warranty repair.

1 Obtain an RMA Number from Greyline -

Before shipping a product to the factory please contact Greyline by telephone, fax or email to obtain an RMA number (Returned Merchandise Authorization). This ensures fast service and correct billing or credit.

When you contact Greyline please have the following information available:

1. Model number / Software Version
2. Serial number
3. Date of Purchase
4. Reason for return (description of fault or modification required)
5. Your name, company name, address and phone number

2 Clean the Sensor/Product -

Important: unclean products will not be serviced and will be returned to the sender at their expense.

1. Rinse sensor and cable to remove debris.
2. If the sensor has been exposed to sewage, immerse both sensor and cable in a solution of 1 part household bleach (Javex, Clorox etc.) to 20 parts water for 5 minutes. Important: do not immerse open end of sensor cable.
3. Dry with paper towels and pack sensor and cable in a sealed plastic bag.
4. Wipe the outside of the enclosure to remove dirt or deposits.
5. Return to Greyline for service.

AREA-VELOCITY FLOW DATA SHEET

| | |
|---|--|
| <p>Greyline Instruments Inc. 16456 Sixsmith Dr., Long Sault, Ont. K0C 1P0 Tel: 613-938-8956 / Fax: 613-938-4857 11451 Belcher Road South, Largo, FL 33773 Tel: 315-788-9500 / Fax: 315-764-0419</p> | <p><i>Please complete and return this form to Greyline. It is important. We use this information to check our database for performance of Greyline flow meters in similar applications, and to provide advice and recommendations to you. Thanks for your cooperation.</i></p> |
| <p>Contact: _____ Title/Dept.: _____ Company: _____ Project: _____ Address: _____ Tel: _____ Fax: _____</p> | |
| <p>SENSOR: Model/Type: _____ Cable Length: _____ Elec. Class: _____ Type of Pump: _____ Distance from nearest Pump, Controlling Valve, Orifice or open Discharge: _____</p> | |
| <p>INSTRUMENT: Model/Type: _____ Power Input: _____ Calibrated Range: _____ Indication: _____ Operating Temp.: _____ Alarm: _____ Enclosure Class: _____ Pulse/Unit: _____ Elec. Class: _____ Output: _____</p> | |
| <p>SERVICE CONDITIONS: Pipe ID: _____ <input type="checkbox"/> Vertical <input type="checkbox"/> Horizontal Pipe Mat'l: _____ % Solids: _____ Fluid: _____ Material Build-up: _____ Oper. Flow: _____ Vibration: _____ Max. Flow: _____ Max. Pressure: _____ Min. Flow: _____ Max. Temp: _____</p> | |
| <p>Notes / Sketch Pipe Run:</p> | |
| <p>By: _____ Date: _____</p> | |

LIMITED WARRANTY

Greyline Instruments warrants, to the original purchaser, its products to be free from defects in material and workmanship for a period of one year from date of invoice. Greyline will replace or repair, free of charge, any Greyline product if it has been proven to be defective within the warranty period. This warranty does not cover any expenses incurred in the removal and re-installation of the product.

If a product manufactured by Greyline should prove defective within the first year, return it freight prepaid to Greyline Instruments along with a copy of your invoice.

This warranty does not cover damages due to improper installation or handling, acts of nature, or unauthorized service. Modifications to or tampering with any part shall void this warranty. This warranty does not cover any equipment used in connection with the product or consequential damages due to a defect in the product.

All implied warranties are limited to the duration of this warranty. This is the complete warranty by Greyline and no other warranty is valid against Greyline. Some states do not allow limitations on how long an implied warranty lasts or limitation of incidental or consequential damages, so the above limitations or exclusions may not apply to you.

This warranty gives you specific legal rights, and you may also have other rights which vary from state to state.

Greyline Instruments Inc.

APPENDIX A – OPTIONS

EXTRA SENSOR CABLE (OPTION VXC)

Each Greyline AVFM 5.0 flow meter includes 26.25 ft. (8 m), 50 ft. (15 m) or 100 ft. (30 m) tri-coaxial sensor cable. This cable is shielded from electrical interference and is watertight with a polyurethane jacket. Additional cable and Cable Junction Box (Option JB2X or JB4X) may be ordered with the Flow Meter, or the cable may be spliced and extended up to 500 ft (152 m) total length as required during installation. No adjustment is required when the sensor cable is extended or shortened. Use only Greyline tri-coaxial VXC shielded cable, or run three RG174U coaxial cables in a metal conduit.

Extended sensor cable can be installed in conduit for mechanical protection. Recommended installation with a junction box is illustrated below:

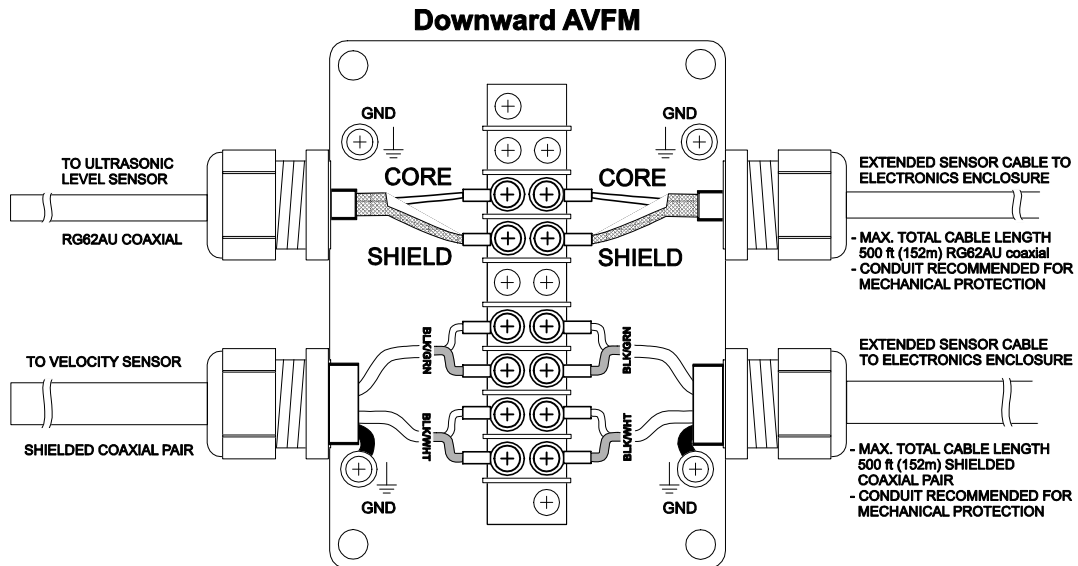
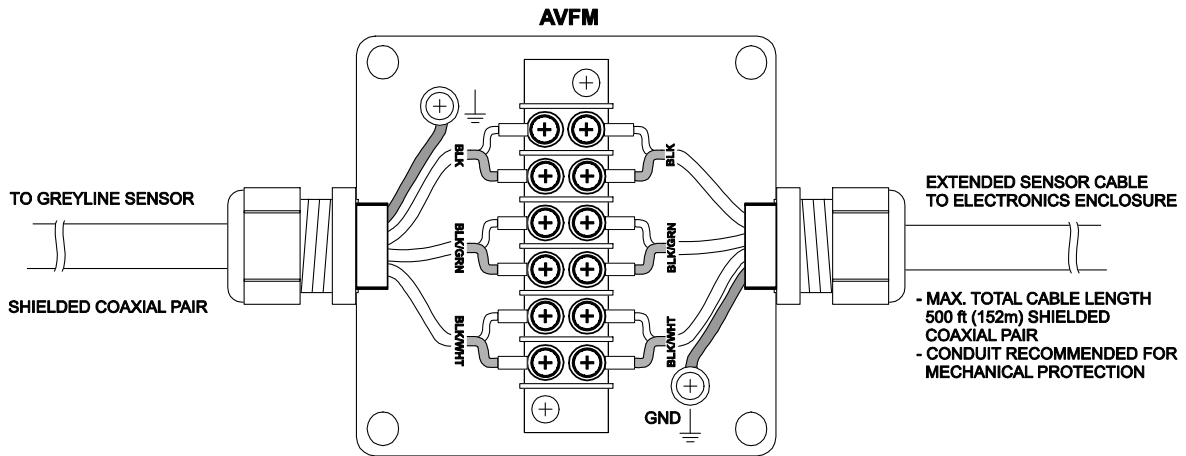

COAXIAL CABLE PREPARATION

VXC Doppler sensor cable can be cut and spliced up to a maximum length of 500 ft (152 m). Cable ends must be prepared as illustrated below.

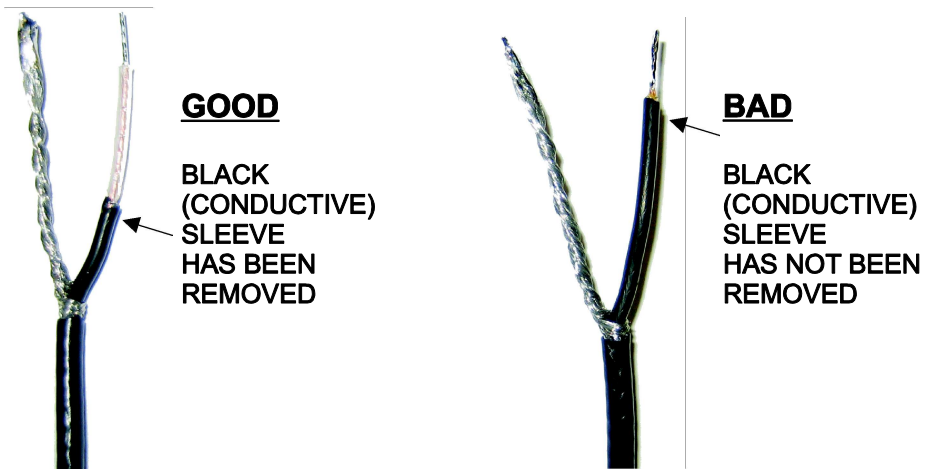

JUNCTION BOX - OPTION JB2X & JB4X

NEMA4X (IP66) polycarbonate Junction Box with terminal strips is available from Greyline Instruments. Includes compression fittings for watertight coaxial cable entries.

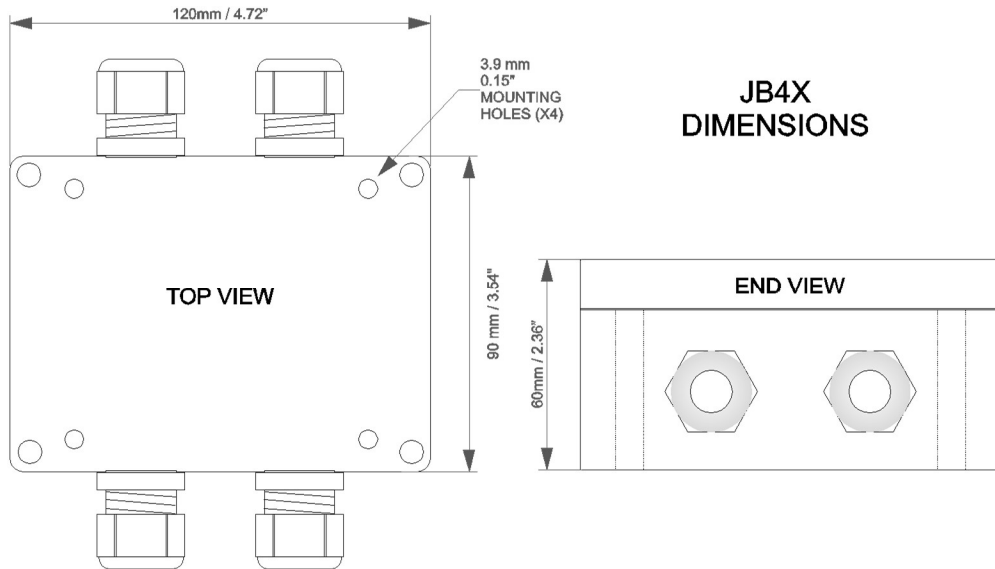
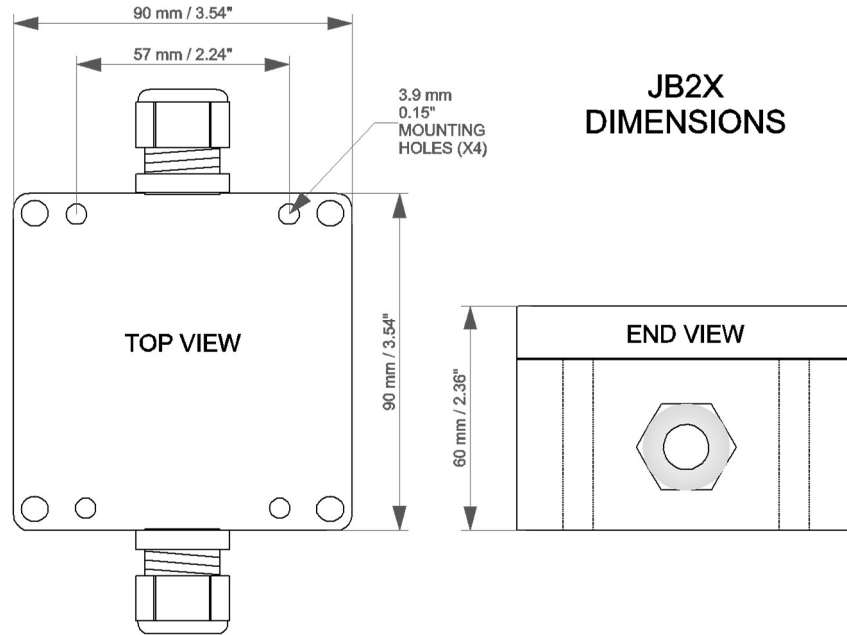

SS PIPE MOUNTING BAND – OPTION VSJ

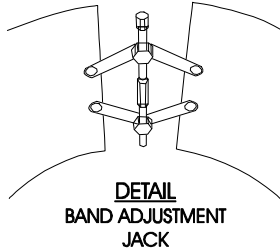

Use optional VSJ stainless steel Pipe Mounting Bands for easy Sensor installation in round pipes.

Each Pipe Band includes:

- ✓ Band Adjustment Jack allowing $\pm 0.5"$ (13 mm) adjustment from the nominal band size
- ✓ Stainless steel bracket for Sensor mounting
- ✓ Pre-drilled for tie wraps (included) to secure Sensor cable

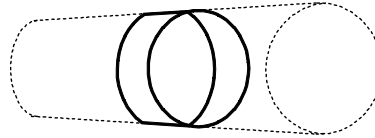
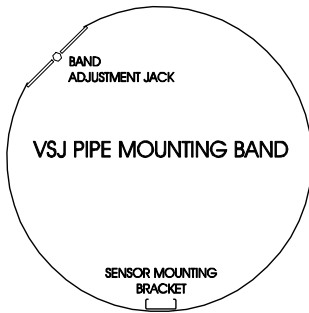

CODE BAND SIZE

| | |
|-------|---------------------|
| VSJ6 | 6"/150 mm ID pipes |
| VSJ8 | 8"/200 mm ID pipes |
| VSJ10 | 10"/250 mm ID pipes |
| VSJ12 | 12"/300 mm ID pipes |
| VSJ14 | 14"/350 mm ID pipes |
| VSJ15 | 15"/375 mm ID pipes |
| VSJ16 | 16"/400 mm ID pipes |
| VSJ18 | 18"/450 mm ID pipes |
| VSJ20 | 20"/500 mm ID pipes |
| VSJ24 | 24"/600 mm ID pipes |
| VSJ30 | 30"/750 mm ID pipes |

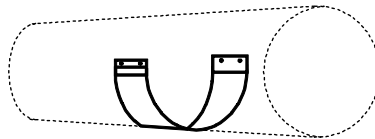
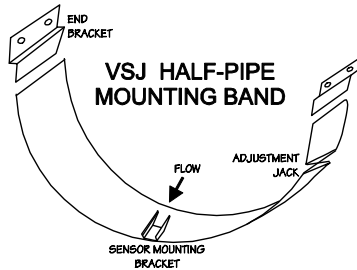

| | |
|----------|--------------------------------|
| VSJ32-40 | 32-40" / 800-1000 mm ID pipes |
| VSJ42-54 | 42-54" / 1100-1375 mm ID pipes |
| VSJ56-72 | 56-72" / 1400-1800 mm ID pipes |

Mounting Instructions:

Install the stainless steel pipe band with the sensor mounting bracket at the invert (bottom) of the pipe. Ensure that the sensor bracket is parallel to the water surface (check with a level). Mount so the tapered end of the sensor will point upstream and the sensor cable will point downstream. Turn the $\frac{1}{4}"$ adjusting nut clockwise to expand the bracket and secure to the pipe wall by friction fit.

Insert the sensor into the mounting bracket and tie wrap the sensor cable securely to the stainless steel pipe band.

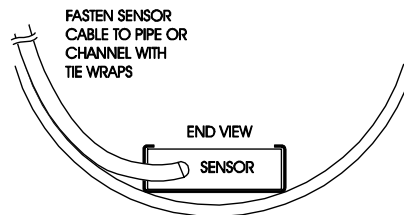

SENSOR INTRINSIC SAFETY

When connected through Intrinsic Safety Barriers, the Greyline Sensor Model QZ02L and PZ series are CSA certified for installation in a hazardous location rated:

Class I, Groups C,D
Class II, Groups E,F,G
Class III

Intrinsic Safety Barriers may be ordered with the Greyline instrument and are supplied mounted in the Greyline instrument enclosure. Replacement barrier fuses (Part No. ISB- 011239) may be purchased separately. The instrument enclosure containing the Intrinsic Safety Barriers must be installed in a non-hazardous location.

GN3SPEC-ISB-02

The intrinsic safety barrier assemblies installed in the AVFM 5.0 limit the voltage and current supplied to the transducers to the values listed under 'Barrier Specifications'. To safely install Greyline transducer(s) certified for use in hazardous locations you must refer to the installation drawings/specifications of the certified transducer(s).

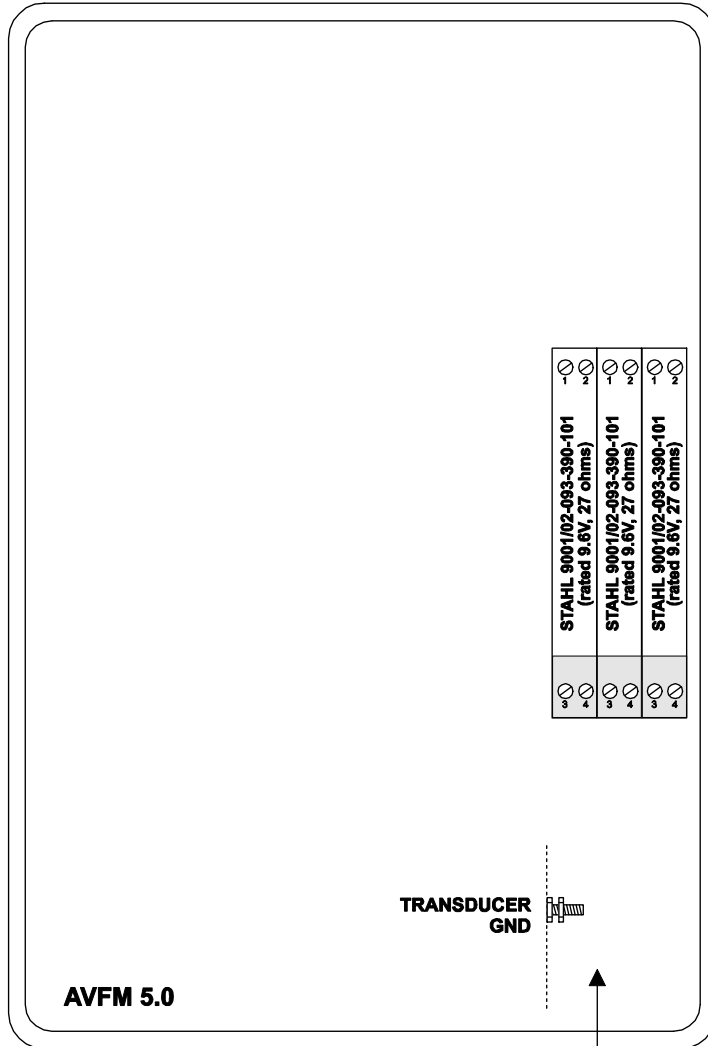

Installed in
Non-Hazardous Location

TRANSDUCER
CONNECTIONS

BARRIER SPECIFICATIONS

| STAHL BARRIER | System Parameters | Entity Parameters | | | | | |
|---------------------|-------------------|-------------------|----------|----------|---------|-------------|--------|
| | | U_m | V_{oc} | I_{sc} | P_0 | C_a | L_a |
| 9001/02-093-390-101 | 9.6V, 27 ohms | 250V | 9.3V | 390mA | 906.8mW | 4.1 μ F | 0.16mH |

ENCLOSURE HEATER AND THERMOSTAT - Option TH

Instruments can be factory-equipped with an Enclosure Heater and Thermostat or the module can be customer-installed. The Thermostat is factory set to turn ON at 40°F (4.5°C) and OFF at 60°F (15.5°C). Power consumption is 15 Watts.

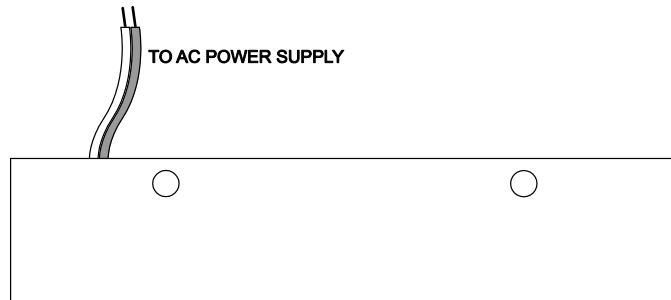

ENCLOSURE SUNSCREEN - Option SCR

Do not mount instrument electronics in direct sunlight. Overheating will reduce the life of electronic components and condensate may form during the heat/cool cycles and cause electrical shorts.

Note:

Exposure to direct sunlight can cause overheating and moisture condensation which will reduce the operating life of electronics.

Protect Instruments from direct sunlight with this iridite finished aluminum sun screen (Greyline Option SCR).

Seal conduit entries with caulking compound to further reduce moisture condensation.

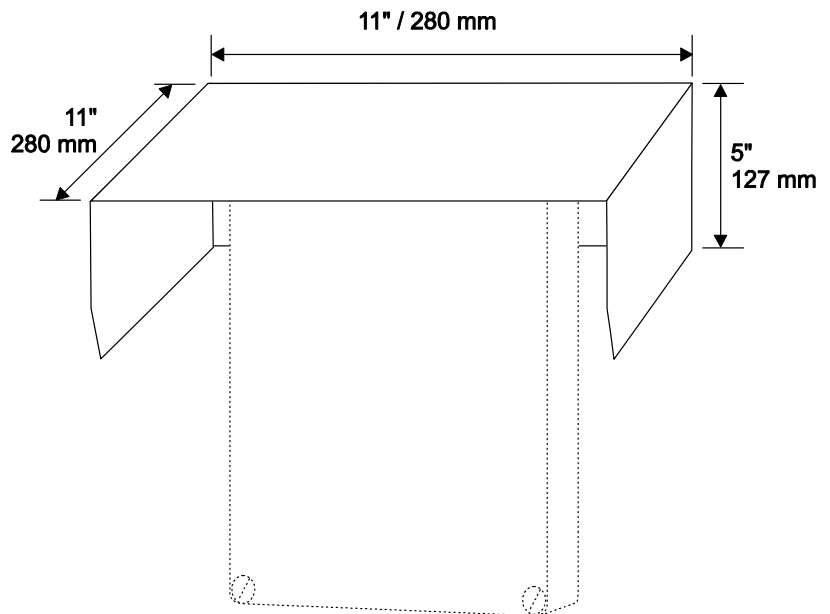

**POWER INPUT OPTION
9-32VDC**

AVFM 5.0 Flow Meters may be ordered factory-configured for 9-32VDC power input.

CONNECTIONS:

POWER INPUT: Connect 9-32VDC to the + and - terminals. The Power Input GND terminal must be connected to the nearest Ground pole. A 1-amp fuse in line is recommended.

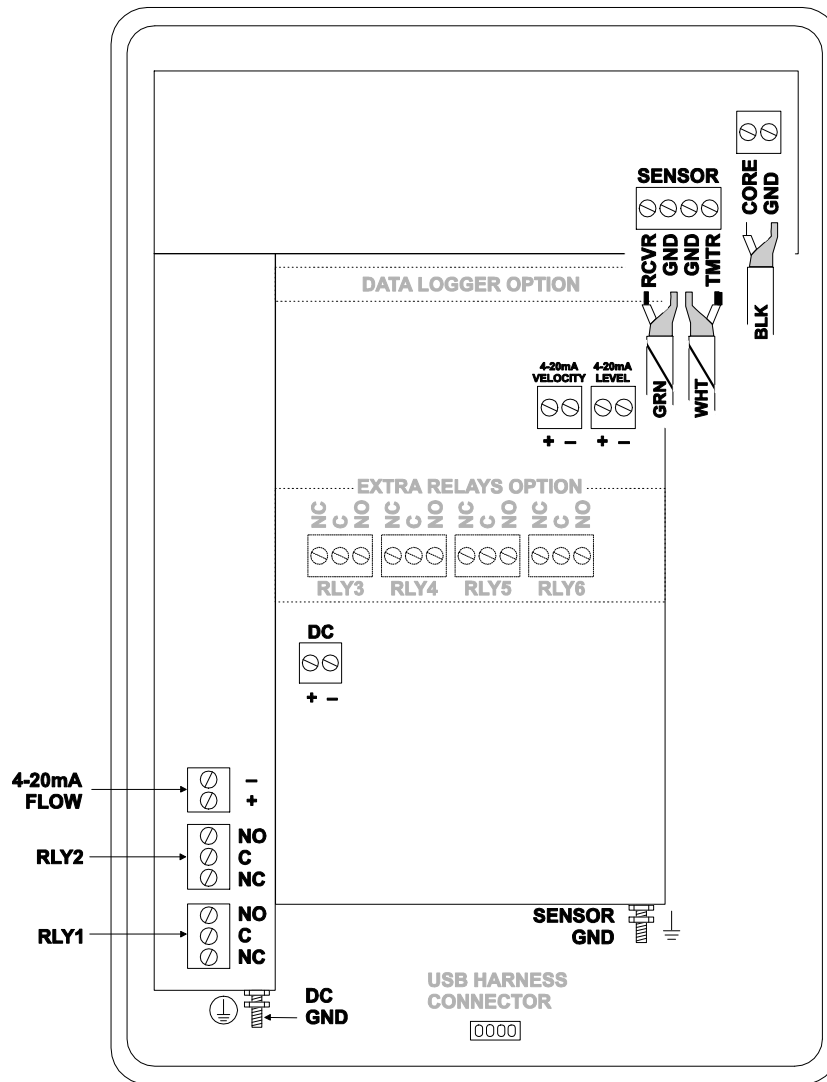

```

--Data Logging-----
Log Site ID      00
                  99
Mode             Flow
                  Velocity
Set Date        Feb 18/2008
                  Mar 19/2009
Set Time        11:27:40
                  12:28:41
Interval        10sec
                  60min
                  30min
                  15min
                  10min
                  5min
                  2min
                  1min
                  30sec
Log             Stop
                  Start
                  Delete
  
```

DATA LOGGING (Optional)

Setup

Select Data Logging from Menu Selections.

- Log Site ID Enter a number from 00 to 99. The site ID will become part of the downloaded file name to help distinguish downloads from different instruments. Press ✓ to store the setting.
- Mode Select Velocity, LVT, Level or Flow. Press ✓ to store the setting.
- Set Date Press ↑ or ↓ to scroll and select Month, Day and Year. Press ✓ to store the setting.
- Set Time Press ↑ or ↓ to select the current time in Hours, Minutes and Seconds. Press ✓ to store the setting.
- Interval Press ↑ or ↓ to select the logging interval. Press ✓ to store the setting.
- Log Stop, Start or Delete the log file. Press ↑ or ↓ to Delete and ✓ to delete the log file. Press ↑ or ↓ to Start and ✓ to start the logger.

Note: You MUST delete old log and start a new log AFTER having set changes to Log Site ID, Mode and/or Interval for those changes to be applied to the log file.

View 24-hr formatted Reports on the AVFM 5.0 display. Press ◀ from the main display to view a formatted flow report from instruments with a built-in data logger. Press ◀ to pan through Level, Velocity and Flow summaries. Press ↓ to scroll down one day or repeatedly to scroll to a specific date. Up to 365 days can be stored. Newest date will overwrite the oldest. Press ✓ to return to the main display.

RETRIEVE LOG FILE

Plug a USB Flash Memory Drive (not supplied by Greyline) into the USB output cable from the instrument. The instrument display will show the USB file download icon until the log file is transferred to the memory card and then display file download completed icon. The USB flash drive may be removed.

Download file names will appear in this format:

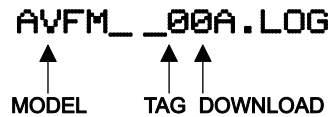

Tag is set according to the Log Site ID entered in the instrument Data Logging menu.

Download letter will be A for the first download from an instrument. B for the second, then C etc. At the letter Z a - character will appear indicating that the maximum number of downloads for that instrument are on the USB flash drive. Older files can be erased or moved from the flash memory drive or a new memory drive can be used.

OPENING LOG FILES

Install Greyline Logger on your PC or laptop. Refer to the Help menu in the program for detailed instructions.

Select File/Open/Instrument Log (.log) to open the log file from your USB flash drive.

SPECIFICATIONS

| | |
|-------------------------------------|--|
| Electronics Enclosure: | NEMA4X (IP 66), watertight and dust tight, polycarbonate with clear, shatterproof hinged Lexan cover |
| Accuracy: | Level: $\pm 0.25\%$ of Range Velocity: $\pm 2\%$ of Reading. Requires solids or bubbles minimum size of 100 microns, minimum concentration 75 ppm. Repeatability: 0.1% of Full Scale, Linearity: 0.1% of Full Scale |
| Display: | White, backlit matrix – displays flow rate, totalizer, relay states, operating mode and calibration menu |
| Programming: | Built-in 5-key calibrator with English, French or Spanish language selection |
| Power Input: | 100-240VAC, 50/60 Hz, (30 W max.) Optional 9-32VDC, rated 9W (typical 5.8W with standard features) |
| Outputs: | 3 Isolated 4-20mA, 1000 ohm load maximum or 3 Isolated 0-5V |
| Control Relays: | Qty 2, rated 5 ampere SPDT |
| Temperature Compensation: | Automatic, temperature probe built in to level Sensor |
| Electrical Surge Protection: | Sensor, 4-20mA, AC power input |
| Environmental Conditions: | Relative humidity up to 80% -23 to 60°C ambient temperature, maximum 5000 m altitude, pollution degree 4, Installation Category II. Optional Enclosure Heater recommended for condensation protection below 32°F (-1°C) |

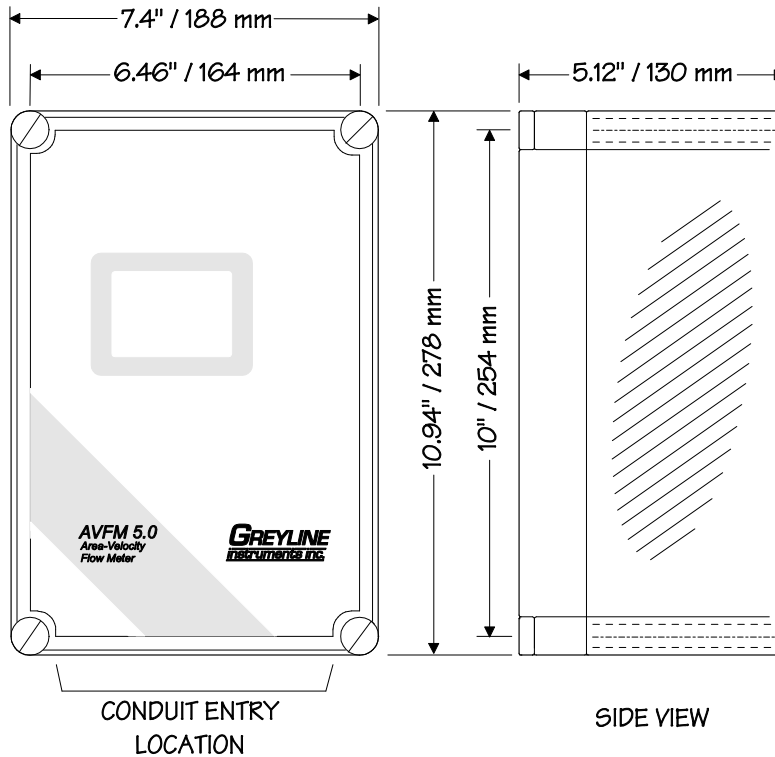

Velocity/Level Sensor QZ02L

| | |
|-------------------------------|---|
| Minimum Velocity: | 0.1 ft/sec (0.03 m/sec) |
| Maximum Velocity: | 20 ft/sec (6.2 m/sec) [reverse flow to -5 ft/sec (-1.5 m/sec)] |
| Minimum Head: | 1 in. (25.4 mm) |
| Maximum Head: | 16 ft. (4.88 m) |
| Operating Temperature: | 5 to 175°F (-15 to 80°C) |
| Exposed Materials: | 316 Stainless Steel, epoxy resin, polyurethane |
| Sensor Cable: | 26.25 ft. (8 m) submersible polyurethane jacket, shielded, 3 coaxial |
| Hazardous Rating: | CSA rated Intrinsically Safe Class I, Groups C,D, Class II, Groups E,F,G with optional Intrinsic Safety Barrier |

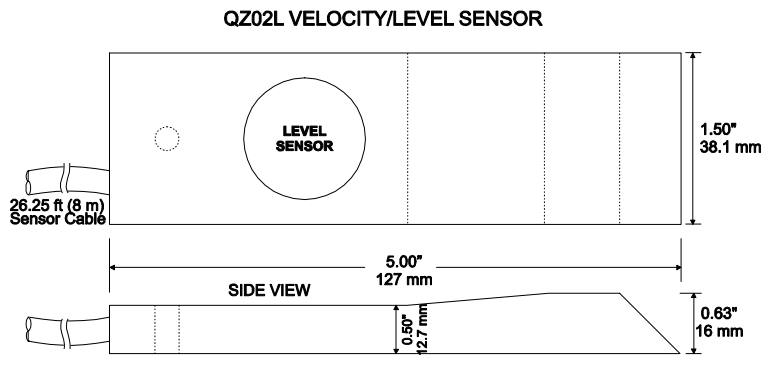
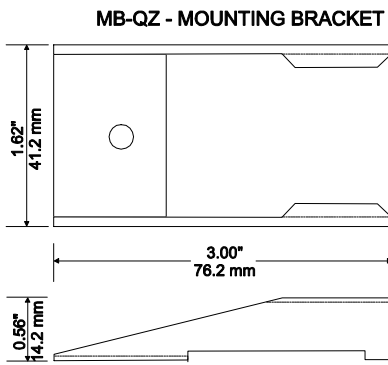

Optional (Velocity only) Sensor QZ02L-DP

- Minimum Velocity:** 0.1 ft/sec (0.03 m/sec)
- Maximum Velocity:** 20 ft/sec (6.2 m/sec) [reverse flow to -5 ft/sec (-1.5 m/sec)]
- Operating Temperature:** 5 to 150°F (-15 to 65°C)
- Exposed Materials:** PVC, epoxy resin, polyurethane, ultem
- Sensor Cable:** 26.25 ft (8 m) submersible polyurethane jacket, shielded, 3-coaxial
- Hazardous Rating:** CSA rated Intrinsically Safe Class I, Groups C,D, Class II, Groups E,F,G, with optional Intrinsic Safety Barrier

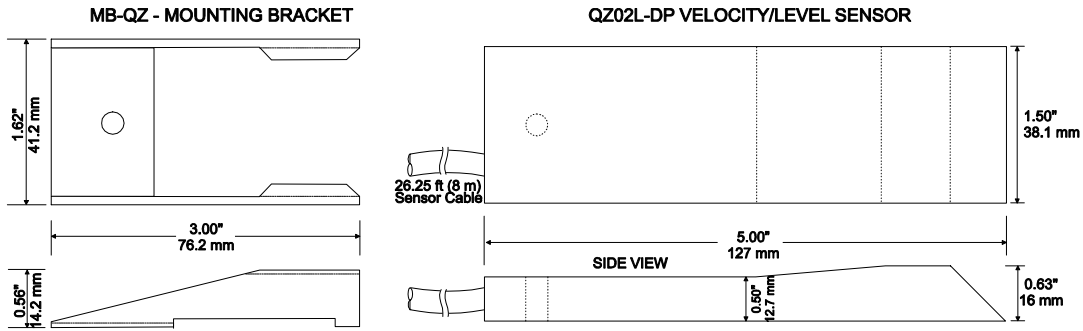

Optional Sensor PZ15-LP

- Maximum Range:** 15 ft (4.57 m)
- Minimum Range:** 8" (203.2 mm)
- Beam Angle:** 8°
- Operating Temperature:** -40 to 150°F (-40 to 65°C)
- Exposed Materials:** Sensor - PVC, Mounting Bracket - 316 Stainless
- Hazardous Rating:** CSA rated Intrinsically Safe Class I, Groups C,D, Class II, Groups E,F,G with optional Intrinsic Safety Barrier

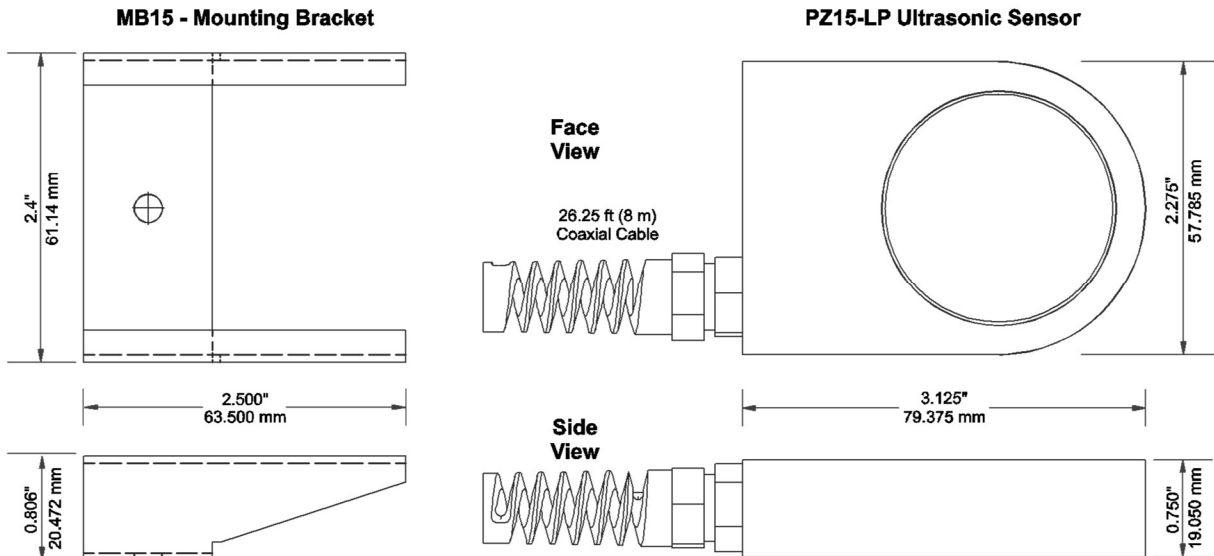

Dual Non-Contacting Sensor Configuration

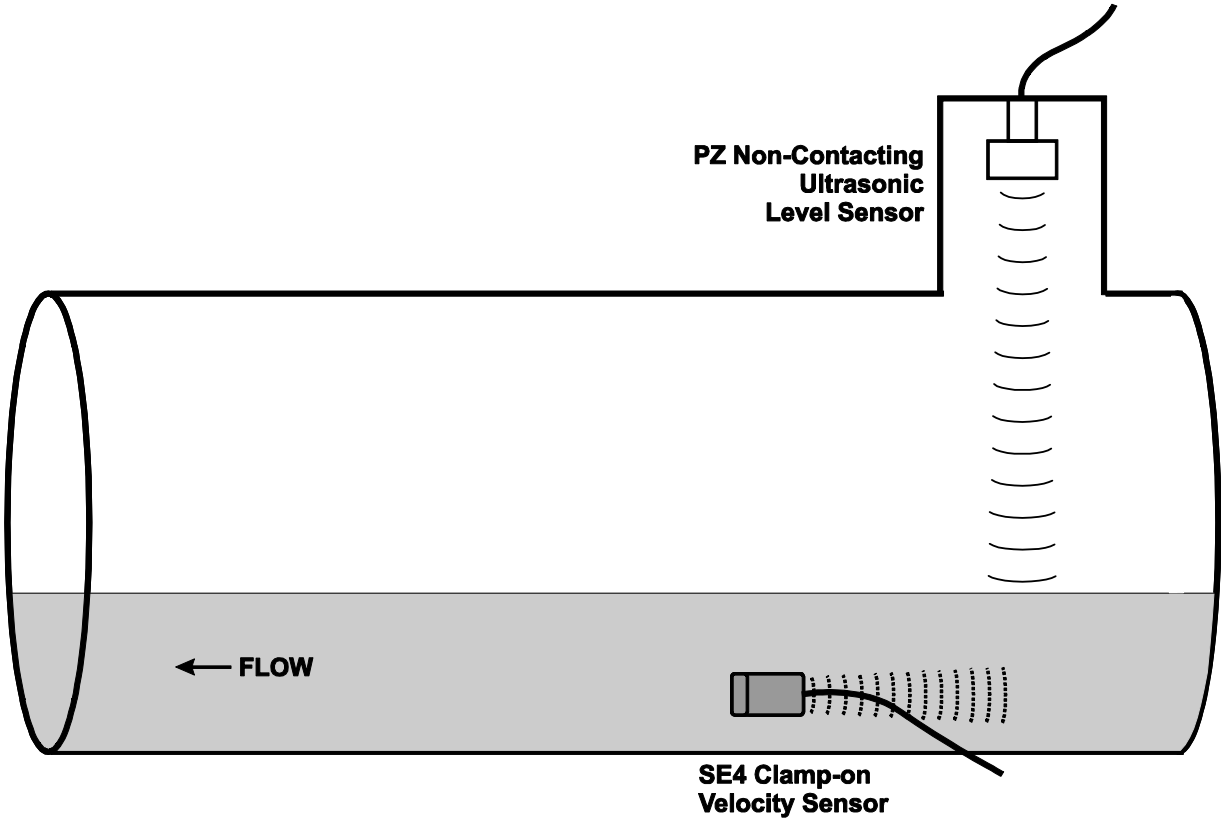

CONNECTIONS
Dual Sensor Configuration

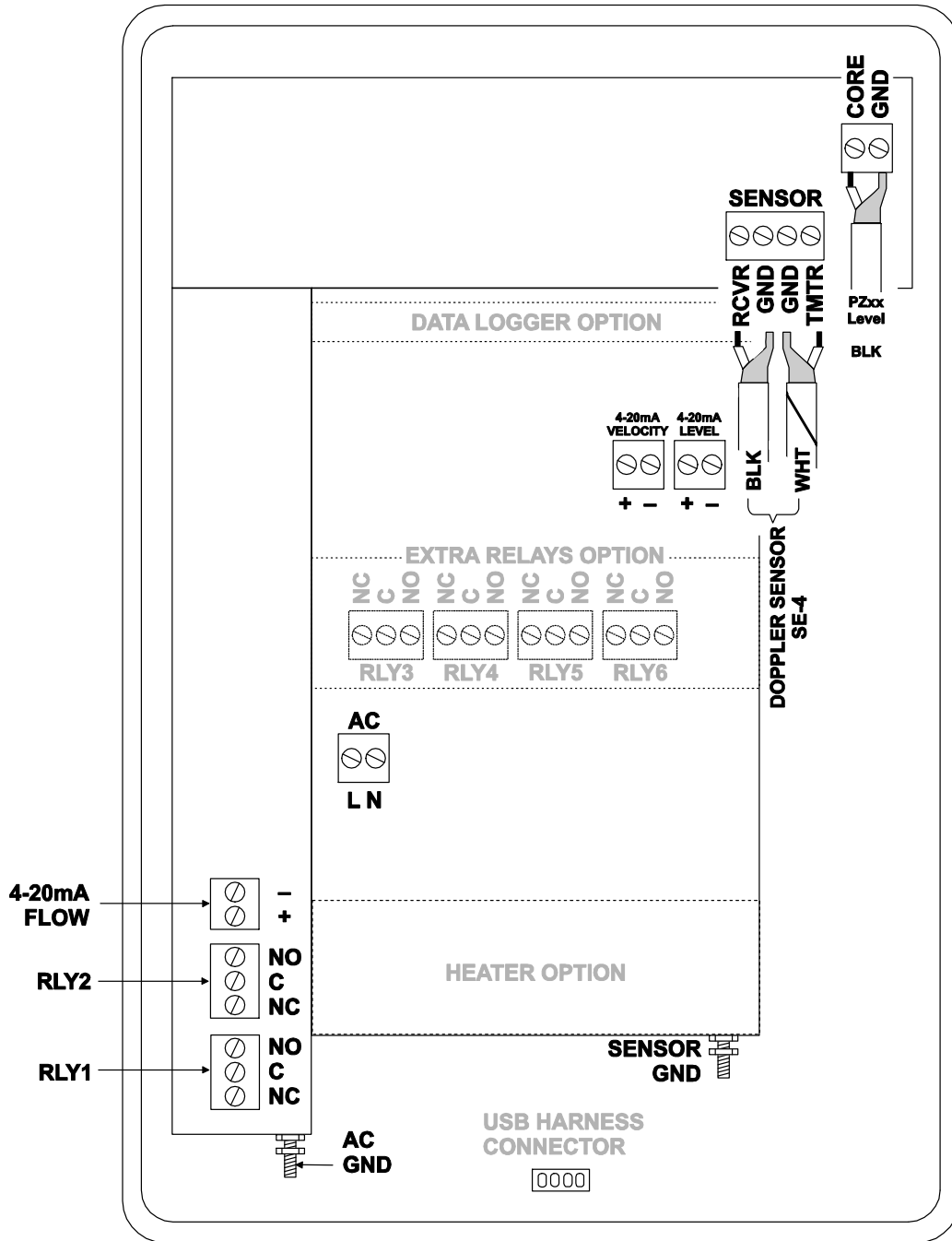

| --Calibration----- | |
|--------------------|--------------------------|
| ▶20mA Flo | 10.000ft ³ /s |
| 4mA Flo | 0.000ft ³ /s |
| 20mA Vel | 10.000 ft/s |
| 4mA Vel | 0.000 ft/s |
| 20mA Level | 12.000ft |
| 4mA Level | 0.000ft |
| Min Level | 0.000in |
| Lvl Offset | 0.000in |
| Min Vel | 0.000ft/s |
| Damping | 10% |

CALIBRATION

Non Contacting Level Sensor Configuration

Press **↓** to Calibration and **➡** to enter. Use **↓** or **↑** to position **▶** before each menu item and **➡** to enter. When settings are completed press **✓** to store and return to the Calibration menu.

20mA Flo [5V Flo] Press **➡** and enter the flow rate value for 20mA.

Note: Analogue output can be selected as 4-20mA or 0-5V in Special Functions.

4mA Flo [0V Flo] Press **➡** and enter the flow rate value for 4mA.

20mA Vel [5V Vel] Press **➡** and enter the velocity value for 20mA.

4mA Vel [0V Vel] Press **➡** and enter the velocity value for 4mA.

20mA Level [5V Level] Optional for QZ02L-A type sensor. Press **➡** and enter the level value for 20mA.

4mA Level [0V Level] Optional for QZ02L-A type sensor. Press **➡** and enter the level value for 4mA.

MaxRg Only for PZxx type sensor. Press **➡** and enter the zero water level (distance from the PZxx sensor to the zero water level).

MinRg

Only for PZxx type sensor. Press **➡** and enter the max level (distance from the PZxx sensor to the max water level).

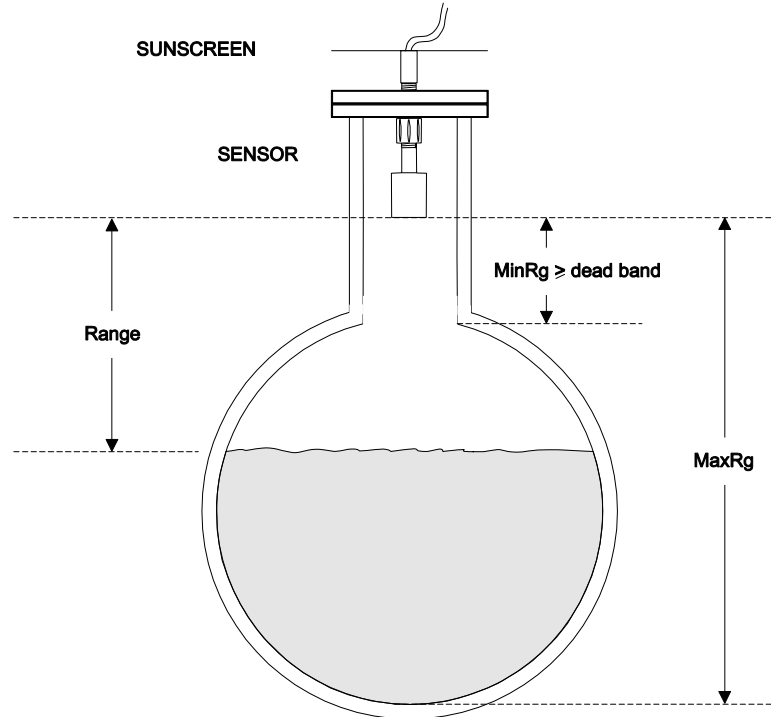

Min Vel

Press **➡** and enter a minimum velocity cutoff. Forward and reverse velocities less than Min Vel will be forced to zero.

Damping

Increase damping to stabilize readings under turbulent flow readings or to reject spurious level readings. Decrease for faster response to changes in flow.

Press **✓** from the Calibration display to return to Menu Selections.

PZxx FLANGE SENSOR MOUNTING METHODS IN ROUND PIPES

Notes:

1. Use the 3/4" NPT "Isolation Coupling" supplied and hand tighten only. Do not clamp sensor body or stem.
2. Do not mount sensor or cover flange in direct sunlight.
3. Extend sensor cable up to 500 ft (150 m) with RG62AU coaxial only and junction box.
4. Standpipe diameter as large as possible, typical standpipe: 6" / 150 mm diameter, 12" – 16" (300 – 500 mm) height.

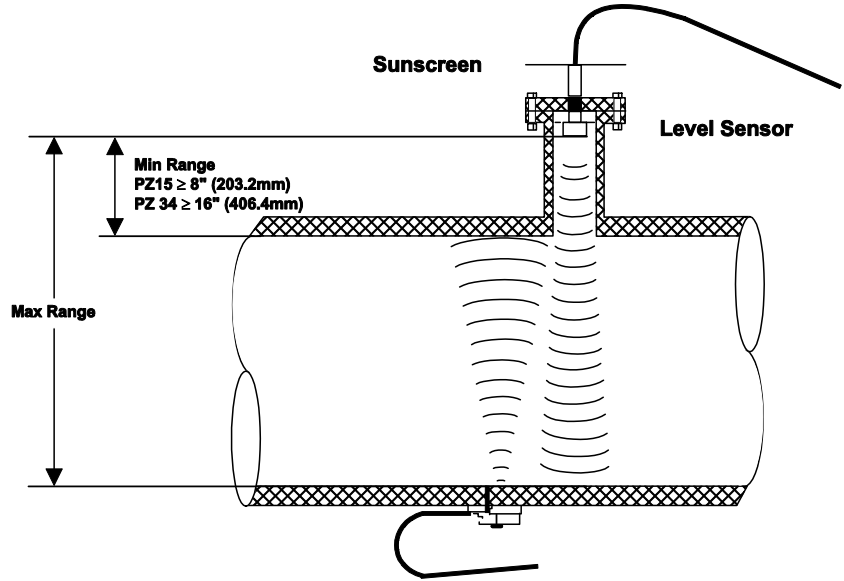

Use a Sensor Sunscreen (option PZS) when sensor is installed indirect sunlight.

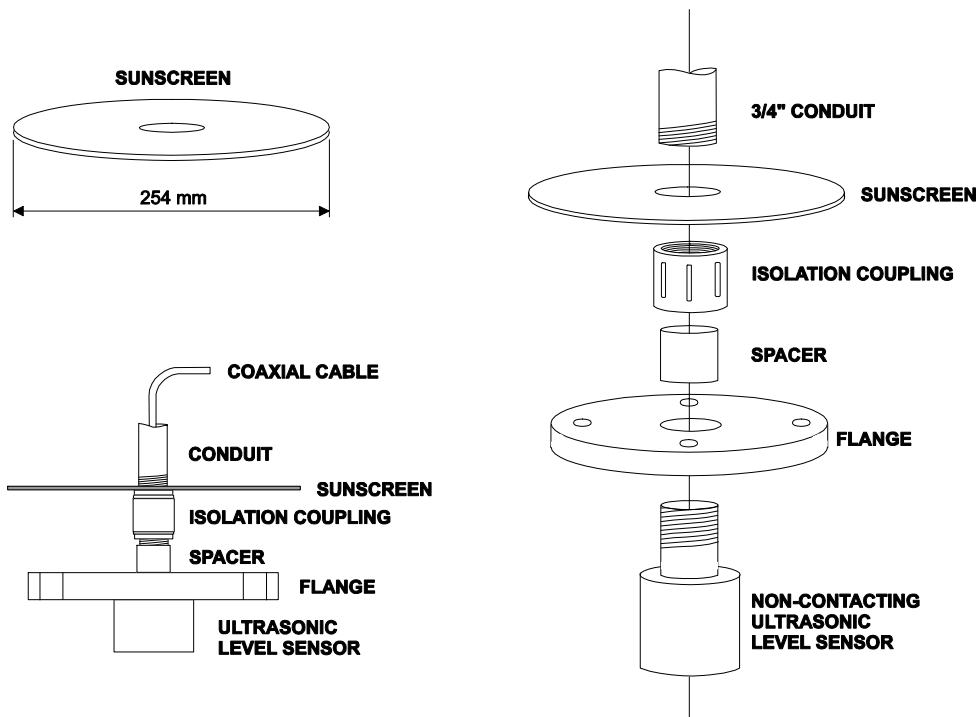

DOPLER VELOCITY SENSOR COUPLING **Dual Sensor Configuration**

For permanent or temporary bonding, the following are recommended:

- a) Dow Corning silicon compound #4 (supplied)
Additional supply: order Greyline Option CC
- b) High Temperature compound
Additional supply: order Greyline Option AP-1W
- c) Water-based sonic compound: Order Greyline Option CC30
- d) Electrocardiograph gel
- e) Petroleum gel (Vaseline)

The above are arranged in their order of preferred application.
d & e are only good for temporary bonding at room temperature.
DO NOT USE: Silicon RTV caulking compound (silicon rubber).

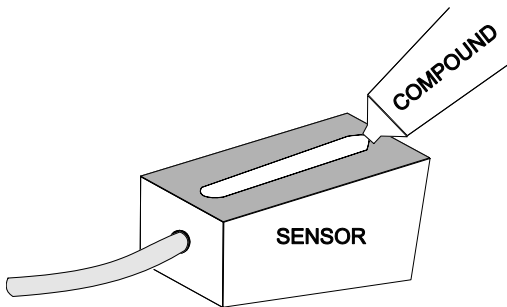

Use the PC4 pipe clamp (supplied) as illustrated above or use a loop of electrical tape for temporary mounting. Apply silicon coupling compound #4 to the coloured face of the sensor. A bead, similar to toothpaste on a toothbrush, is ideal. Do not overtighten (crush the sensor).

The sensor must be fixed securely to the pipe with coupling material between the sensor face and the pipe. Sensor installation with excessive coupling compound can result in gaps or voids in the coupling and cause errors or loss of signal. Insufficient coupling compound will create similar conditions.

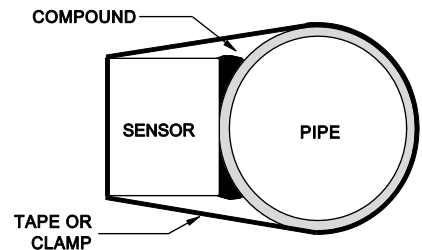

Over time temporary coupling compounds (e.g. Petroleum Gel) may gradually sag away from the sensor resulting in reduced signal strength and finally complete loss of signal. Warm temperatures, moisture and vibration will accelerate this process. Dow Corning Silicone Compound #4 as supplied with the AVFM 5.0 (and available from Greyline Instruments) is recommended for semi-permanent installations.

SENSOR MOUNTING

Dual Sensor Configuration

Prepare an area 2" wide by 4" long (50mm x 100mm) for sensor bonding by removing loose paint, scale and rust. The objective of site preparation is to eliminate any discontinuity between the sensor and the pipe wall, which would prevent acoustical coupling.

A PC4 Sensor Mounting Kit is supplied with each Greyline flow meter. It includes recommended coupling compound in a plastic applicator and a stainless steel mounting bracket with adjustable pipe straps.

END VIEW

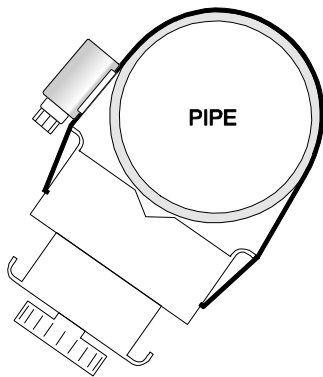

Additional stainless steel bands (by customer) may be combined to mount on pipes up to 180" / 4.5 m OD.

