



OPTITEMP TT 30 C/R Technical Datasheet

Intelligent two wire universal transmitter

- Cost effective, isolated and universal configurable for all type of sensors without recalibration
- Very well proven in use with high MTBF, more than 5 million hours
- Error correction feature for highest total accuracy



The documentation is only complete when used in combination with the relevant documentation for the sensor.

1	Product features	3
<hr/>		
1.1	The universal, programmable 2-wire temperature transmitter.....	3
1.2	Options and variants.....	5
1.3	Measuring principles.....	6
1.3.1	Resistance temperature sensor.....	6
1.3.2	Thermocouples.....	7
2	Technical data	8
<hr/>		
2.1	Technical data.....	8
2.2	Dimensions.....	13
2.3	Temperature data for potentially explosive areas.....	14
2.4	Output load diagram.....	15
2.5	Electrical data for outputs and inputs of the Ex versions.....	17
2.6	RTD and T/C accuracy table.....	18
3	Installation	20
<hr/>		
3.1	Notes on installation.....	20
3.2	Intended use.....	20
3.3	In-head transmitter (Ex and Non-Ex).....	21
3.4	Rail mounting kit for in-head transmitters.....	22
3.5	Rail-mount transmitter (Ex and Non-Ex).....	24
4	Electrical connections	25
<hr/>		
4.1	Safety instructions.....	25
4.2	Electrical input connections.....	25
4.2.1	In-head transmitter (Ex and Non-Ex).....	26
4.2.2	Rail-mount transmitter (Ex and Non-Ex).....	27
4.3	Electrical connection diagrams.....	28
4.3.1	In-head transmitter (Non-Ex).....	28
4.3.2	In-head transmitter (Ex).....	29
4.3.3	Rail-mount transmitter (Non-Ex).....	30
4.3.4	Rail-mount transmitter (Ex).....	31
5	Order information	32
<hr/>		
5.1	Order code.....	32
6	Notes	35
<hr/>		

1.1 The universal, programmable 2-wire temperature transmitter

The TT 30 is a universal, intelligent, programmable and isolated 2-wire transmitter for temperature, resistance or voltage measurements in an industrial environment.

The TT 30 series consists of 2 different versions in terms of the mounting. The TT 30 R is the rail-mount version whereas TT 30 C is primarily intended to be mounted in a "B connection head" or larger according to DIN 43729. As an alternative you can also mount the in-head version on a DIN rail according to DIN 50022 / EN 60715 with the help of an optionally available rail mounting kit.

The whole TT 30 transmitter series combines competitive pricing, functionality and simple configuration. Useful error correction functions like the automatic correction of known sensor errors improve the accuracy.

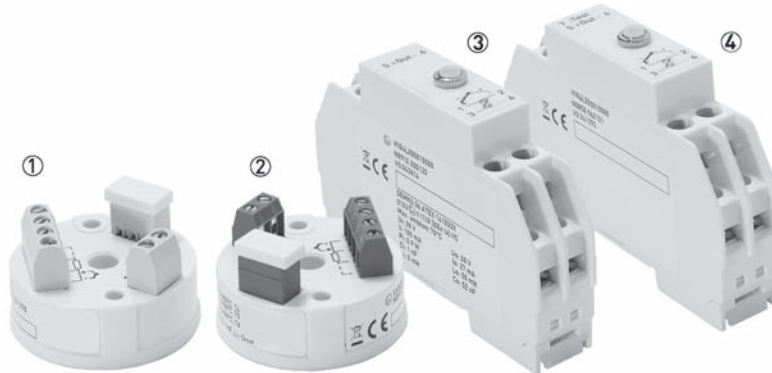

- ① In-head transmitter (Non-Ex version)
- ② In-head transmitter (Ex version)
- ③ Rail-mount transmitter (Ex version)
- ④ Rail-mount transmitter (Non-Ex version)

Highlights

- Fully universal, linearized and highly isolated
- Accepts RTD, TC, mV and Ω
- SmartSense feature allows low sensor isolation detection (only for TT 30 C)
- Sensor break monitoring
- Sensor error correction and system error correction for highest total accuracy
- Full access to all features while in operation
- NAMUR compliant
- Simplified loop check-up with calibration output
- Test output without breaking the loop (only for rail-mounted Non-Ex)
- TempSoft, easy-to-use Windows configuration software
- In-head version optionally available in an intrinsically safe version for installation in hazardous areas (zone 0, 1 and 2) . Rail mounted version optionally available in an intrinsically safe version for installation into safe area and input connection to hazardous areas (zone 0, 1 and 2).

Industries

- Chemicals
- Oil & Gas
- Power industry
- Iron, Steel & Metal
- Pulp & Paper
- Food & Beverage
- Pharmaceuticals

1.2 Options and variants

In-head transmitter (TT 30 C)



The in-head version distinguishes itself by an easy wiring and the large centre hole. The housing is extremely durable and facilitates easy connections. The transmitter is optionally available in an intrinsically safe version for installation in potentially explosive areas. The nameplate of these transmitters has an "Ex" symbol (TT 30 C Ex), they are approved for use in zone 0, 1 and 2.

There are two different installation situations for the in-head version. Primarily it is intended to be mounted in a "B connection head" or larger according to DIN 43729. As an alternative you can also mount it on a DIN rail according to DIN 50022 / EN 60715 with the help of an optionally available rail mounting kit.

Rail-mount transmitter (TT 30 R)



The distinctive feature of the rail-mount version is its simplified loop check-up with calibration output. It is intended for installation on a top-hat rail according to DIN 50022.

Also the rail-mount version is optionally available in an intrinsically safe version for connection to a sensor placed in potentially explosive areas. The nameplate of these transmitters has an "Ex" symbol (TT 30 R Ex), they are approved for installation into non-hazardous area and may be connected to a temperature sensor placed in potentially explosive areas in zone 0, 1 and 2.

1.3 Measuring principles

The kind of the measuring principle depends on the measuring insert that you combine with the transmitter. In matters of the thermometer type the manufacturer offers two different measuring inserts, either with a resistance thermometer or with a thermocouple. For more information refer to the handbook of the measuring inserts or the handbook of the industrial thermometers.

1.3.1 Resistance temperature sensor

The measuring insert with a temperature-sensitive sensor made from a platinum RTD, whose value at 0°C / +32°F is 100 Ω. That is where the name "Pt100" comes from.

It is generally valid that the electric resistance of metals increases according to a mathematical function as the temperature rises. This effect is taken advantage of by resistance temperature sensors to measure temperature. The "Pt100" temperature sensors features a measuring resistance with defined characteristics, standardised in IEC 60751. The same is true for the tolerances. The average temperature coefficient of a Pt100 is $3.85 \times 10^{-3} \text{ K}^{-1}$ in the range from 0...+100°C / +32...+212°F.

During operation, a constant current $I (\leq 1 \text{ mA})$ flows through the Pt100 RTD, which brings about a voltage drop U . The resistance R is calculated using Ohm's Law ($R=U/I$). As the voltage drop U at 0°C / +32°F is 100 mV, the resulting resistance of the Pt100 temperature assembly is 100 Ω (100 mV / 1 mA = 100 Ω).

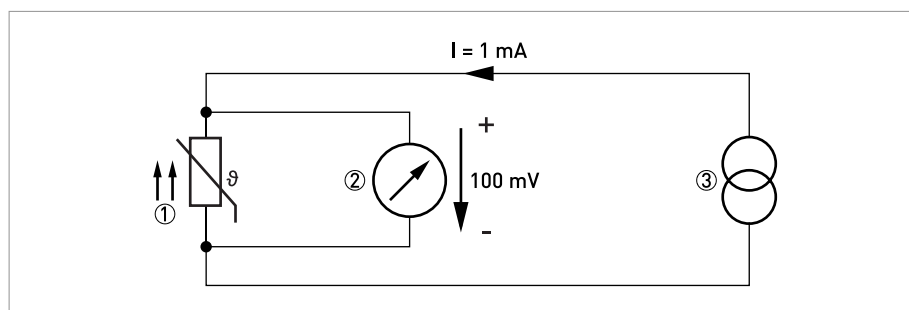

Figure 1-1: Pt100 resistance temperature sensor in 4-wire connection at 0°C / +32°F, schematic.

- ① Pt100 RTD
- ② Voltage meter
- ③ Current source

1.3.2 Thermocouples

The thermocouple features two electric conductors made from different metals, connected at one end. Each free end is connected to a compensation cable which is then connected to a millivolt meter. This circuitry forms a "thermal circuit". The point at which the two electric conductors connect is called the measuring point and the point at which the compensation cables connect to the conductors of the millivolt meter is called the cold junction.

If the measuring point of this thermal circuit is heated up, a small electrical voltage (thermal voltage) can be measured. If, however, the measuring point and the cold junction are at the same temperature, no thermoelectric voltage is generated. The degree of thermoelectric voltage, also known as electromotive force (EMF), depends on the thermocouple material and the extent of the temperature difference between the measuring point and the cold junction. It can be measured using the millivolt meter with no auxiliary power.

Simply put, the thermocouple behaves like a battery, the voltage of which also increases as the temperature rises.

The characteristic curves and tolerances of commercially available thermocouples are standardised in IEC 60584.

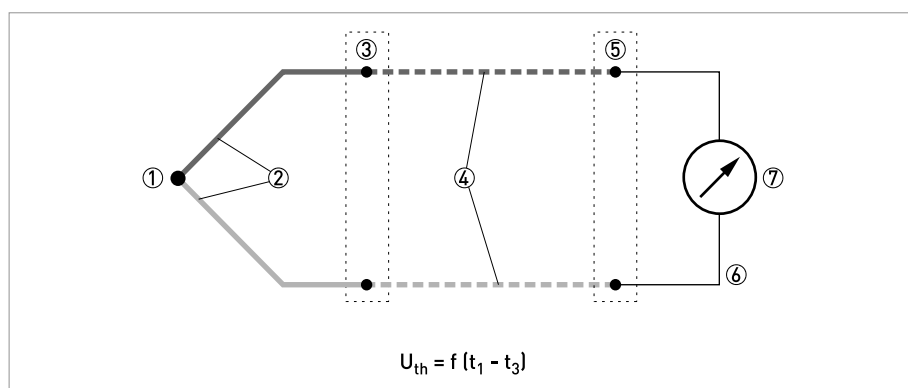

Figure 1-2: Thermocouple measuring circuit, schematic.

- ① Measuring point t_1 (hot junction)
- ② Thermocouple
- ③ Transition junction t_2
- ④ Compensation cable / extension cable
- ⑤ Reference junction t_3 (cold junction)
- ⑥ Copper conductor
- ⑦ Voltage meter U_{th}

2.1 Technical data

- *The following data is provided for general applications. If you require data that is more relevant to your specific application, please contact us or your local sales office.*
- *Additional information (certificates, special tools, software,...) and complete product documentation can be downloaded free of charge from the website (Downloadcenter).*

Measuring system

Application range	Temperature, resistance or voltage measurements of solids, liquids and gases in an industrial environment.
-------------------	--

Design

Versions	
TT 30 C	In-head transmitter which is optionally available in an intrinsically safe version for installation in potentially explosive areas of zone 0, 1 and 2.
TT 30 R	Rail-mount transmitter which is optionally available in an intrinsically safe version for connection to sensors installed in potentially explosive areas of zone 0, 1 and 2.
Special features	
Sensor error correction	This function automatically corrects known sensor errors; the precondition is that you have entered these known sensor errors (e.g. the deviation of a calibrated sensor from the standard curve).
System error correction	This function corrects the system error (sensor error + transmitter error); the precondition is that the sensor has been exposed to one (one-point correction) or two (two-point correction) accurately measured temperatures ("true temperatures"); after you have entered these true temperature(s), the transmitter automatically corrects these errors afterwards.
Sensor isolation monitoring / SmartSense (only for TT 30 C)	This function continuously monitors the isolation resistance of thermocouples and 3-wire connected RTDs as well as the cabling between sensor and transmitter; if the isolation is too low, the transmitter forces the output to a user-defined level; note that SmartSense requires an extra lead inside the thermocouple or RTD. User-definable output: $\leq 3.6 \text{ mA}$, $\geq 21 \text{ mA}$ or customized
Customized linearization	A customized linearization with 9 linearization points is available for the transmitter. It can be used to create almost any type of linearization curve for RTD, T/C, resistance and mV inputs (the curve must be monotonic increasing).
Sensor break monitoring	This function monitors sensor break and forces the output signal to a user-defined level if any sensor lead is broken or disconnected, for RTD input it will also detect sensor short circuit. The monitoring is furnished with a pulsed excitation current which eliminates the voltage drop on the lead wires, the sensor break monitoring can be switched off. User-definable output: $\leq 3.6 \text{ mA}$, $\geq 21 \text{ mA}$ or customized
Controlled output for instrument calibration	You can set the transmitter to automatically provide a recurring output current regardless of the input signal; the total time for the controlled output is adjustable up to 30 minutes.
Dampening	This function dampens undesired instabilities on the input signal; the dampening time is the time required for the output to reach 90% of its final value after a step change has been applied to the input (in addition to the update time); it is ca. 2 seconds.
Loop check-up	The transmitter works as an accurate current generator.

Measuring accuracy

Accuracy	RTD and thermocouple: for detailed information refer to <i>RTD and T/C accuracy table</i> on page 18.
	Typically $\pm 0.1\%$ of input span: <ul style="list-style-type: none"> • RTD: Max. of $\pm 0.2^\circ\text{C}$ / $\pm 0.4^\circ\text{F}$ or $\pm 0.1\%$ • Resistance / potentiometer: Max. of ± 0.1 Ohm or $\pm 0.1\%$ • Voltage and thermocouple: Max. of $\pm 20\ \mu\text{V}$ or $\pm 0.1\%$
Linearity	RTD, resistance / potentiometer and voltage: $\pm 0.1\%$
	Thermocouple: $\pm 0.2\%$
Temperature influence	RTD and thermocouple: for detailed information refer to <i>RTD and T/C accuracy table</i> on page 18.
	Resistance and voltage: $\pm 0.01\%$ of span per $^\circ\text{C}$ and $\pm 0.006\%$ of span per $^\circ\text{F}$
Cold Junction Compensation (CJC)	In-head transmitter: $\pm 0.5^\circ\text{C}$ at ref. conditions (23°C) $\pm 0.9^\circ\text{F}$ at ref. conditions (73°F)
	Rail-mount transmitter: $\pm 0.5^\circ\text{C}$ at ref. conditions (23°C) $\pm 0.9^\circ\text{F}$ at ref. conditions (73°F)
Temperature influence (all inputs)	Reference temperature: 23°C / 73°F
	Max. of $\pm 0.25\%$ of input span per 25°C or $\pm 0.25^\circ\text{C}$ of input span per 25°C
	Max. of $\pm 0.28\%$ of input span per 50°F or $\pm 0.5^\circ\text{F}$ of input span per 50°F
	Note that if zero-deflection $> 100\%$ of input span, you have to add 0.125% of input span per 25°C or 0.14% of input span per 50°F per 100% zero-deflection.
Temperature influence CJC (Thermocouple)	Reference temperature: 23°C / 73°F
	$\pm 0.5^\circ\text{C}$ per 25°C / $\pm 1.0^\circ\text{F}$ per 50°F
Instrument calibration output	$4\text{...}20\ \text{mA}$, $\pm 8\ \mu\text{A}$
Sensor wire resistance influence	RTD and resistance / potentiometer, 3-wire connection: negligible, with equal wire resistance
	RTD and resistance / potentiometer, 4-wire connection: negligible
	Thermocouple and voltage: negligible
Load influence	Negligible
Supply voltage influence	Negligible
RFI influence	In-head transmitter: typically $\pm 0.1\%$ of input span ($0.15\text{...}80\ \text{MHz}$, $10\ \text{V}$ / $80\text{...}1000\ \text{MHz}$, $10\ \text{V/m}$)
	Rail-mount transmitter: typically $\pm 0.2\%$ of input span ($0.15\text{...}80\ \text{MHz}$, $10\ \text{V}$ / $80\text{...}1000\ \text{MHz}$, $10\ \text{V/m}$)
Long-term drift	Max. $\pm 0.1\%$ of input span per year

Operating conditions

Temperature	
In-head transmitter	Non-Ex version: $-40\text{...}+85^\circ\text{C}$ / $-40\text{...}+185^\circ\text{F}$ (operating and storage temperature)
	Ex version: $-40\text{...}+85^\circ\text{C}$ / $-40\text{...}+185^\circ\text{F}$ (storage temperature), for detailed information about the ambient temperatures refer to <i>Temperature data for potentially explosive areas</i> on page 14.
Rail-mount transmitter	Non-Ex version: $-20\text{...}+70^\circ\text{C}$ / $-4\text{...}+158^\circ\text{F}$ (operating and storage temperature)
	Ex version: $-20\text{...}+70^\circ\text{C}$ / $-4\text{...}+158^\circ\text{F}$ (operating and storage temperature)
Humidity	$5\text{...}95\%$ relative humidity (non-condensing)
Protection category	

In-head transmitter	Housing: IP50
	Terminals: IP10
Rail-mount transmitter	Housing: IP20
	Terminals: IP20

Installation conditions

Mounting	In-head transmitter: "B connection head" or larger according to DIN 43729; with the help of the rail mounting kit you can also fix this transmitters on a DIN rail according to DIN 50022 / EN 60715.
	Rail-mount transmitter: rail according to DIN 50022 / EN 60715, 35 mm / 1.38".
	For detailed information refer to chapter "Installation".
Weight	In-head transmitter (Ex and Non-Ex version): 50 g / 0.11 lb
	Rail-mount transmitter (Ex and Non-Ex version): 70 g / 0.15 lb
Dimensions	For detailed information refer to <i>Dimensions</i> on page 13.
Materials	
Housing	In-head transmitter: PC + ABS, Polyamide for all versions
	Rail-mount transmitter: PC + Glass fibre for all versions
Flammability acc. to UL	In-head transmitter: V0 (PC + ABS) and V2 (Polyamide)
	Rail-mount transmitter: V0 (PC + glass fibre)

Electrical connections

Power supply	
In-head transmitter	Non-Ex version: 6.5...36 VDC (2-wire connection)
	Ex version: 8...30 VDC (2-wire connection)
Rail-mount transmitter	Non-Ex version: 7.5...36 VDC (2-wire connection)
	Ex version: 8...30 VDC (2-wire connection)
Current consumption	≤ 21,6 mA
Permissible ripple	4 V p-p at 50/60 Hz
Further data	
Galvanic isolation	1500 VAC, 1 min
	All inputs and outputs are electrically isolated from each other and from all other circuits.
Connection	Single/stranded wires: max. 1.5 mm ² / AWG 16
Polarity protection	Standard for all versions

Inputs / outputs

Zero adjustment (all inputs)	Any value within the range limits.
Input - RTD	
Pt100 (IEC 60751, $\alpha = 0.00385$)	-200...+1000°C / -328...+1832°F (3- and 4-wire connection)
Pt100 (ASTM 1137-97, $\alpha = 0.003902$)	
Pt100 (JIS C1604-1981, $\alpha = 0.003916$)	
Pt1000 (IEC 60751, $\alpha = 0.00385$)	-200...+200°C / -328...+392°F (3- and 4-wire connection)
D100 (Pt100 according to JIS1604, $\alpha = 0.003916$)	-200...+1000°C / -328...+1832°F (3- and 4-wire connection)
PtX ($10 \leq X \leq 1000$) (IEC 60751, $\alpha = 0.00385$)	The upper range depends on the X value (3- and 4-wire connection), max. input temperature corresponding to 2000 Ω.
Ni100 (DIN 43760)	-60...+250°C / -76...+482°F (3- and 4-wire connection)
Ni120 (Edison No. 7)	
Ni1000 (DIN 43760)	-100...+150°C / -148...+302°F (3- and 4-wire connection)
Cu10 (Edison No. 15)	-200...+260°C / -328...+500°F
Minimum span	10°C / 18°F (Pt100/1000, Ni100/1000)
Sensor current	Approx. 0.4 mA
Maximum sensor wire resistance	25 Ω / wire
Input - resistance / potentiometer	
Range (resistance)	0...2000 Ω
Range (potentiometer)	0...2000 Ω (3- and 4-wire connection)
Minimum span	10 Ω
Sensor current	Approx. 0.4 mA
Customized linearization	9 points
Maximum sensor wire resistance	25 Ω / wire
Input - thermocouples	
T/C type C - W5Re-W26Re	-10...+2300°C / 14...+4172°F
T/C type B - Pt30Rh-Pt6Rh (IEC 60584)	0...+1800°C / +32...+3272°F
T/C type E - NiCr-CuNi (IEC 60584)	-200...+1000°C / -328...+1832°F
T/C type J - Fe-CuNi (IEC 60584)	-200...+1000°C / -328...+1832°F
T/C type K - NiCr-NiAl (IEC 60584)	-200...+1350°C / -328...+2462°F
T/C type L - Fe-CuNi (DIN 43710)	-200...+900°C / -328...1652°F
T/C type N - NiCrSi-NiSiMg (IEC 60584)	-270...+1300°C / -454...+2372°F
T/C type R - Pt13Rh-Pt (IEC 60584)	-50...+1750°C / -58...+3182°F
T/C type S - Pt10Rh-Pt (IEC 60584)	-50...+1750°C / -58...+3182°F
T/C type T - Cu-CuNi (IEC 60584)	-200...+400°C / -328...+752°F
T/C type U - Cu-CuNi (DIN 43710)	-200...+600°C / -328...+1112°F
Voltage	-10...+500 mV
Minimum span	2 mV

Input impedance	>10 M Ω
Maximum wire loop resistance	500 Ω (total loop)
Cold Junction Compensation (CJC)	Internal or none (0°C)
Input - voltage	
Range	-10...+500 mV
Minimum span	2 mV
Customized linearization	Up to 9 points
Input impedance	>10 M Ω
Maximum wire loop resistance	500 Ω (total loop)
Output	
Output signal	4...20 mA, 20...4 mA or customized; temperature, resistance or voltage linear, customized linearization possible.
	Span: 3.8...20.5 mA (measurement), 3.5...21.6 mA (failure)
	Resolution: 5 μ A
Update time	Approx. 1.5 seconds
Selectable dampening time	0 or 2 s (time constant)
NAMUR compliance	Current limitations and failure currents acc. to NAMUR NE 43
Configuration	
TempSoft	The PC configuration software, TempSoft, is a versatile and user-friendly tool for transmitter configuration, loop check-up and sensor diagnostics. It runs on Windows 2000, XP, Vista and Windows 7.

Approvals and certifications

CE	The device fulfils the statutory requirements of the EC directives. The manufacturer certifies that these requirements have been met by applying the CE marking.
Ex approvals	
Non-Ex version	Without
ATEX	Intrinsically safe according to ATEX Directive 94/9/EC harmonized standards In-head transmitter: EN 60079-0:2006, EN 60079-11:2007 and EN 60079-26:2007. Rail-mount transmitter: EN 60079-0:2006, EN 60079-11:2007
Electromagnetic compatibility	Directive: 2004/108/EC
	Harmonized standards according to EN 61326-1:2006
Vibration resistance	Acc. to IEC 60068-2-6; tested: In-head: 10 g, 60...2000 Hz, Rail: 5 g, 60...500 Hz
Shock resistance	Acc. to IEC 60068-2-31, tested for Drop and Topple, IEC 60068-2-31
NAMUR	Output limitations and fail currents according to NAMUR recommendations.

2.2 Dimensions

In-head transmitter

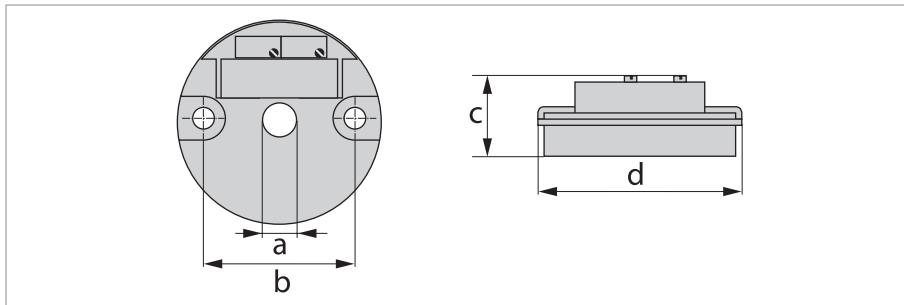

	Dimensions	
	[mm]	[inch]
a	44	1.73
b	26	1.02
c	16	0.63
d	7	0.28
e	33	1.30

Rail-mount transmitter

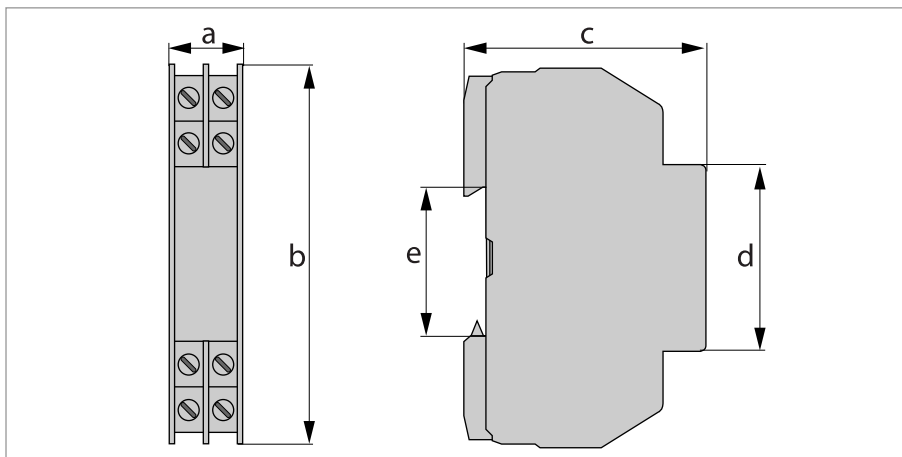

	Dimensions	
	[mm]	[inch]
a	17.5	0.69
b	90	3.54
c	58	2.28
d	45	1.77
e	35	1.38

2.3 Temperature data for potentially explosive areas

In-head transmitter (Ex version)

Temperature class	Ambient temperature T_a
T6	$-40^{\circ}\text{C} \leq T_a \leq +50^{\circ}\text{C}$ / $-40^{\circ}\text{F} \leq T_a \leq +122^{\circ}\text{F}$
T5	$-40^{\circ}\text{C} \leq T_a \leq +65^{\circ}\text{C}$ / $-40^{\circ}\text{F} \leq T_a \leq +149^{\circ}\text{F}$
T4	$-40^{\circ}\text{C} \leq T_a \leq +85^{\circ}\text{C}$ / $-40^{\circ}\text{F} \leq T_a \leq +185^{\circ}\text{F}$

2.4 Output load diagram

In-head transmitter (Non-Ex)

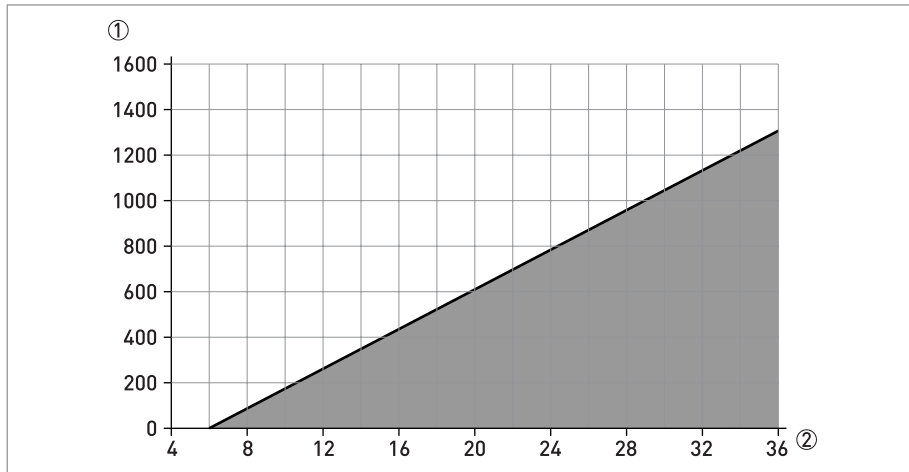

① Total output load R_{Load} [Ω]

② Supply voltage U [VDC]

Formula for the maximum permissible output load of the in-head version (Non-Ex):
 permissible R_{Load} [Ω] = $(U - 6.5) / 0.022$

In-head transmitter (Ex)

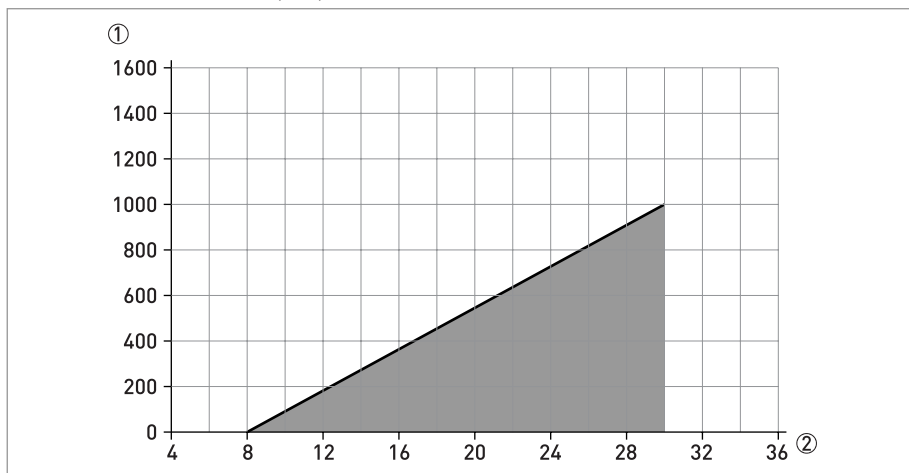

① Total output load R_{Load} [Ω]

② Supply voltage U [VDC]

Formula for the maximum permissible output load of the in-head version (Ex):
 permissible R_{Load} [Ω] = $(U - 8.0) / 0.022$

Rail-mount transmitter (Non-Ex)

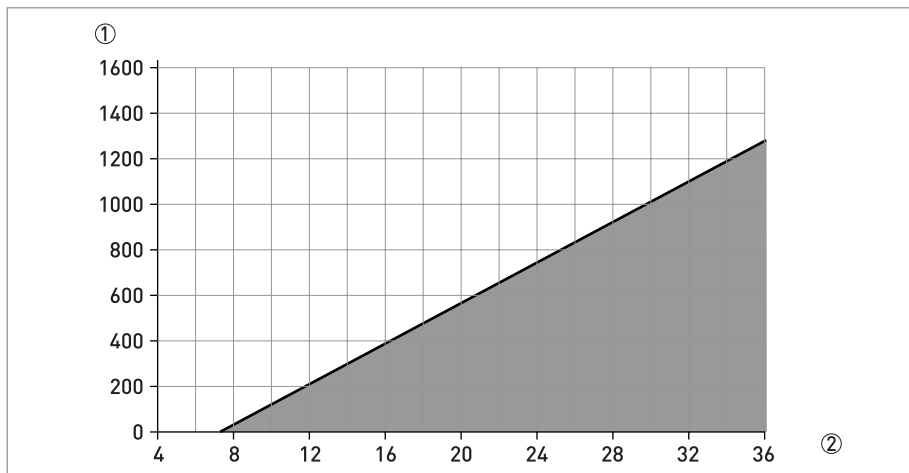

- ① Total output load R_{Load} [Ω]
- ② Supply voltage U [VDC]

Formula for the maximum permissible output load of the rail-mount version:
 permissible R_{Load} [Ω] = (U-7.5)/0.022

Rail-mount transmitter (Ex)

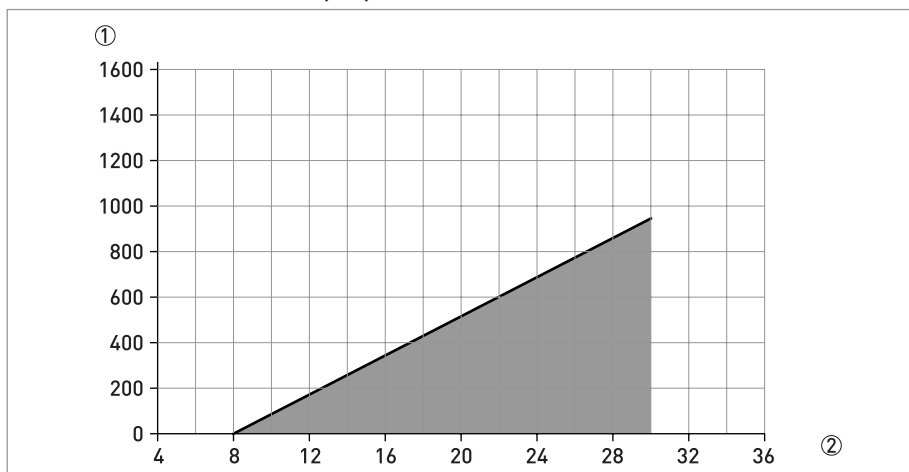

- ① Total output load R_{Load} [Ω]
- ② Supply voltage U [VDC]

Formula for the maximum permissible output load of the rail-mount version (Ex):
 permissible R_{Load} [Ω] = (U-8.0)/0.022

2.5 Electrical data for outputs and inputs of the Ex versions

In-head transmitter (Ex version)

Output terminals 5, 6 ①		Input terminals 1, 2, 3, 4 ②	
Max. voltage to transmitter	$U_i = 30 \text{ VDC}$	Max. voltage from transmitter	$U_o = 30 \text{ VDC}$
Max. current to transmitter	$I_i = 100 \text{ mA}$	Max. current from transmitter	$I_o = 25 \text{ mA}$
Max. power to transmitter	$P_i = 900 \text{ mW}$	Max. power from transmitter	$P_o = 188 \text{ mW}$
Internal inductance	$L_i \sim 0 \text{ mH}$	Max. inductance (input loop)	$L_o \sim 50 \text{ mH}$
Internal capacitance	$C_i \sim 1 \text{ nF}$	Max. capacitance (input loop)	$C_o \sim 66 \text{ nF}$

Rail-mount transmitter (Ex version)

Output terminals 5, 6 ①		Input terminals 1, 2, 3, 4 ②	
Max. voltage to transmitter	$U_i = 30 \text{ VDC}$	Max. voltage from transmitter	$U_o = 30 \text{ VDC}$
Max. current to transmitter	$I_i = 100 \text{ mA}$	Max. current from transmitter	$I_o = 27 \text{ mA}$
Max. power to transmitter	$P_i = 900 \text{ mW}$	Max. power from transmitter	Not specified
Internal inductance	$L_i \sim 0 \text{ mH}$	Max. inductance (input loop)	$L_o \sim 50 \text{ mH}$
Internal capacitance	$C_i \sim 1 \text{ nF}$	Max. capacitance (input loop)	$C_o \sim 52 \text{ nF}$

① Current loop

② Intrinsically safe sensor connection

2.6 RTD and T/C accuracy table

Conformance level 95% (2σ)

CJC = Cold Junction Compensation

Accuracies in °C

Input type	Temp. range [°C]	Min. span [°C]	Max. accuracy	Max. temp. influence (dev. from ref. temp. 23°C)
RTD Pt100	-200...+1000	10	Max. of $\pm 0.2^\circ\text{C}$ or $\pm 0.1\%$ of input span ①	Max. of $\pm 0.01^\circ\text{C}$ per $^\circ\text{C}$ or $\pm 0.01\%$ of input span per $^\circ\text{C}$ ②
RTD Pt1000	-200...+200			
RTD PtX ③	-200...max. input temp (corresp. to 2 k Ω)			
RTD Ni100	-60...+250			
RTD Ni120	-70...+300			
RTD Ni1000	-100...+150			
RTD Cu10	-200...+260			
RTD Pt100 ($\alpha = 0.003902$)	-200...+1000	10		
RTD Pt100 ($\alpha = 0.003916$)	-200...+1000			
T/C type B	0...+1800	Corresp. to 2 mV		
T/C type C	-10...+2300			
T/C type E	-200...+1000			
T/C type J				
T/C type K	-200...+1350			
T/C type L	-200...+900			
T/C type N	-270...+1300			
T/C type R	-50...+1750			
T/C type S				
T/C type T	-200...+400			
T/C type U	-200...+600			
T/C custom	-10...+500 mV			

① Linearity error is not included

② If zero-deflection is $> 100\%$ of input span then you have to add 0.005% of input span per $^\circ\text{C}$ per 100% zero-deflection!

③ ($10 \leq X \leq 1000$)

④ Linearity error and CJC error is not included

⑤ Temp. influence CJC is not included; also note that if zero-deflection is $> 100\%$ of input span: add 0.005% of input span per $^\circ\text{C}$ per 100% zero-deflection!

Accuracies in °F

Input type	Temp. range [°F]	Min. span [°F]	Max. accuracy	Max. temp. influence (dev. from ref. temp. 73°C)
RTD Pt100	-328...+1832	18	Max. of $\pm 0.4^{\circ}\text{C}$ or $\pm 0.1\%$ of input span ①	Max. of $\pm 0.01^{\circ}\text{F}$ per $^{\circ}\text{F}$ or $\pm 0.006\%$ of input span per $^{\circ}\text{F}$ ②
RTD Pt1000	-328...+392			
RTD PtX ③	-328...max. input temp (corresp. to 2 k Ω)			
RTD Ni100	-76...+482			
RTD Ni120	-94...+572			
RTD Ni1000	-148...+302			
RTD Cu10	-328...+500	180		
RTD Pt100 ($\alpha = 0.003902$)	-328...+1832	18		
RTD Pt100 ($\alpha = 0.003916$)				
T/C type B	+32...+3272	Corresp. to 2 mV	$\pm 20 \mu\text{V}$ or $\pm 0.1\%$ of input span ④	$\pm 0.01^{\circ}\text{F}$ per $^{\circ}\text{F}$ or $\pm 0.006\%$ of input span per $^{\circ}\text{F}$ ⑤
T/C type C	+14...+4172			
T/C type E	-328...+1832			
T/C type J				
T/C type K	-328...+2462			
T/C type L	-328...+1652			
T/C type N	-454...+2372			
T/C type R	-58...+3182			
T/C type S				
T/C type T	-328...+752			
T/C type U	-328...+1112			
T/C custom	-10...+500 mV			

① Linearity error is not included

② If zero-deflection is > 100% of input span then you have to add 0.003% of input span per $^{\circ}\text{F}$ per 100% zero-deflection!

③ ($10 \leq X \leq 1000$)

④ Linearity error and CJC error is not included

⑤ Temp. influence CJC is not included; also note that if zero-deflection is > 100% of input span then you have to add 0.003% of input span per $^{\circ}\text{F}$ per 100% zero-deflection!

3.1 Notes on installation

Inspect the packaging carefully for damages or signs of rough handling. Report damage to the carrier and to the local office of the manufacturer.

Do a check of the packing list to make sure that you have all the elements given in the order.

Look at the device nameplate to ensure that the device is delivered according to your order.

3.2 Intended use

You may only use transmitters labelled with the "Ex" symbol in potentially explosive areas or connect them to a sensor located in those areas. Additionally always note the zone(s) for which the devices have an approval. Otherwise the transmitters might cause an explosion that can result in fatal injuries.

Responsibility for the correct use of the devices with special regard to suitability, intended use and the field of application lies solely with the operator. To avoid any kind of incorrect use, also note the information in the chapter "Device description".

The transmitters do not contain any serviceable parts inside. Any substitution of components may impair the intrinsic safety of the versions with an Ex approval. Always send defective devices to the manufacturer or the local distributor for repair or exchange. If this is the case, attach a clear description of the malfunction for warranty claims.

The manufacturer is not liable for any damage resulting from improper use or use for other than the intended purpose. To avoid any kind of incorrect use, also note the information in the chapter "Device description"!

The manufacturer has constructed these transmitters for usage in an industrial environment and for the following measurements:

- Temperature measurements with resistance thermometers
- Temperature measurements with thermocouples
- Temperature difference measurements with resistance thermometers
- Voltage measurements in a range up to 500 mV
- Measurements with potentiometers

3.3 In-head transmitter (Ex and Non-Ex)

Never install or operate the Non-Ex version in potentially explosive areas, it might cause an explosion that can result in fatal injuries! Only use the Ex version in potentially explosive areas! Also note the following items which concern the Ex version:

- *It must be installed in a housing that has the protection category IP20 or better according to DIN IEC 60529. Additionally the magnesium component of the housing must not exceed 6% as a higher magnesium component may increase the flammability and the Ex capability.*
- *If it is mounted in a housing which is isolated from the ground and can be charged to an ignition capable level, then the housing must be electrostatically grounded when installed in hazardous areas.*
- *It is approved for potentially explosive areas in zone 0, 1 and 2.*
- *It must be supplied by an intrinsically safe power supply unit or a Zener barrier placed outside of the potentially explosive area.*

The manufacturer has developed the Non-Ex version for an operating temperature range of -40...+85°C / -40...+185°F (the Ex version has the same ambient temperature range). To avoid destruction or damage of the device, always assure that the operating temperature or the ambient temperature does not exceed the permissible range and note the following items:

- *If you operate the Ex version in potentially explosive areas, the ambient temperature also depends on the temperature class. For detailed information refer to the section about the temperature data for potentially explosive areas on page 14.*
- *The thermowell also transfers the process temperature to the transmitter housing. If the process temperature is close to or exceeds the maximum temperature of the transmitter, then the temperature in the transmitter housing can rise above the maximum permissible temperature!*

One way to decrease the heat transfer via the thermowell is to install the transmitter farther away from the heat source. An alternative is to make the thermowell longer. Inversely you can take similar measures if the temperature is below the specified minimum temperature.

The in-head transmitters (Ex and Non-Ex version) are intended for installation in DIN B connection heads or larger. The large Ø7 mm / 0.28" center hole facilitates the electrical connection of the measurement sensor and the installation (for detailed information refer to the chapter "Dimensions and weights"). The following drawing shows the installation of the in-head transmitter with the help of the connection head installation kit:

The connection head installation kit does not belong to the standard scope of delivery of the transmitter, you have to order it separately.

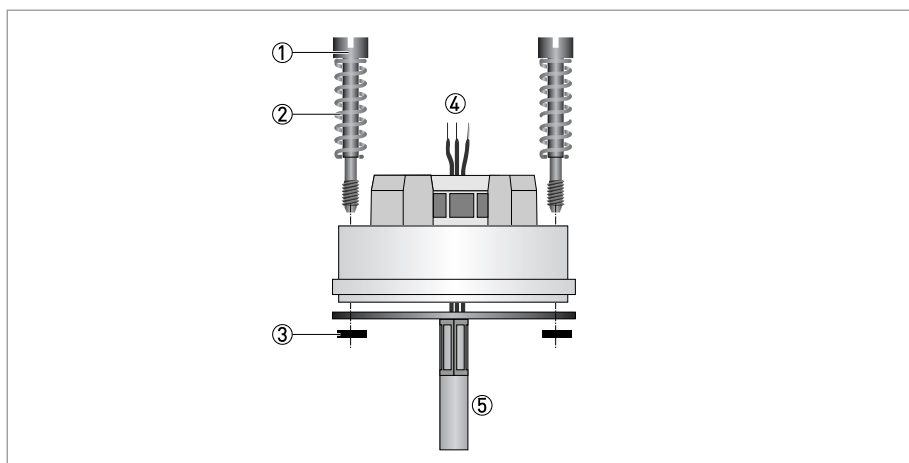

Figure 3-1: Connection head installation kit

- ① M4 screw
- ② Spring
- ③ Lock washer
- ④ Wires of measuring insert
- ⑤ Sheath

3.4 Rail mounting kit for in-head transmitters

To avoid fatal injuries, destruction or damage of the transmitter, always note the relevant admonitions in the previous section if you install the in-head-transmitter on a rail!

The rail mounting kit allows to install the in-head transmitter on a rail according to EN 60715 TH35. The kit does not belong to the standard scope of delivery, you have to order it separately. For more information refer to the section about the accessory parts in the chapter "Service".

Rail mounting kit for in-head transmitters

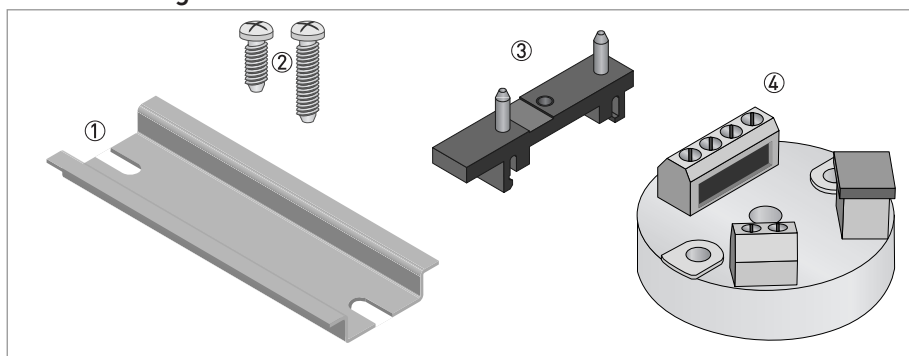

- ① Rail (not included in the kit)
- ② Screws
- ③ Clamp
- ④ Transmitter (not included in the kit)

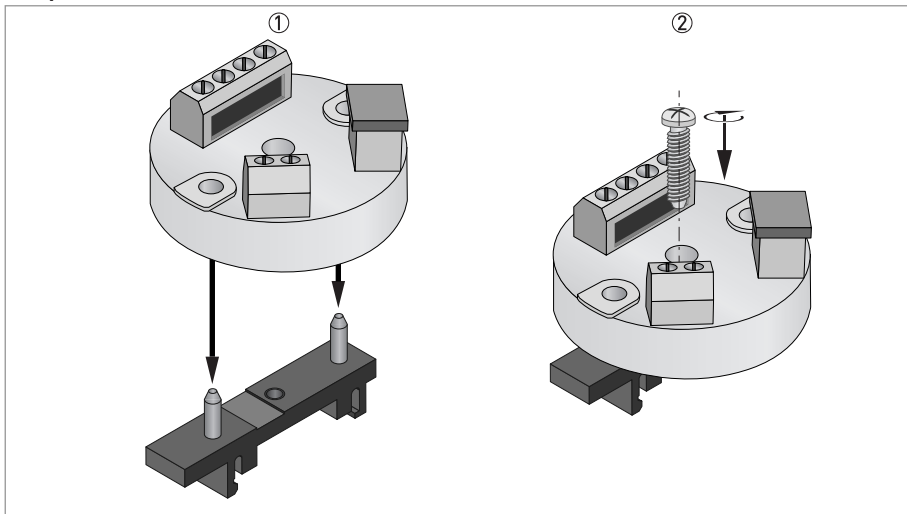
Step 1

- ① Place the transmitter on the clamp as shown above.
- ② Push the transmitter down until it reaches the plate and secure with a screw.

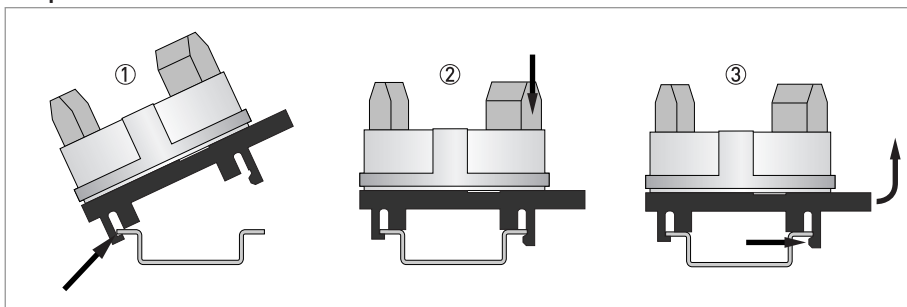
Step 2

- ① Hook one end of the clamp into the rail as shown above.
- ② Push the other end of the the kit down until it snaps onto the rail.
- ③ Release by pushing the hook, shown in the picture, and at the same time lift the clip out of the rail.

3.5 Rail-mount transmitter (Ex and Non-Ex)

Never install or operate the Non-Ex version in potentially explosive areas, it might cause an explosion that can result in fatal injuries! The rail-mounted transmitter TT 30 R Ex must NOT be mounted in potentially hazardous area BUT might be connected to classified hazardous location! Also note the following items which concern the Ex version:

- It is approved for mounting into safe, non-hazardous area with the input connected to potentially explosive area, zone 0, 1 and 2.
- It must be supplied by an intrinsically safe power supply unit or a Zener barrier placed outside of the potentially explosive area.

The manufacturer has developed the Non-Ex version for an operating temperature range of $-20...+70^{\circ}\text{C}$ / $-4...+158^{\circ}\text{F}$ (the Ex version has the same ambient temperature range). To avoid destruction or damage of the device, always note the following items:

- Assure that the operating temperature or the ambient temperature does not exceed the permissible range.

The rail-mount transmitter is intended for installation on a rail according to EN 60715 TH35.

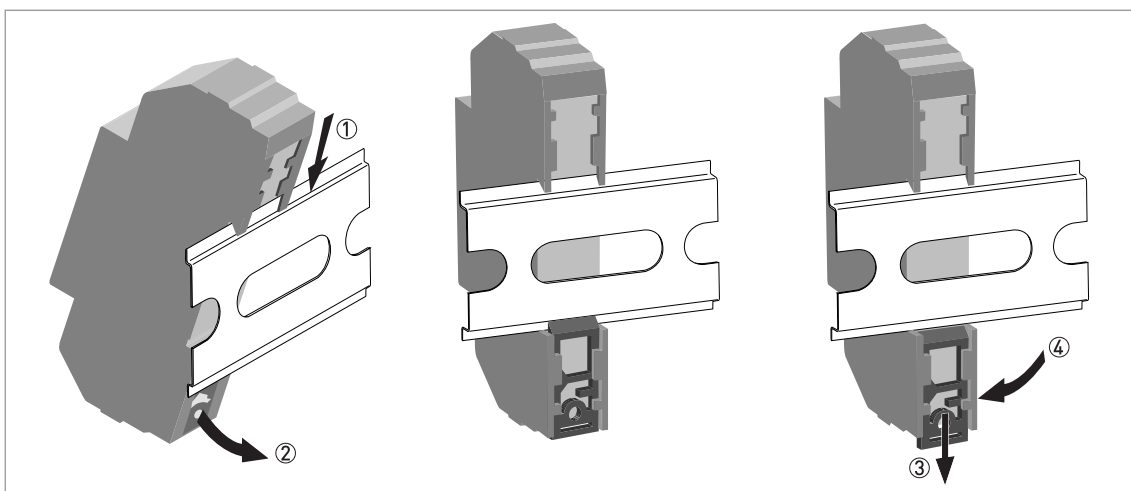

Figure 3-2: Installation of the rail-mount version

- ① Hook the upper groove of the transmitter onto the rail.
- ② Press the lower part of the transmitter against the rail.
- ➡ When you hear a "click" from the snap fastener, the transmitter is fixed onto the rail (drawing in the centre).
- ③ To remove the transmitter, use a small screwdriver to push the snap fastener downwards.
- ④ Carefully move the lower part of the transmitter in the forward direction and then upwards.

4.1 Safety instructions

All work on the electrical connections may only be carried out with the power disconnected.

Observe the national regulations for electrical installations!

Before you connect and operate a transmitter, always note the following items to avoid an electric shock:

- *For all work on the electrical connections use an electrostatic safe (i.e. grounded) workplace! In this way you minimize the risk of electrostatic discharge (ESD).*
- *Assure that the all removable covers were closed after any work on the device to protect it from dirt.*
- *Maximum common-mode voltage on the input is restricted to 50 VAC / 75 VDC.*

Never connect or operate a non-Ex version of a transmitter in potentially explosive areas, otherwise it might cause an explosion that can result in fatal injuries! Before you connect and operate a transmitter version with an Ex approval, always note the following items to avoid an explosion which may result in fatal injuries:

- *Connect the Ex version only to Ex approved sensors or sensors that meet the requirements for "simple apparatus" in EN 60079-11:2007, section 5.7.*
- *Observe the corresponding regulations, the declaration of conformity, the type test certificate of the device and the relevant instructions of this document.*

Observe without fail the local occupational health and safety regulations. Any work done on the electrical components of the measuring device may only be carried out by properly trained specialists.

Look at the device nameplate to ensure that the device is delivered according to your order.

The transmitter is protected against polarity reversal. No damage will occur to the device if the polarity of the supply voltage is switched. The output will then indicate 0 mA.

4.2 Electrical input connections

Always establish the electrical connections according to the following diagrams. Otherwise it can come to destruction or damage of the transmitter.

To avoid measuring errors, assure that all cables are connected properly and that the screws are tightened correctly.

4.2.1 In-head transmitter (Ex and Non-Ex)

"Isolation input/output/PC" as shown in section "Technical data" only shows the signal isolation. This is not an intrinsically safe galvanic isolation, which can be interpreted as an isolating barrier. Therefore particular care should be applied when selecting the barriers for the TT 30 C Ex.

Electrical input connections of the in-head transmitter

Pt100...1000, Ni100, Ni1000, 4-wire connection	Pt100...1000, Ni100, Ni1000, 3-wire connection
Pt100 "SmartSense", 3-wire connection ③	Pt100, temperature difference, $T_1 > T_2$ ④
Potentiometer, 4-wire connection	Potentiometer, 3-wire connection
Thermocouple	Voltage

- ① SmartSense wire
- ② Maximum input
- ③ Not for rail-mount transmitter
- ④ Differential value > 5 Ω or select "Sensor break = None"

4.2.2 Rail-mount transmitter (Ex and Non-Ex)

"Isolation input/output/PC" as shown in section "Technical data" only shows the signal isolation. This is not an intrinsically safe galvanic isolation, which can be interpreted as an isolating barrier. Therefore particular care should be applied when selecting the barriers for the TT 30 R Ex.

Electrical input connections of the rail-mount transmitter

Pt100...1000, Ni100, Ni1000, 4-wire connection	Pt100...1000, Ni100, Ni1000, 3-wire connection
Pt100, temperature difference, $T_1 > T_2$ ②	Potentiometer, 4-wire connection
Potentiometer, 3-wire connection	Thermocouple
Voltage	

① Maximum input

② Differential value $> 5 \Omega$ or select "Sensor break = None"

4.3 Electrical connection diagrams

Always establish the electrical connections according to the following diagrams. Otherwise it can come to destruction or damage of the transmitter.

4.3.1 In-head transmitter (Non-Ex)

Neither operate this transmitter in potentially explosive areas, nor connect it to a sensor located in a potentially explosive area! Otherwise the transmitter might cause an explosion that can result in fatal injuries!

Note that the maximum output load always depends on the power supply. If the maximum output load is exceeded, then the measured value will become incorrect. For further information refer to the output load diagrams in the chapter "Technical data".

The transmitter has a polarity protection. Connecting the power supply with a wrong polarity will not damage the transmitter.

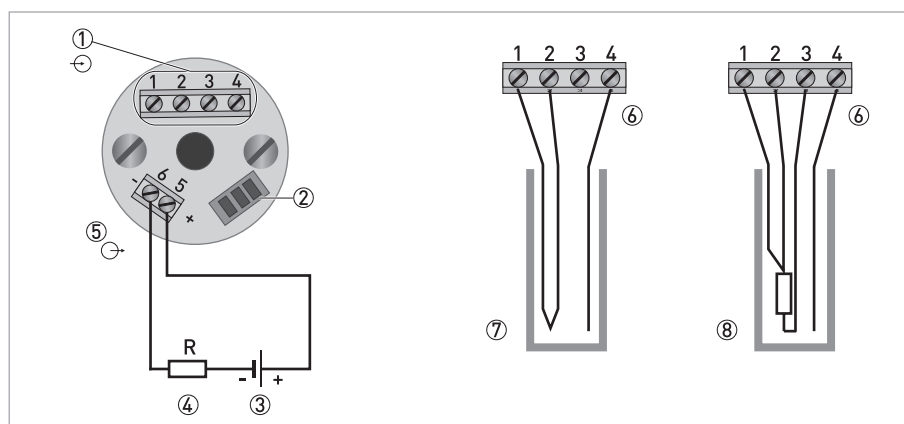

Figure 4-1: Connection diagram of the in-head transmitter (Non-Ex)

- ① Input
- ② Terminal for PC connection cable (contained in configuration set)
- ③ Power supply (6.5...36 VDC)
- ④ Load resistance
- ⑤ Output signal (4...20 mA)
- ⑥ SmartSense temperature sensor
- ⑦ Thermocouple
- ⑧ Pt100, 3-wire connection

4.3.2 In-head transmitter (Ex)

The Ex transmitter can be installed in potentially explosive areas of zone 0, 1 and 2. It may only be connected to Ex approved sensors or sensors that meet the requirements for "simple equipment" in EN 60079-11:2007, section 5.7. During operations in potentially explosive areas always note the relevant safety instructions and especially the following items:

- The transmitter must be supplied by an intrinsically safe power supply unit or Zener barrier placed outside of the potentially explosive area.
- The output parameters of the Ex approved Zener barrier or voltage supply have to be less or equal than the input parameters of the transmitter (i.e. U_i , I_i , P_i , L_i , C_i).

Note that the maximum output load always depends on the power supply. If the maximum output load is exceeded, then the measured value will become incorrect. For further information refer to the output load diagrams in the chapter "Technical data".

The transmitter has a polarity protection. Connecting the power supply with a wrong polarity will not damage the transmitter.

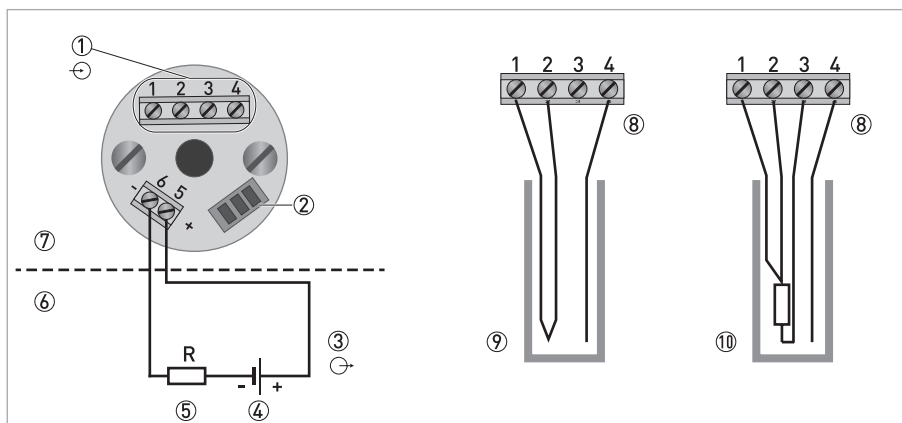

Figure 4-2: Connection diagram of the in-head transmitter (Ex)

- ① Input
- ② Terminal for PC connection cable (contained in configuration set)
- ③ Output signal (4...20 mA)
- ④ Intrinsically safe power supply (8...30 VDC)
- ⑤ Load resistance
- ⑥ Safe area
- ⑦ Potentially explosive area
- ⑧ SmartSense temperature sensor
- ⑨ Thermocouple
- ⑩ Pt100, 3-wire connection

4.3.3 Rail-mount transmitter (Non-Ex)

Neither operate this transmitter in potentially explosive areas, nor connect it to a sensor located in a potentially explosive area! Otherwise the transmitter might cause an explosion that can result in fatal injuries!

Note that the maximum output load always depends on the power supply. If the maximum output load is exceeded, then the measured value will become incorrect. For further information refer to the output load diagrams in the chapter "Technical data".

The transmitter has a polarity protection. Connecting the power supply with a wrong polarity will not damage the transmitter.

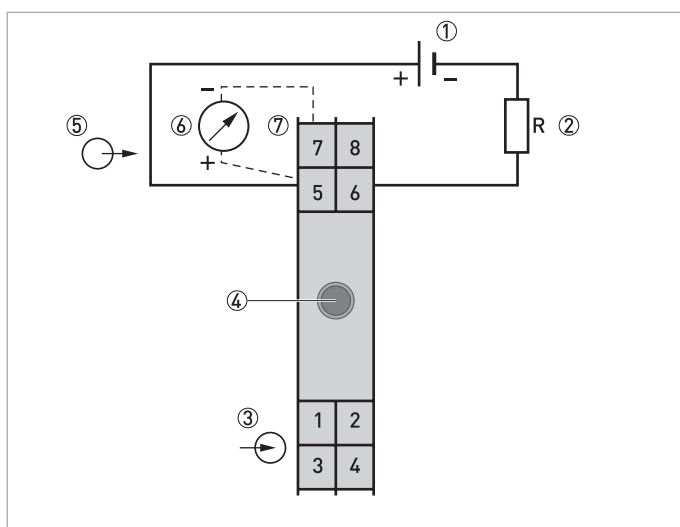

Figure 4-3: Connection diagram of the rail-mount transmitter (Non-Ex)

- ① Power supply (7.5...36 VDC)
- ② Load resistance
- ③ Input
- ④ Female connector for PC connection cable (contained in configuration set)
- ⑤ Output signal (4...20 mA)
- ⑥ Measuring device ($R_I \leq 10 \Omega$)
- ⑦ Test circuit (mA)

4.3.4 Rail-mount transmitter (Ex)

The Ex transmitter can be connected to temperature sensors installed in potentially explosive areas of zone 0, 1 and 2. It may only be connected to Ex approved sensors or sensors that meet the requirements for "simple equipment" in EN 60079-11:2007, section 5.7. During operations with the input signal connected to potentially explosive areas always note the relevant safety instructions and especially the following items:

- The transmitter must be supplied by an intrinsically safe power supply unit or Zener barrier placed outside of the potentially explosive area.
- The output parameters of the Ex approved Zener barrier or voltage supply have to be less or equal than the input parameters of the transmitter (i.e. U_i , I_i , P_i , L_i , C_i).

Note that the maximum output load always depends on the power supply. If the maximum output load is exceeded, then the measured value will become incorrect. For further information refer to the output load diagrams in the chapter "Technical data".

The transmitter has a polarity protection. Connecting the power supply with a wrong polarity will not damage the transmitter.

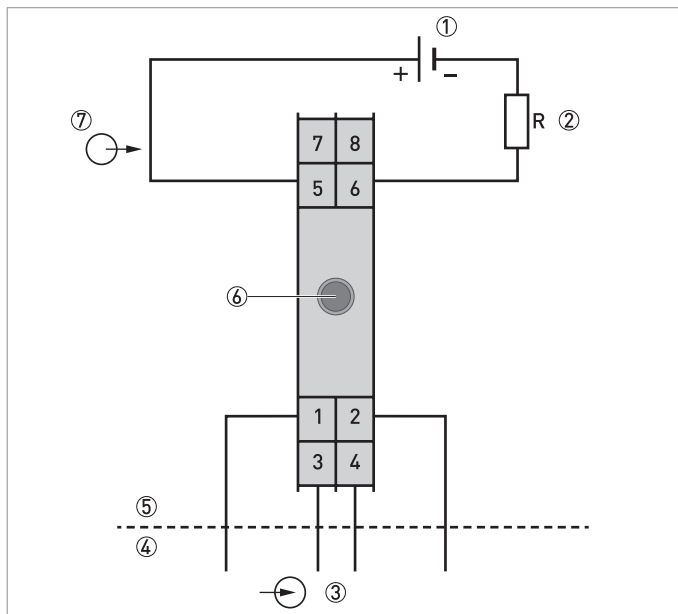

Figure 4-4: Connection diagram of the rail-mount transmitter (Ex)

- ① Intrinsically safe power supply (8...30 VDC)
- ② Load resistance
- ③ Input
- ④ Potentially explosive area
- ⑤ Safe area
- ⑥ Female connector for PC connection cable (contained in configuration set)
- ⑦ Output signal (4...20 mA)

5.1 Order code

The characters of the order code highlighted in light grey describe the standard.

VTT1	4	Design
	1	Head mounting (type C)
	2	DIN-rail mounting, 35 mm / 1.38" (type R)
		Type
	B	TT 30, digital, standard, 4...20 mA
		Approvals
	0	Without
	1	ATEX: II 1G Ex ia 11C T4-T6 (only for type C)
	5	ATEX: II (1) G [Ex ia] 11C (only for type R)
		Sensor
	0	Without
	1	Pt 10
	2	Pt 50
	3	Pt100 ($\alpha = 0.00385$)
	4	Pt100 ($\alpha = 0.003902$)
	5	Pt100 ($\alpha = 0.003916$)
	8	Pt1000 ($\alpha = 0.00385$)
	A	Potentiometer
	B	Thermocouple type B
	C	Thermocouple type C
	E	Thermocouple type E
	H	Thermocouple type J
	K	Thermocouple type K
	L	Thermocouple type L
	N	Thermocouple type N
	R	Thermocouple type R
	S	Thermocouple type S
	T	Thermocouple type T
	U	Cu 10
	V	Ni 50
	W	Ni 100
	X	Ni 120
	Y	Ni 1000
	Z	Customized
VTT1	4	Continued on next page

									Wiring
									0 Without
									2 2-wire (1 x sensor)
									3 3-wire (1 x sensor)
									4 4-wire (1 x sensor)
									A 3-wire Smart Sense
									Measuring range
									0 Without
									1 -50...+50°C / -58...+122°F
									2 -50...+100°C / -58...+212°F
									3 -50...+150°C / -58...+302°F
									4 0...+50°C / +32...+122°F
									5 0...+100°C / +32...+212°F
									6 0...+150°C / +32...+302°F
									7 0...+200°C / +32...+392°F
									8 0...+250°C / +32...+482°F
									A 0...+300°C / +32...+572°F
									B 0...+350°C / +32...+662°F
									C 0...+400°C / +32...+752°F
									D 0...+450°C / +32...+842°F
									E 0...+500°C / +32...+932°F
									F 0...+600°C / +32...+1112°F
									G 0...+800°C / +32...+1472°F
									H 0...+1000°C / +32...+1832°F
									K 0...+1200°C / +32...+2192°F
									Z Customized
									Certificates
									0 Without
									Accessories / phys. characteristics
									0 Without
									1 Head-mounted transmitter assembled to DIN-rail clip, 35mm
									2 Assembly kit for in-head mounting (spring-load)
									F Transmitter mounted into a plastic-housing 82x80x55mm, 2x M16x1,5 / IP65
VTT1	4								Continued on next page

VTT1	4											Calibration certificate	
												0	Without
												2	2 points (0 and 100%)
												3	3 points (0, 50 and 100%)
												4	5 points (0, 25, 50, 75 and 100%)
												5	11 points (0, 10, ..., 100%)
												Z	Customized
												Manuals	
												0	Without
												1	German
												3	English
												4	French
												5	Spanish
												G	German / English
												Private label	
												0	KROHNE Standard Version
Complete order code													



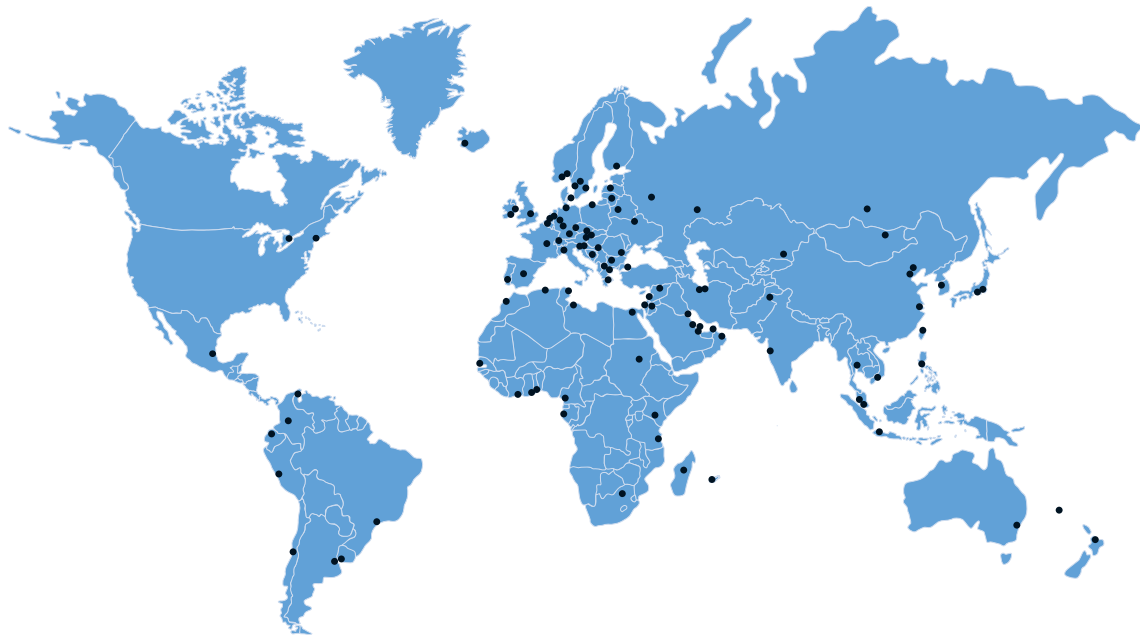

KROHNE product overview

- Electromagnetic flowmeters
- Variable area flowmeters
- Ultrasonic flowmeters
- Mass flowmeters
- Vortex flowmeters
- Flow controllers
- Level meters
- Temperature assemblies
- Pressure transmitters
- Analysis products
- Products and systems for the oil & gas industry
- Measuring systems for the marine industry

Head Office KROHNE Messtechnik GmbH
Ludwig-Krohne-Str. 5
47058 Duisburg (Germany)
Tel.: +49 203 301 0
Fax: +49 203 301 103 89
info@krohne.com

The current list of all KROHNE contacts and addresses can be found at:
www.krohne.com

KROHNE