

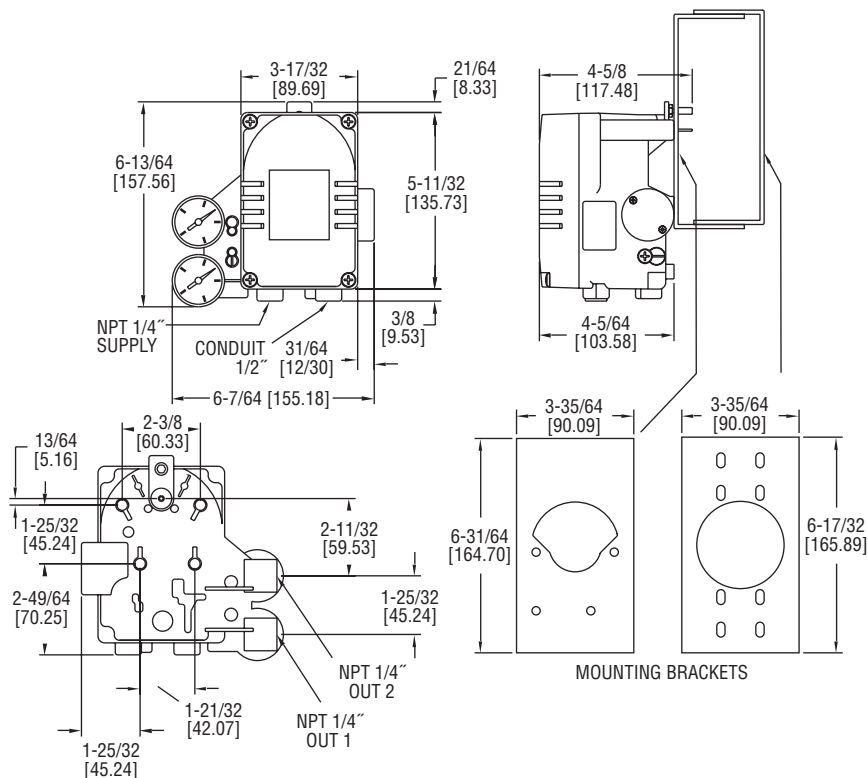

# Series 275 PRECISOR® III Electro-Pneumatic Positioner

## Specifications - Installation and Operating Instructions



**Series 275 PRECISOR® III Electro-Pneumatic Positioner** controls valve stroke accurately using an input signal of 4 to 20 mA from the controller. In addition, a highly efficient microprocessing operator built into the product. Performs various powerful functions such as Auto calibration, PID control, Alarm and Hart® protocol.

### FEATURES

- LCD allows user to directly check the positioner condition in the field.
- Endures severe vibration.
- Operates normally regardless of changes in supply pressure during operation.
- Simple to use auto calibration.
- Easily equipped on small actuators because of its small size.
- Low air consumption reduces operating cost.
- Can be used in low voltage (8.5V), leaving no limitation in controller.
- Variable orifice is applied in case of a small actuator, the hunting is controlled to the optimum condition during operation.
- HART® communication available for configuring parameters or monitoring the valve position.
- Analog feedback signal (4 to 20 mA).
- The adjustment of valve characteristics available.
- Specific flow control is available with setting 16 points at users' command.
- Tight Shut-Close and Shut-Open can be set in the programming menu.
- PID parameters can easily be adjusted in the field without additional communicator.
- Split ranges such as 4-12 mA, 12-20 mA are available.
- The positioner can manually actuate the valve or damper.

### SPECIFICATIONS

- Input Signal:** 4-20 mA DC.
- Input Impedance:** 460 Ohm max @ 20 mA DC.
- Material:** Aluminum diecasting.
- Air Supply:** 20 to 100 psi (1.4 to 6.9 bar).
- Air Connection:** 1/4" NPT.
- Gage Connection:** 1/8" NPT.
- Conduit Connection:** 1/2" NPT.
- Linearity:** ±0.5% of full scale.
- Hysteresis:** ±0.5% of full scale.
- Sensitivity:** ±0.2% of full scale.
- Repeatability:** ±0.3% of full scale.
- Air Consumption:** below 0.07 scfm (2 LPM) at 20 psig (1.4 bar) supply.
- Flow Capacity:** 2.5 scfm (70 LPM) at 20 psig (1.4 bar) supply.
- Stroke:** 0 to 90°.
- Enclosure Rating:** IP66.
- Ambient Temperature:** Operating: -22 to 185°F (-30 to 85°C).
- Weight:** 3.3 lb (1.5 kg).
- Lever:** 175: 0.39 to 1.57" (10 to 40 mm); 275: NAMUR.

HART® is a registered trademark of Hart Communication Foundation

**Series 275 Installation**

Series 275 is designed for rotary motion valves such as Dwyer Instruments ball and butterfly valves using rack and pinion, scotch yoke or complex type actuators whose stem is rotated 90°. Series 275 positioners consist of the following components:

1. Series 275 main body
2. Fork lever and lever spring to attach on actuator
3. 1 bracket
4. Four hex bolts M8x1.25P
5. Four M8 plate washers

**Series 275 installation example**

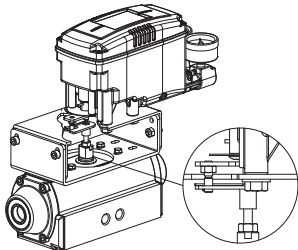

**Series 275 installation example of fork lever**

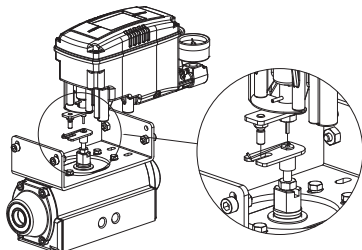

**Series 275 installation example of Namur shaft**

**Installing Series 275 with bracket**

Series 275 is supplied with a standard bracket. The bracket consists of two parts and is used with a NAMUR shaft. The bracket is assembled in the factory based on 0.79" (20 mm) of actuator stem height. If the actuator stem height is higher, such as 1.18" (30 mm), or 1.97" (50 mm), reassemble the bracket adjusting to the actuator stem height. Refer to the table below to check hole positions.

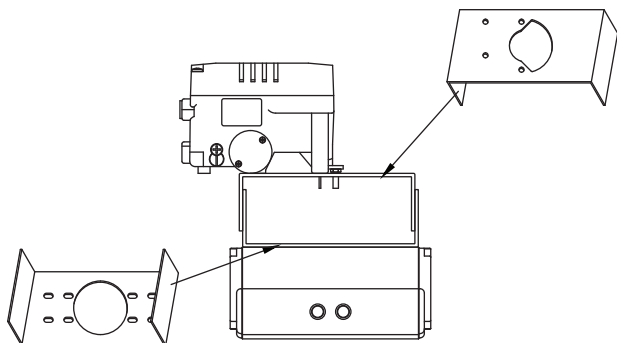

**Bracket assembly method by actuator stem height H**

Actuator stem height (H)	Markings of bolt holes			
	A-L	B-L	A-R	B-R
20 mm	H: 20	H: 20, 30	H: 20	H: 20, 30
30 mm	H: 30	H: 20, 30	H: 30	H: 20, 30
50 mm	H: 50	H: 50	H: 50	H: 50

Ex) If H is 30 mm, A-L should be locked in H:30 hole, B-L in H:20,30, A-R in H:30, and B-R in H:20,30 with bolts.

1. Typical actuator stem heights (H) are 0.79, 1.18 and 1.97 inches (20, 30, and 50 mm). After checking H, assemble brackets following previous guidelines. The bracket is set at 0.79" (20 mm) in the factory.

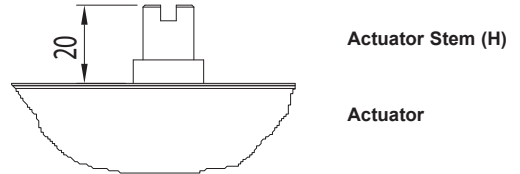

2. Attach bracket to the actuator using hex bolts. The diameter of the bracket bolt holes are 0.24" (6 mm). Use spring washers or thread lock compound so the bolts will not be loosened by vibration or impact. The direction of the bracket varies by operating conditions, but the normal direction is depicted in the following picture. That is, when the piping of actuator and Series 275 is as shown in direction A, the bracket hole and indicator attached on the bottom of the Series 275 main shaft should be mounted in the same direction.

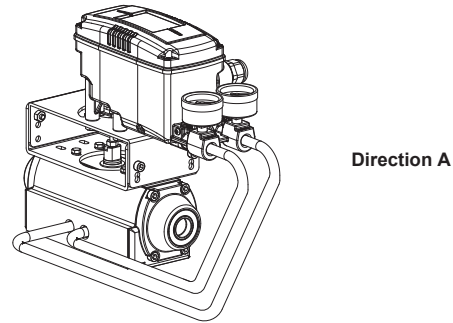

**Attachment direction of bracket and actuator**

3. Set the rotation position of actuator stem as the initial zero point, which is 0% stroke. For a spring return type actuator, the actuator stem is always rotated to the zero point without supply pressure, making it easy to check the zero point. If the actuator is double-acting, check whether the rotation direction of the actuator is clockwise or counter-clockwise or check the rotation direction of the actuator using supply pressure.
4. Set the actuator stem as the initial zero point and install a fork lever as shown in the following picture. Confirm the position of initial zero point when actuator stem is turned clockwise and counter-clockwise. Installation angle of fork lever should be about 45 degrees based on the linear shaft. But the angle is not related to NAMUR shaft.

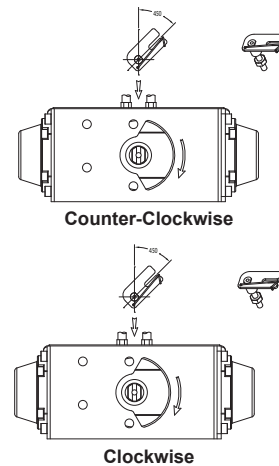

- Once the fork lever position is set, lock the check nuts on the bottom of the fork lever by turning clockwise. Set the upper height of the fork lever to 0.24 to 0.43" (6 to 11 mm) lower than the upper height of the bracket.

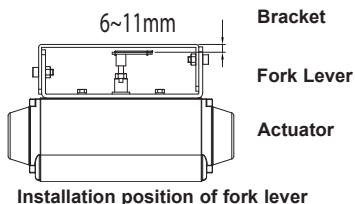

Installation position of fork lever

- Attach Series 275 unit to the bracket. Fix the clamping pin on the main shaft center of the Series 275 into the hole of the fork lever. Insert the connection bar attached on the main shaft lever into the fork lever slot to be locked by the fork lever spring. This is to fit the main shaft of the Series 275 to the center of the actuator stem. If they are not fitted correctly, too much force on the main shaft will greatly reduce product durability.
- Attach Series 275 base and the bracket with hex bolts and plate washers. It is best to lock the bracket and Series 275 together by inserting four bolts after checking the position.

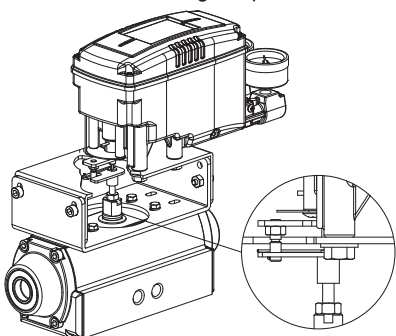

Fitting the pin on the Series 275 main shaft into fork lever hole

**PIPING CONNECTION**

**Note:**

- To prevent ingress of moisture, oil and dust, give careful consideration to the choice of supply pressure compressor and piping.
- It is recommended to attach filter or air filter regulator in front of the supply port of the Series 275 unit.

**Conditions of Supply Pressure**

- Dry air with a dew point that is at least 50°F (10°C) lower than that of the ambient temperature.
- Free from solid particles. Result of being passed through 5 micron or finer filter.
- Does not contain oil or lubricating oil.
- Comply with ANSI/ISA-57.3 1975(R1981) or ISA S7.3-1975(R1981).
- Not used beyond the range of 20 to 100 psi (140 to 689 kPa).
- Set supply pressure of air filter regulator to 10% higher than operating pressure of actuator.

**Conditions of Pipe**

- Remove foreign objects from inside of pipe.
- Do not use squeezed or broken pipe.
- To maintain flow rate of Series 275, use a pipe with inner diameter greater than 0.24" (6 mm) (outer diameter 0.39" (10 mm)).

**Piping Connection With Actuator**

Series 275 can operate as either single or double acting actuators.

**Single Acting Actuator**

To operate a single acting actuator, connect OUT1 port to actuator supply pressure port. Close off the OUT2 port with the supplied 1/4" NPT plug.

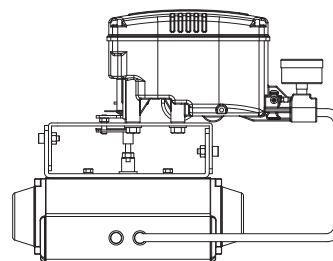

Piping connection example of Series 275 with single acting actuator

**Double Acting Actuator**

For the Series 275 double acting type, OUT1 and OUT2 ports are used.

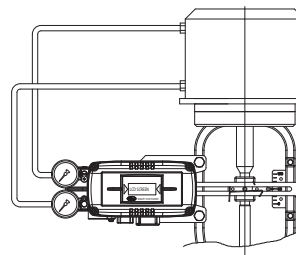

Piping connection example of Series 275 with double acting actuator

**Power Connection**

**Note:**

- Before connecting terminal, power must be shut off.
- Use ring type terminal against oscillation, impact, etc.
- Series 275 positioners use 4 to 20 mA DC for power. Minimum supply current is 3.2 mA (standard type) and 3.8 mA (HART® type). Maximum supply current must not exceed 24 mA.
- In order to protect the Smart Positioner, the ground terminals should be grounded.
- Use twisted cable with conductor sectional area at least 0.0019 in<sup>2</sup> (1.25 mm<sup>2</sup>), and suitable for 600V as on conductor table of NEC Article 310. Outer diameter of cable should be 0.25 to 0.39" (6.35 to 10 mm). Use shielded wire against electromagnetic waves and noise.
- Do not install the cable near equipment such as a high-capacity transformer or motor.

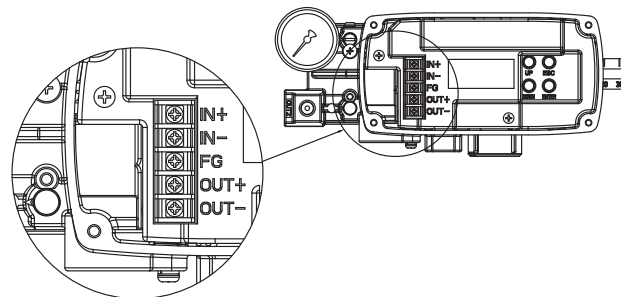

Terminal plate

**Terminal Connection of Current Input Signal**

1. Open cover by loosening the four screws on positioner cover.

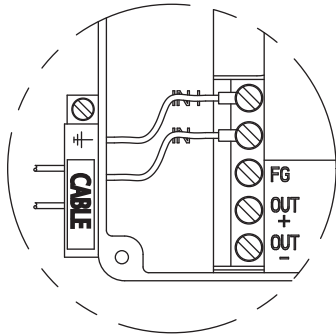

**Terminal connection of input current signal**

2. Loosen locking bolts of terminal plate.
3. Insert a cable through the cable connector in the positioner.
4. Use a ring type cable terminal so that it does not come out.
5. Insert terminal bolts in terminal holes of cable and lock them with (+) terminal and (-) terminals on the terminal plate. Tighten terminal bolts with 1.1 lbs-ft (15 kfgcm) torque.
6. Be sure not to change the polarity of terminals.

**Terminal Connection of Feedback Signal**

1. Open cover by loosening the four screws on the positioner cover.
2. Loosen terminal locking bolts of feedback signal terminals.

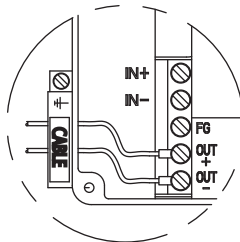

**Terminal connection of transmitter**

3. Insert a cable through the cable connector in the positioner.
4. Use a ring type cable terminal so it does not come out.
5. Insert terminal bolts in terminal holes of cable and lock them with (+) terminal and (-) terminals on the terminal plate. Tighten terminal bolts with 1.1 lbs-ft (15 kfgcm) torque.
6. Be sure not to change polarity of terminals.

**Inner Terminal Connection for Ground**

1. The ground is necessary for the safety of the positioner and system.
2. The ground terminals are inside the terminal in the center of the terminal plate and outside terminal beside outer cable entry. Use any ground terminal that is available. Resistance must be less than 100 Ohm.

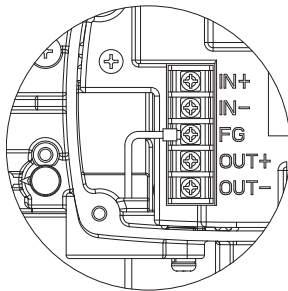

**Ground terminal connection**

3. For use with inside ground, open cover by loosening the four screws of positioner cover.
4. In order to maintain the ground connection, use a ring type ground cable terminal to prevent it from coming out.

**A/M Switch (Auto/Manual switch)**

The A/M switch is located on the bottom of the Series 275 positioners.

When set to auto, supply pressure is transmitted to actuator by the operation of the positioner. When set to manual, supply pressure of air filter regulator is transmitted to actuator regardless of positioner.

\* When A/M switch is set to manual, make sure that supply pressure range is not exceeded.

1. Make sure supply pressure is within range.
2. Turn switch clockwise and supply pressure of air filter regulator is transmitted to actuator.
3. Turn switch counter-clockwise to operate positioner manually.

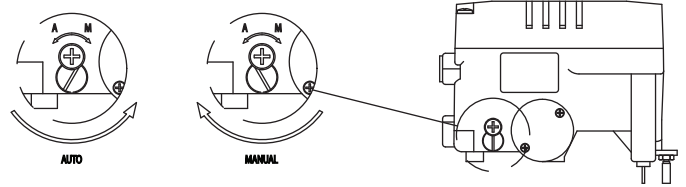

**Variable Orifice**

Hunting can occur if the actuator volume is too small. In this case, adjust the variable orifice using a (-) flathead screwdriver. Hunting is prevented by reducing the flow rate of supply pressure transmitted to actuator.

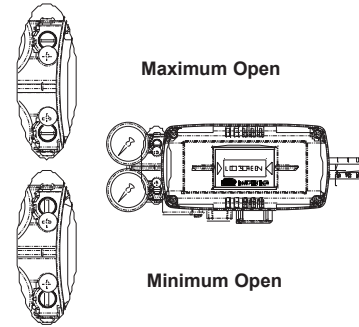

**Auto Calibration and Basic Operations**

Warning: Since this makes the valve or actuator move, before auto calibration, the valve must be separated from entire system.

**Buttons Operations**

Series 275 positioners perform various functions using four buttons. The position of the buttons is shown below:

Button	Function
<ENTER>	Enter to main menu and sub-menus, save adjusted parameter values, etc.
<ESC>	Return to previous menu
<UP> & <DOWN>	Move to next menu, change parameter values, etc.

**RUN Mode**

After connecting power to the positioner, the following is displayed on the LCD in 6 seconds.



RUN on the bottom line means that the Smart Positioner adjusts valve stroke based on an outside signal (4-20 mA) and PV refers to the number on the LCD. In RUN mode, valve stroke is changed according to input signal.

1	Run PV	Process Value	Valve Stroke (%)
2	Run SV %	Set Value	Input Signal (0 - 100%)
3	Run SV mA	Set Value	Input Signal (4 - 20 mA)
4	Run MV	Manipulate Value	Motor/Piezo Valve Manipulate Valve (Digit)
5	Run Vel	Velocity	Current Valve Stem's Velocity (Digit)
6	Run Err	Error	Difference between SV and PV (%)

There are six options in RUN mode. In order to change RUN display modes, hold <ESC> and press <UP> or <DOWN> to scroll through display options.

**First Auto Calibration**

First auto calibration is usually used when the positioner has not been set, such as the initial setting with valve at the valve company or replacement with other product in the field.

**Notice:** When the positioner is installed on the valve in the field after setting, we recommend using AUTO1 calibration rather than AUTO2 calibration. This is because the AUTO 2 calibration parameters have been factory set to the optimum settings.

	Zero Point	End Point	KP, KI, KD	RA/DA
AUTO1	°	°	x	x
AUTO2	°	°	°	°
AUTO3	x	x	°	°

**KP**

This is a proportion constant value that is correction by error %. If this value is too big, there can be hunting, even though it finds position by the input signal. If the value is too small, accuracy gets worse.

**KI**

This is an integral constant value adding or subtracting the correction that is corrected error % on the previous correction signal. If this value is too big, there can be oscillation. If it is too small, the time to find the exact position increases.

**KD**

This is a differential constant value adding the previous correction signal with the changing correction signal by the error % change rate.

**RA/DA**

Direct acting (DA) or Reverse acting (RA).

**Auto Calibration Types**

**Auto 1 Calibration (AUTO1)**

In this mode, all parameters necessary for valve operation are set except KP, KI, KD. It is used to re-execute calibration by users in the field after being supplied the positioner unit whose parameters were set by the valve company.

1. Push <ENTER> for 6 seconds in RUN mode and AUTO CAL message should appear.
2. Push <ENTER> and then AUTO1 mode is displayed.
3. Push <ENTER> again at AUTO1 mode and Auto 1 calibration is started.
4. When Auto 1 calibration is done, 'COMPLETE' message appears on the LCD. After 4 seconds the procedure returns to RUN mode and the valve stroke by current input signal is displayed as a percentage.

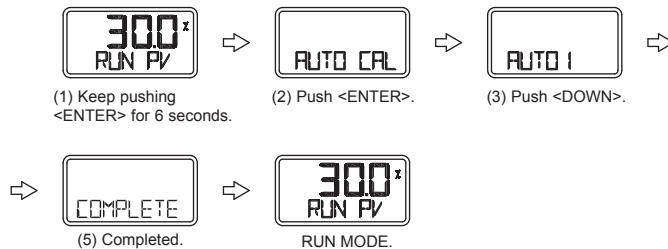

**Auto 2 Calibration (AUTO2)**

All parameters necessary to operate valve are set. This calibration is used when the positioner is first installed with valve. Refer back to First Auto Calibration.

**Auto 3 Calibration (AUTO3)**

All parameters necessary to operate valve are set except zero and end point. This function is used to re-execute auto calibration without changing the zero and end point after adjusting them manually.

1. Push <DOWN> at AUTO2 and AUTO3 is displayed.
2. Push <ENTER> and AUTO3 calibration is started. The remaining procedures of this calibration are the same as other calibrations.

**BIAS Calibration**

BIAS is the standard value of motor control in the positioner. It is affected by supply pressure, KP and other values. BIAS should be re-adjusted if supply pressure or KP is changed, otherwise accuracy will decrease.

1. Press and hold <ENTER> for 6 seconds in RUN mode and AUTO CAL message should appear.
2. Scroll with <DOWN> button until BIAS mode is displayed.
3. Push <ENTER> and BIAS calibration is started.
4. When BIAS calibration is done, 'COMPLETE' message appears on the LCD. After 4 seconds the procedure is returned to RUN mode.

**Velocity Calibration (V\_0)**

This function is used to find the standard value to recognize accurate valve speed. This value must be correct for KI control to work properly. To check if velocity value is correct:

1. Push <ESC> button at RUN mode and RUN Vel is displayed.
2. Check the number on the bottom of the screen. Normally, the value will be between -2 and 2.
3. If value is greater than 5, V\_0 calibration is required.

To calibrate V\_0:

1. Press and hold <ENTER> for 6 seconds in RUN mode until AUTO CAL message is displayed.
2. Scroll with <DOWN> button until V\_0 mode is displayed.
3. Push <ENTER> and calibration is started.
4. When V\_0 calibration is done, 'COMPLETE' message appears on the LCD. After 4 seconds the procedure is returned to RUN mode.

**Manual Mode**

Manual mode is used to raise or lower the valve stem manually. In this mode, the valve stroke is adjusted only by operating buttons, not by the current input signal. This mode does not affect controlling data registered in the positioner. It only is used to move the valve stem up and down.

1. Push <ENTER> at RUN mode until AUTO CAL message is displayed.
2. Push <DOWN> and MANUAL mode is displayed.
3. Push <ENTER> again. Two lines appear on LCD. The upper line indicates valve stroke by percentage and the lower line indicates absolute value of inner resistance of the positioner. \*MA means that Manual mode is in operation.
4. Push <UP> or <DOWN> and valve stem moves up or down. Regardless of RA/DA, if <UP> is pushed, valve stem moves up (in case of linear valve). If <DOWN> is pushed, valve stem moves down.

In order to make the valve stem move fast, push <ENTER> with <UP>, or <DOWN>.

Push <UP>.	Valve stem moves up slowly.
Push <UP> + <ENTER> at the same time.	Valve stem moves up quickly.
Push <DOWN>.	Valve stem moves down slowly.
Push <DOWN> + <ENTER> at the same time.	Valve stem moves down quickly.

**Button operation for valve stem movement**

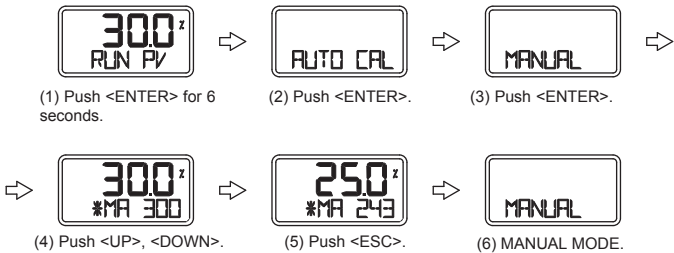

5. Push <ESC> and MANUAL mode is displayed.

**Parameter Mode (PARAM)**

**Parameter types**

There are four types in Parameter mode: Dead Zone, KP, KI, and KD.

These values are reflected as soon as they are changed, therefore the appropriate values are found by checking the valve's motion in real time.

**Dead Zone (dEAdZONE)**

This is the range of error % that the positioner is not adjusted. Hunting or oscillation due to friction between the stem and packing is prevented by this parameter.

**KP**

This is a proportion constant value that is correcting by error %. If this value is too big, there can be hunting, even though it finds position by the input signal. If the value is too small, accuracy gets worse.

**KI**

This is an integral constant value adding or subtracting the correction that is corrected error % on the previous correction signal. If this value is too big, there can be oscillation. If it is too small, the time to find the exact position increases.

**KD**

This is a differential constant value adding the previous correction signal with the changing correction signal by the error % change rate.

**Adjustment of Parameter**

**Dead Zone (dEAdZONE)**

1. Push <ENTER> at RUN mode for 6 seconds and AUTO CAL message appears.
2. Push <DOWN> twice and PARAM mode is displayed.
3. Push <ENTER> and dEAdZONE mode is displayed.
4. Push <ENTER> again and \*dEAdZONE message appears.
5. Adjust dEAdZONE value by pushing <UP> or <DOWN>. Adjusted value is applied immediately without additional operation. Users can easily check its adjustment by changing the current input signal to the positioner. Optimum control value is found by adjusting values during valve operation.
6. Push <ENTER> to save the value. +EAdZONE message appears on LCD.

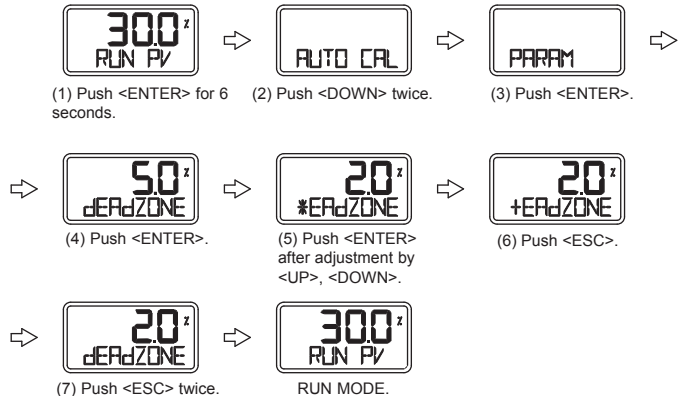

7. Push <ESC> three times to return to RUN mode.

**KP**

- 1-3. Adjustment method and procedure same as dEAdZONE.
4. Push <DOWN> at dEAdZONE mode and KP mode is displayed.
5. Push <ENTER> and \*KP message appears on LCD.
6. Adjust KP values with <UP> or <DOWN>. Adjusted value is applied immediately without additional operation. Users can easily check its adjustment by changing the current input signal to the positioner. Optimum control value is found by adjusting values during valve operation.
7. Push <ENTER> to save the value. +KP message appears on LCD.
8. Push <ESC>.

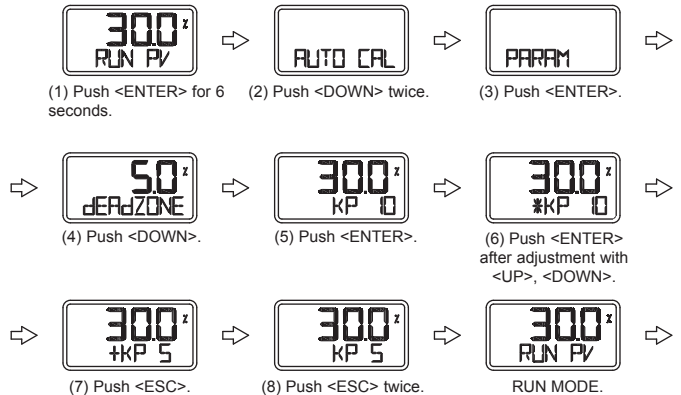

9. Push <ESC> twice to return to RUN mode.

**KI**

- 1-3. Adjustment method and procedure same as dEAdZONE.
4. Push <DOWN> twice at dEAdZONE mode and KI mode is displayed.
5. Push <ENTER> at KI mode and \*KI message appears on LCD.
6. Adjust KI value with <UP> or <DOWN>. Adjusted value is applied immediately without additional operation. Users can easily check its adjustment by changing the current input signal to the positioner. Optimum control value is found by adjusting values during valve operation. Push <ENTER> to save the value and +KI message appears on LCD.
7. Push <ESC>.

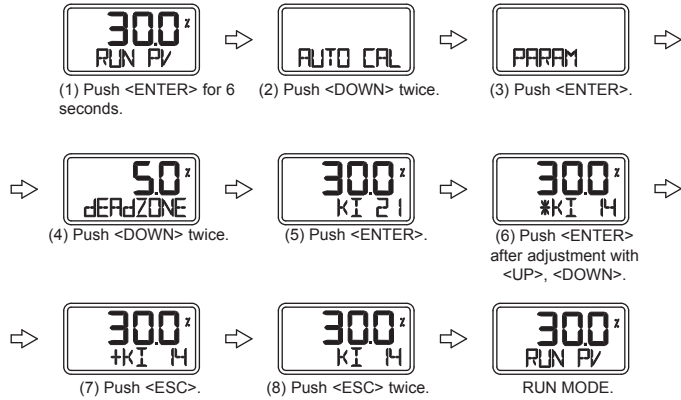

8. Push <ESC> twice to return to RUN mode.

**Kd**

- 1-3. Adjustment method and procedure same as dEAdZONE.
4. Push <DOWN> three times at dEAdZONE mode and Kd mode is displayed.
5. Push <ENTER> at Kd mode and \*Kd message appears on LCD.
6. Adjust Kd value with <UP> or <DOWN>. Adjusted value is applied immediately without additional operation. Users can easily check its adjustment by changing the current input signal to the positioner. Optimum control value is found by adjusting values during valve operation. Push <ENTER> to save the value and +Kd message appears on LCD.
7. Push <ESC>.

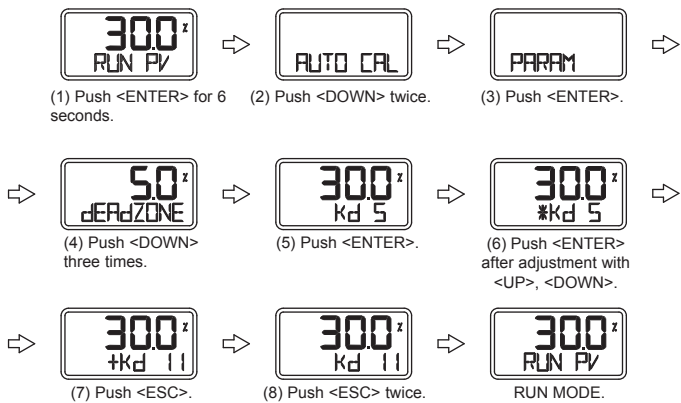

8. Push <ESC> twice to return to RUN mode.

**HAND CAL**

When auto calibration is started, Series 275 positioner set zero points and end points based on full stroke.

**Hand Calibration Types**

- PV\_ZERO: Edit mode to change the zero point of valve.
- PV\_END : Edit mode to change the end point of valve.
- TR\_ZERO : Edit mode to change the zero point of transmitter.
- TR\_END: Edit mode to change the end point of transmitter.

Adjustment of valve zero point (1 to 5) and end point (6 to 10).

1. Push <ENTER> at RUN mode for 6 seconds and then AUTO CAL mode is displayed. Push <DOWN> three times, the HAND CAL mode is displayed.
2. Push <ENTER> at HAND CAL mode and PV\_ZERO mode is started.
3. Push <ENTER> at PV\_ZERO mode and \*PZ mode is started. In this mode it is available to change valve zero point, and the valve stem moves automatically to the current zero point. On LCD, valve stroke is displayed as 0%. +PZ message that indicates edit mode of zero point and inner value showing current zero point position is also displayed.
4. Adjust valve stem by pushing <UP> or <DOWN>. When valve stem has arrived at the desirable zero point, save it with <ENTER>. +PZ message appears on LCD.
5. Push <ESC> to return to PV\_ZERO mode. (Push <ESC> twice to return to RUN mode.)
6. In order to change valve end point, push <DOWN> at PV\_ZERO mode and PV\_END mode begins.
7. Push <ENTER> at PV\_END mode and \*PE mode is displayed. At this mode it is available to change valve end point, and the valve stem moves automatically to current end point. On LCD, the valve stroke is displayed as 100%. \*PE message indicating edit mode of end point and inner value of end point is also displayed.
8. Adjust valve stem with using <UP> or <DOWN>. When valve stem arrives at the desirable end point, save it with <ENTER>. +PE message appears on LCD.
9. Push <ESC> to return to PV\_END mode.
10. Push <ESC> twice and RUN mode is displayed. (Push <DOWN> at PV\_END mode to go to TR\_ZERO mode).

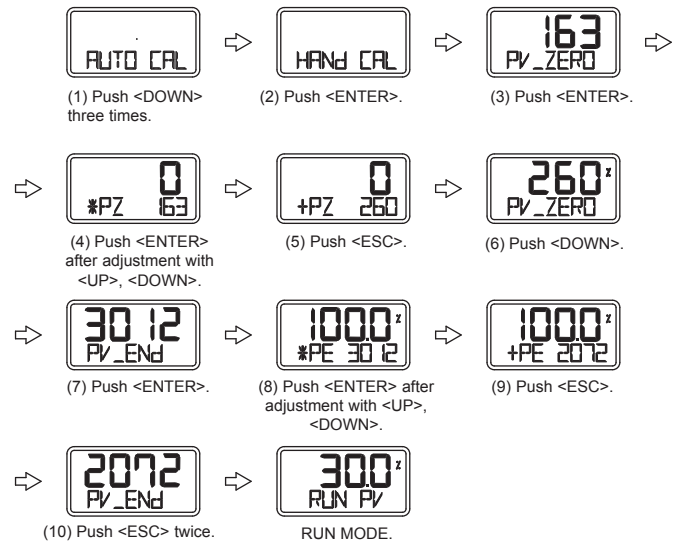

Adjustment of zero point (1 to 4), end point (5 to 9) of transmitter.

If valve zero point and end point are changed, transmitter is also changed automatically. Usually there is no need for the transmitter zero point and end point to be adjusted by users, but if transmitter output signal is unstable, transmitter zero point and end point should be adjusted. The ammeter showing feedback signal is necessary and the connection should be done as shown.

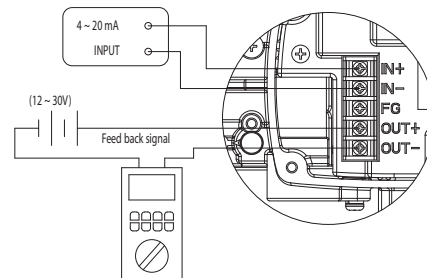

1. Push <DOWN> at PV\_END mode and then TR\_ZERO mode is displayed.
2. Push <ENTER>. \*R\_ZERO mode is started and at this mode users can adjust the zero point of the transmitter. Valve stem is moved to zero point automatically.
3. Push <UP> or <DOWN>. The number on the LCD is changed and the measured current value is changed accordingly on an ammeter equipped outside. Adjust it to be 4mA and push <ENTER> to save it. +R\_ZERO message is displayed.
4. Push <ESC>. TR\_ZERO mode is displayed.
5. Push <DOWN> at TR\_ZERO mode. Then TR\_END mode is displayed.  
(Push <ESC> twice to return to RUN Mode.)
6. Push <ENTER>. \*TR\_END mode is started and at this mode users can adjust the end point of transmitter. Valve stem is moved to the end point automatically.
7. Adjust measured current value to be 20 mA on ammeter with <UP> or <DOWN> buttons. Push <ENTER> to save it. +R\_END message appears.
8. Push <ESC>. TR\_END mode is displayed.

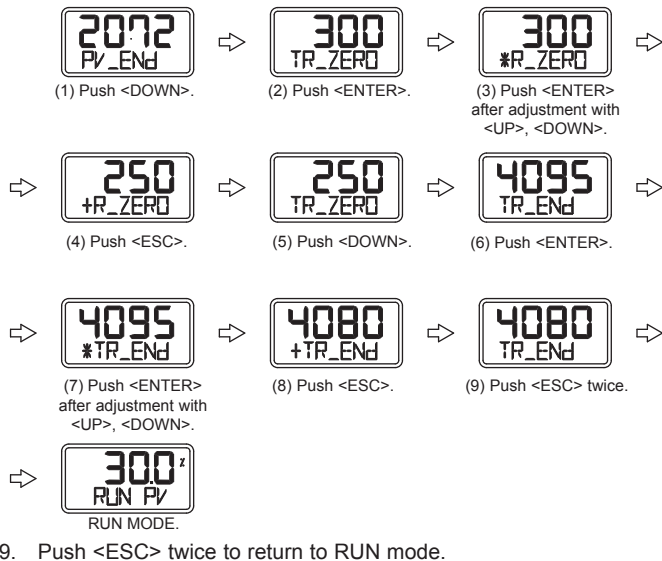

9. Push <ESC> twice to return to RUN mode.

**Valve Mode**

This mode adjusts the various characteristics.

**Action Type (ACT)**

It can be set to Direct Action (DA) or Reverse Action (RA).

**Characteristics (CHAR)**

It is set Characteristics. There are three types of valve characteristics: Linear (LIN), EQ% (EQ), and Quick Open (QO). The following is the example of the three characteristic curves.

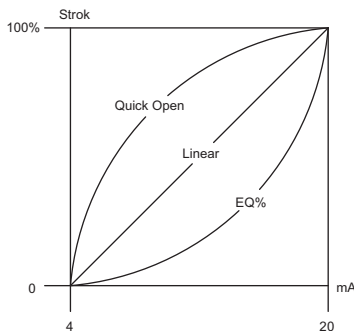

**User Characteristics (USER SET)**

When a specific characteristic is needed but not included in the above characteristics, the user can make a specific characteristic curve by choosing 16 points voluntarily according to field conditions and the user's need.

**Tight Shut Open (TSHUT OP)**

This allows the user to fully open valve at any value around the 20 mA current input signal.

**Tight Shut Close (TSHUT CL)**

This allows the user to completely close valve at value around 4 mA input signal from outside.

**Split Range Control (SPLIT)**

This allows the user to control entire stroke with input signals of 4 to 20 mA, 4 to 12 mA or 12 to 20 mA.

**Adjustment of Acting Type (ACT)**

1. Push <ENTER> at RUN mode for six seconds and then AUTO CAL mode is displayed. Push <DOWN> four times to go into VALVE mode.
2. Push <ENTER> and ACT RA (in case of RA) is displayed.
3. Push <ENTER> again, then \*ACT RA is displayed.
4. Adjust to \*ACT DA by pushing <UP> or <DOWN> and save it with <ENTER>. +ACT DA message appears.

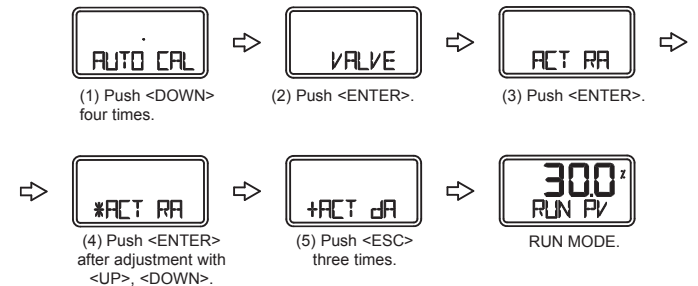

5. Push <ESC> three times to return to RUN mode.

**Adjustment of Characteristics (CHAR)**

1. Push <ENTER> at VALVE mode and then push <DOWN>. CHAR LIN (in case of linear characteristics) mode is displayed.
2. Push <ENTER>. \*HAR LIN mode is displayed and characteristics can be adjusted at this mode.

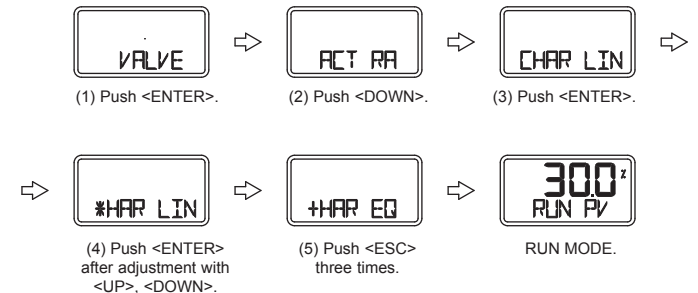

3. Adjust Characteristics (ex: EQ) by pushing <UP> or <DOWN> and save it with <ENTER>. +HAR EQ is displayed.
4. Push <ESC> three times to return to RUN mode.



**Adjustment of User Characteristics (USER SET)**

1. Push <ENTER> at VALVE mode and ACT RA or ACT DA is displayed.
2. Push <DOWN> twice, then USER SET mode is started.
3. Push <ENTER>. \*P0 SET mode is displayed. In this mode, users can adjust the first point of characteristic in 16 points. The number on the LCD is the valve stroke percentage set to P0.
4. Adjust valve stroke percentage using <UP> or <DOWN>.
5. Save it with <ENTER>. While P0 value is being saved, \*P1 SET mode is displayed.
6. \*P1 SET mode is used to adjust the second point of characteristic in 16 points. Adjustment method is the same as \*P0 SET mode.
7. Save the valve stroke percentage from P2 to P15 in the same way.
8. After adjustment of valve stroke percentage at \*P15 SET mode, save it with <ENTER>.
9. +SER SET is displayed. Sixteen points of valve stroke percentage are all set. Push <ESC> three times to return to RUN mode.

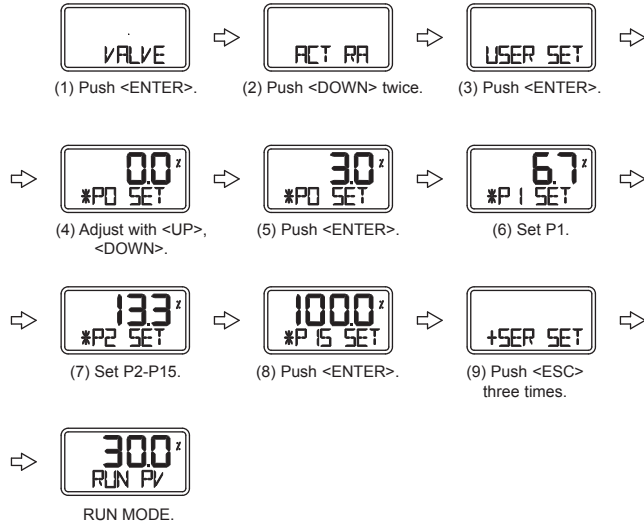

**Adjustment of Tight Shut Open (TSHUT OP)**

1. Push <ENTER> at VALVE mode and ACT RA or ACT DA is displayed. Push <DOWN> three times at this mode. TSHUT OP is displayed.
2. Push <ENTER>. \*SHUT OP mode is displayed and in this mode users can set stroke at the time of Tight Open. Initial setting is done as 100%, which means cancellation of this function. Adjust the value (ex: 95.0%) by pushing <UP> or <DOWN> and save it with <ENTER>. +SHUT OP is displayed.
3. Push <ESC> three times to return to RUN mode.

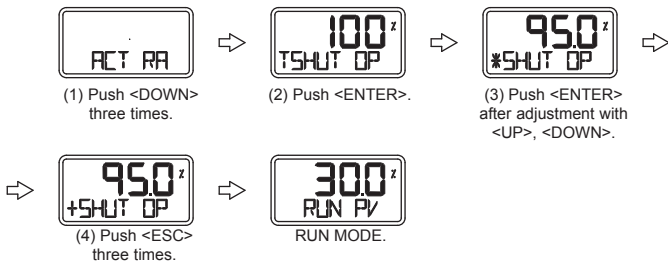

**Adjustment of Tight Shut Close (TSHUT CL)**

1. Push <ENTER> at VALVE mode and ACT RA or ACT DA is displayed. Push <DOWN> four times at this mode. TSHUT CL is displayed.
2. Push <ENTER>. \*SHUT CL mode is displayed and in this mode users can set stroke at the time of Tight Close. Initial setting is done as 0.3%. 0% means cancellation of this function. Adjust the value (ex: 0.5%) by pushing <UP> or <DOWN> and save it by pushing <ENTER>. +SHUT CL is displayed.

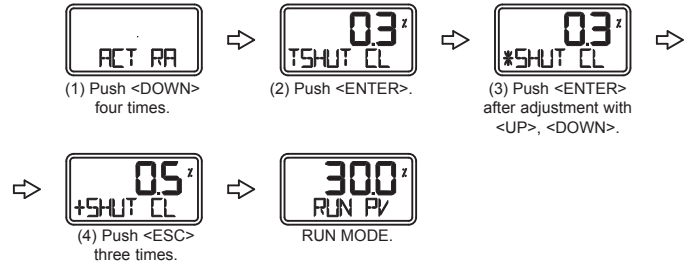

3. Push <ESC> three times to return to RUN mode.

**Adjustment of Split Range (SPLIT)**

1. Push <ENTER> at VALVE mode and ACT RA or ACT DA is displayed.
2. Push <DOWN> five times and SPLIT mode is displayed. The numbers on the LCD are the range of current signal input to the positioner. 4 to 20 mA current signal is set as the standard.
3. Push <ENTER>. \*SPLIT mode is displayed and input signal range can be adjusted. Adjust input signal range with <UP> or <DOWN> and save it with <ENTER>.
4. +SPLIT mode is displayed while saving adjusted range. Push <ESC> three times to return to RUN mode.

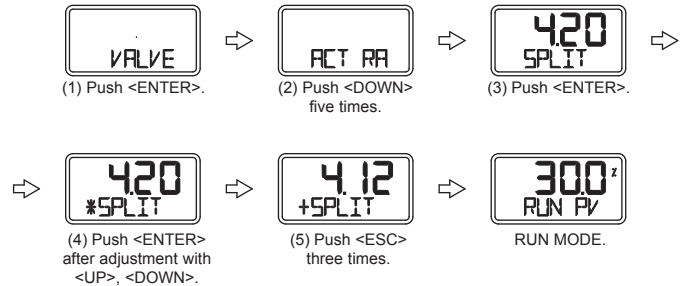

**VIEW Mode**

This mode provides users with various information about the Series v275 positioners. In this mode, users can change the valve stroke types displayed on LCD to % or numbers. Refer to the next table for information and description displayed on VIEW mode.

1. Push <DOWN> at AUTO CAL mode and VIEW mode is displayed.
2. Push <ENTER> at VIEW mode, then information mode is started.

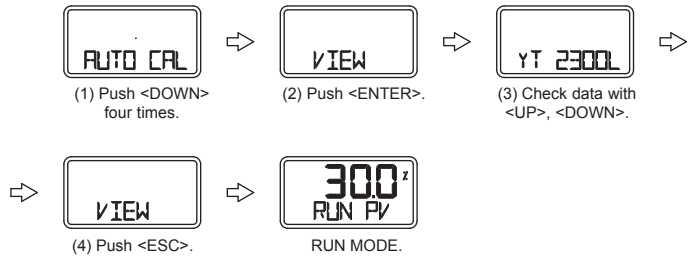

3. Check information by using <UP> or <DOWN> and push <ESC>.
4. Push <ESC> again to return to RUN mode.

Options	Description
VERSION	Main software version
HART V	HART® protocol version
POL Addr	Channel address used in HART® protocol
BIAS VI	BIAS value necessary to motor control (This variable is used only by manufacturer)
OY Od	Total using time But if the product is used less than one minute from power-on to power-off, it is not added to total time
FULL_OP	Full Open Time (sec) of valve
FULL_CL	Full Close Time (sec) of valve
VM NOR	Display type of valve stroke on LCD Either % or number is available
Erro	Error or warning code currently occurred. Refer to the Code table.
VALUE 1	Currently controlled I value (This variable is used only by manufacturer)

Information checked on VIEW mode

**Error and Warning Code**

If there are any problems during the Series 275 positioner operation, you can check the error and warning code at VIEW mode as follows:

**Error Code**

This code is displayed when the Series 275 positioner control becomes impossible. Code C, D applies.

**Warning Code**

This code is displayed when the positioner control is available but there is a possibility of malfunction or low accuracy. Code B, F, G, H applies.

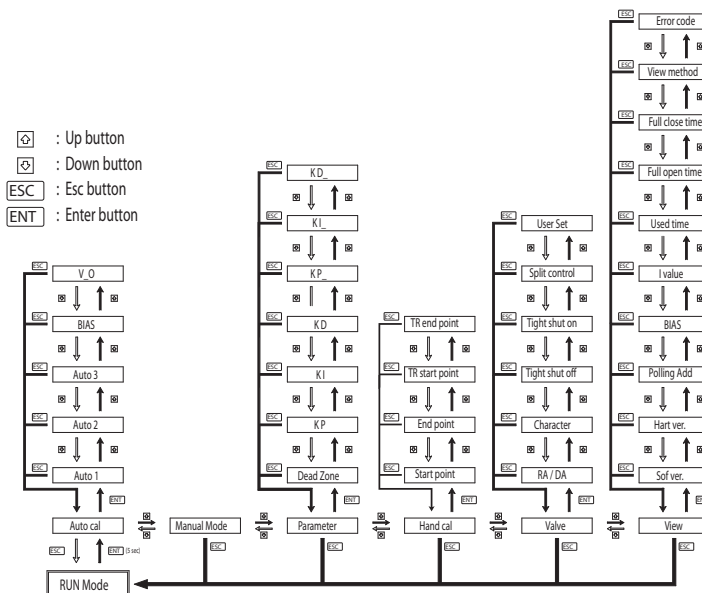

Code	Description and Cause	Measures
A	None	None
B	The range of Pv Span – Pv Zero is less than 500. Operating angle of feedback is too small.	-Increase operating angle of feedback lever and execute AUTO1 calibration.
C	More than 10% error is continued over more than one minute. -There's no valve movement. -Valve friction is getting too big. -Setting pressure of regulator is changed.	-Check the pressure setting of air filter regulator. Adjust it to recommended pressure Execute BIAS calibration
D	I value is at I max or min limit. -Valve friction has changed. -Setting pressure of regulator has changed.	-Check the pressure setting of air filter regulator. Adjust it to recommended pressure Execute BIAS calibration
E	None	None
F	Full Open, Close time is less than one second. -Actuator size is too small.	-Use variable orifice. -Replace actuator to bigger one.
G	Pv is set lower than 100. -Operating angle of feedback lever is set too big.	-Adjust operating angle of feedback lever to be smaller and execute AUTO1 calibration.
H	Pv is greater than 4000. -Operating angle of feedback lever is set too big.	-Adjust operating angle of feedback lever to be smaller and execute AUTO1 calibration.

Error/Warning code

**MAINTENANCE**

The Series 275 PRECISOR® III Positioner is not field serviceable and should be returned if repair is needed (field repair should not be attempted and may void warranty). Be sure to include a brief description of the problem plus any relevant application notes. Contact customer service to receive a return goods authorization number before shipping.