

Features

- Non-rising stem design.
- female end connections.
- Orifice : 16.5mm
- Cracking Pressure Range : 15 ~ 2400 psig
- Valve are supplied with protective painted surface. (Only standard for carbon steels.)

Technical Data

Working Pressure	Cracking Pressure	Orifice	Orifice Area
4,000psig (275bar)	15 ~ 2400 psig	0.65in. (16.5 mm)	0.311 in ² (201 mm ²)

Materials of Construction

Component	Valve Materials	
	Carbon Steel	Stainless steel
1. Body	ASTM A216 Gr.WCB	ASTM A351 CF3M
2. Frame O-Ring	FKM	FKM
3. Seat Frame	ASTM A105	ASTM A276 TYPE 316
4. Cap	CABON STEEL	ASTM A276 TYPE 316
5. Jam Nut	CABON STEEL	ASTM A276 TYPE 316
6. Disc Rod	ASTM A276 TYPE 316	ASTM A276 TYPE 316
7. Disc	ASTM A276 TYPE 316	ASTM A276 TYPE 316
8. Bolt	ASTM A276 TYPE 316	ASTM A276 TYPE 316
9. Insert Holder	ASTM A276 TYPE 316	ASTM A276 TYPE 316
10. Seat	PTFE	PTFE
11. Seat O-ring	FKM	FKM
12. Seat Guide	ASTM A276 TYPE 316	ASTM A276 TYPE 316
13. Holder O-Ring	FKM	FKM
14. Keeper Guide	ASTM A276 TYPE 316	ASTM A276 TYPE 316
15. Bushing	CABON STEEL	ASTM A276 TYPE 316
16. Bushing O-Ring	FKM	FKM
17. Spring Keeper	ASTM A276 TYPE 316	ASTM A276 TYPE 316
18. Adjust O-Ring	FKM	FKM
19. Adjust Screw	ASTM A276 TYPE 316	ASTM A276 TYPE 316
20. Spring	AISI 1086 OR EQUIVALENT	AISI 1086 OR EQUIVALENT
21. Spring Guide	ASTM A276 TYPE 316	STAINLESS STEEL 316

* Wetted parts and lubricants listed in blue.

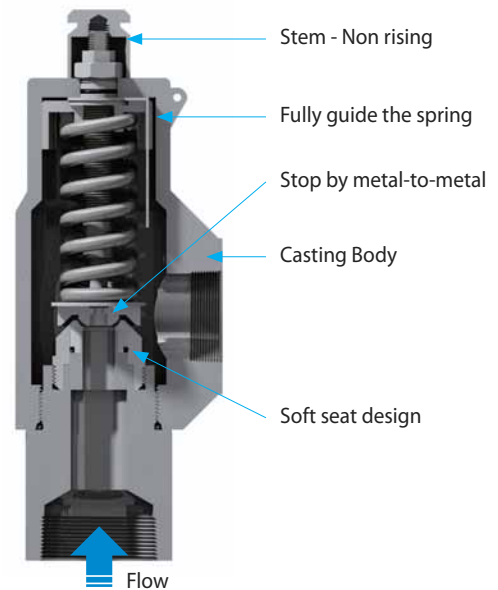

Operation

When the inlet pressure overcomes the set spring pressure, it causes the valve to open, releasing flow to bypass and thereby balance the system pressure.

Factory Test

Every valve is factory tested for cracking and reseal performance.

IDK-LOK® Sampling Cooler

Ordering Number and Dimensions

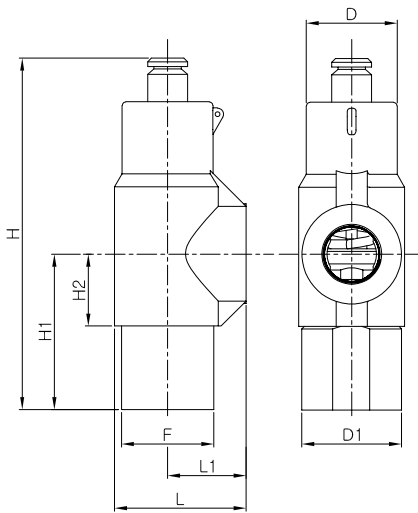

Flow Rate

Media	AIR	Gas	Water
SG	1	0.6	0.6
Temp.	60°F	60°F	60°F
Factor Kd	0.818	0.818	0.818
Set pressure (psig)	SCFM	SCFM	SCFM
15	165	206	38
20	191	238	43
25	216	269	48
30	241	301	52
50	352	439	67
75	491	613	82
100	630	786	95
125	769	959	106
150	908	1133	116
200	1186	1480	134
300	1742	2173	164
400	2298	2866	190
500	2854	3560	212
600	3409	4253	233
700	3965	4947	251
800	4521	5640	269
900	5077	6333	285
1000	5633	7027	300
1100	6189	7720	315
1250	7022	8760	336
1500	8412	10494	368
2000	11191	13961	425
2400	13415	16735	465

Basic Ordering Number and Dimensions

Ordering Number	End Connection		Dimensions, in. (mm)								
	Inlet	Outlet	H	H1	H2	L	L1	D	D1	Orifice	
V64-	F2N-S	1/8 in. Female NPT	1-1/2 in. Female NPT	11.1 (282)	4.9 (124.6)	2.27 (57.6)	4.15 (105.5)	2.48 (63)	2.48 (63)	3.15 (80)	0.65 (16.5)
	F24N	1-1/2 in. Female NPT									
	F32N24N	2 in. Female NPT	1-1/2 in. Female NPT								
	MF32N	2 in. Male NPT	2 in. Female NPT								
	F32N	2 in. Female NPT									

All dimensions shown are for reference only and are subject to change.

Ordering Information

Select the desired valve basic ordering number in the table 4, applicable O-Ring designator, Spring designator, and Valve body material in the table below.

O-Ring Material Designators	Spring Set Pressure Designators Unit: psig	Sour gas service	Example of a complete ordering Number.
Nil : Standard FKM O-Ring HBN : HNBR EP : EPDM	1 : 15-40 2 : 41 - 100 3 : 101 - 215 4 : 216 - 350 5 : 351 - 750 6 : 751 - 1000 7 : 1001 - 1800 8 : 1801 - 2400	C : Carbon Steel S : Carbon Steel	V64-F12N16N-EP-8-C Factory Set Valve To order, specify the set pressure on the valve ordering number. i.e., V64-F-8N16N-1100-C

Safe Valve Selection

The selection of a valve for any application or system design must be considered to ensure safe performance. Valve function, valve rating, material compatibility, proper installation, operation and maintenance remain the sole responsibility of the system designer and the user. DL-Lok accepts no liability for any improper selection, installation, operation or maintenance.

IDK-LOK®
Fittings & Valves
www.dklok.com

IDK-LOK Corporation
Mailing Address
7, Golden root-ro 129beon-gil, Juchon-myeon,
Gimhae-si, Gyeongsangnam-do, South Korea 621-842

DK-Lok contact information
Tel. (82) 55-338-0114
Fax. (82) 55-901-0143
E-mail : sales@dklok.com

For International customers
Tel. (82) 55-338-0031/2
Fax. (82) 55-901-0142
E-mail : dklok@dklok.com