



## Installation Instructions

# CL Series *Chain Wheels*

### Models:

**CL6, CL7.5, CL9, CL12, CL15, CL18, CL21, CL24 and CL30**

### Parts:

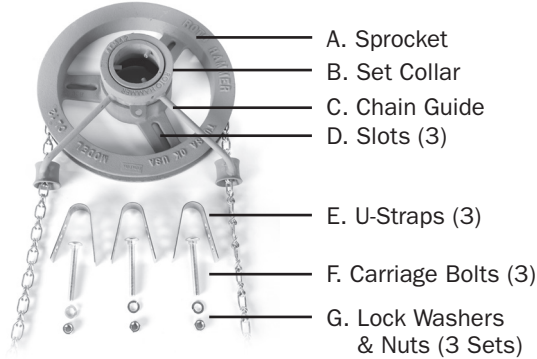

### Completed Assembly:

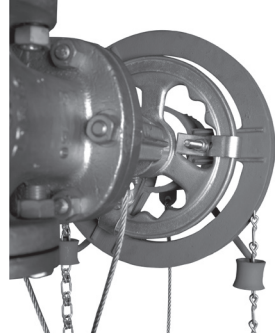

### Procedure:

- ① Place U-Strap (E) over rim of valve handwheel. Open side of U-Strap should face the center of the chain wheel.
- ② Place Sprocket (A) against front of handwheel. Align one Slot (D) with holes in U-Strap and inset Bolt (F) through both the slot and holes in the strap.
- ③ Attach Lock Washer & Nut (G) and hand tighten.
- ④ Repeat procedures 1, 2 and 3 on each of the two remaining straps.
- ⑤ Center the Sprocket and tighten all nuts securely.

### Caution:

To prevent the handwheel from backing off the stem, the Handwheel Retaining Nut **MUST** be secured with a Set Screw. In addition, it is strongly recommended that an appropriately sized Roto Hammer RCK Safety Cable Kit (optional) be installed on every overhead chain wheel operated valve. All chain wheel installations should be properly maintained and regularly inspected. Set screws and other threaded fasteners **MUST** be secure and tight.

See other side for Instructions for CL4